

الجمهورية الجزائرية الديمقراطية الشعبية

PEOPLE'S DEMOCRATIC REPUBLIC OF ALGERIA

وزارة التعليم العالي والبحث العلمي

Ministry of Higher Education and Scientific Research

University 20 August 1955 -

Skikda

Faculty of Technology

Department of Civil

Engineering



جامعة 20 أوت 1955 سكيكدة

كلية التكنولوجيا

قسم الهندسة المدنية

Thesis submitted to obtaining the diploma of  
**Master degree in Civil Engineering**  
**Option: Structures**

**Calculation of a reinforced concrete building of G+5 for  
residential use**

Presented by : **Bouguern rima**

**Defended publicly in : 26/06/2024**

### **Board of Examiners**

<b>President</b>	<b>Pr BOUZIANE Salah</b>		University of Skikda
<b>Supervisor</b>	<b>Pr DJEBIEN Rachid</b>	<b>MCA</b>	University of Skikda
<b>Examiner</b>	<b>PrBOUZRED Hmoudi</b>		University of Skikda

**Promotion2023/2024**

# Thanks

Above all, we would like to thank Almighty God for giving us strength and courage to complete this work.

We extend our most sincere thanks to our supervisor, **Mr Djebien Rachid** for his support and his availability, and for directing us throughout this work.

We warmly thank our respective families for all the help and moral support, that they gave us throughout our studies. We hope to live up to their hopes and show ourselves worthy of their trust and encouragement.

Our thanks also go to the members of the jury for agreeing to examine our project.

I thank those whose names do not appear on this page and who helped us in some way or another.

# DEDECACE

It is with the help and grace of GOD that we complete this humble work.

Dedicates this modest work to our parents for their great love, support and sacrifice unwavering.

To our dear friend Aya Grirem for her great help and constant support towards us

To our friends: Nardjess; mohamed; islem ; frah ; aya ; and to all those who are close to our hearts and who encourage and support us to give the best of ourselves.

*Bouaouina nourhane & Bouguern Rima*

# Contents

- I.1 Introduction :** ..... 1
- I.2 presentation of the work:** ..... 1
- I.2.1 Geometric characteristics:** ..... 1
- I.2.2 Site category:** ..... 1
- Table I.2: Site data**
- I.3 the elements of the work:** ..... 1
  - I.2.1 Carrier system:** ..... 1
  - I.2.2 Floor:** ..... 2
  - I.2.3 stairs :** ..... 2
  - I.2.4 The Balconies:** ..... 2
  - I.2.5 Masonry :** ..... 2
  - I.2.6 The Coverings:** ..... 2
  - I.2.7 Acroterium:** ..... 3
  - I.2.8 The Terrace:** ..... 3
  - I.2.9 The Infrastructure:** ..... 3
- I.4 Security And Regulations :** ..... 3
  - I.4.1 Algerian Seismic Regulations (Rpa99 Version 2003):** ..... 3
  - I.4.2 Regulatory Technical Document (D.T.R. - B.C. 2.2) “Permanent Loads And Operating Expenses”:** ..... 4
  - I.4.3 General Information On The C.B.A 93 (The Bael 91 Rules):** ..... 4
    - I.4.3.1 Ultimate Limit States (ELU):** ..... 4
    - I.4.3.2 Calculation Assumptions At ELU (C.B.A 93 A.4.3.2):** ..... 4
    - I.4.3.3 Service Limit States (ELS) :** ..... 4
    - I.4.3.4 ELS Calculation Assumptions (C.B.A. Regulation 93 A.4.5.1):** ..... 4
    - I.4.3.5 Rule Of The Three Pivots:** ..... 4
- I.5 Action And Requests :** ..... 5
  - I.5.1 Action (Regulation C.B.A 93 A.3.1):** ..... 5
  - I.5.2 permanent Actions G:** ..... 5
  - I.5.3 Qi Variable Action:** ..... 5
  - I.5.4 Fa Accidental Actions:** ..... 5
  - I.5.5 Solicitations (Regulation C.B.A 93 A.3.2):** ..... 6
  - I.5.6 Requests For Calculation Of Combinations Of Actions (Regulation C.B.A 93 A.3.3):** ..... 6
  - I.5.7 Calculation Requests With Respect To The Ultimate Resistance Limit States:..... 7**

<b>I.5.8 Fundamental Combination (C.B.A. Regulation 93 A.3.3.2.1):</b>	7
<b>I.5.9 Accidental Combination (C.B.A. Regulation 93 A.3.3.2.2):</b>	7
<b>I.5.10 Calculation Requests With Respect To The Ultimate Service Limit States (C.B.A 93 A.3.3.3):</b>	8
<b>I.5.11 Verification Of Static Balance (C.B.A 93 A.3.3.4):</b>	8
<b>1.5.12 Verification Of Shape Stability (C.B.A 93 A.3.3.5 And A.4.4):</b>	8
<b>I.5.11 Material Characteristics:</b>	8
<b>I.5.12 Concrete (CBA .93 (A.2.1)):</b>	8
<b>I.5.12.1 Definition:</b>	8
<b>I.5.12.2 Concrete Dosage:</b>	8
<b>I.5.12.3 Mechanical Resistance Of Concrete:</b>	9
<b>I.5.12.4 Characteristic Resistance To Compression (C.B.A 93 A.2.1.1.1):</b>	9
<b>I.5.12.5 Tensile Strength Of Concrete (BAEL A.2.1.12):</b>	9
<b>I.5.12.6 Longitudinal deformation modulus (C.B.A 93. A.2.1.2):</b>	9
<b>I.5.12.7 Poisson's Ratio (C.B.A 93. A.2.1.3):</b>	10
<b>1.5.12.8 Other Properties of Concrete:</b>	10
<b>I.5.13 Steels:</b>	12
<b>a) Definition</b>	12
<b>I.5.13.1 Different Types Of Steel:</b>	12
<b>I.5.13.2 RI Smooth Rounds:</b>	12
<b>I.5.13.3 High Adhesion Steels:</b>	12
<b>I.5.13.4 Welded Mesh:</b>	13
<b>I.5.13.5 Mechanical Characteristics:</b>	13
<b>I.5.13.6 Limit Stress Of Steels:</b>	13
<b>I.8.2.8 Ultimate Limit State :</b>	13
<b>I.5.13.9 Service Limit State:</b>	14
<b>1.9 Conclusion:</b>	15
<b>II.1. The objective of pre-dimensioning :</b>	17
<b>II.2. Pre-dimensioning of elements:</b>	17
<b>II.2.1. The beams:</b>	17
<b>II.2.1.1. The main beams :</b>	17
<b>II.2.1.2. The secondary beams :</b>	18
<b>II.2.2. the column :</b>	19
<b>II.2.3. Floors:</b>	20
<b>II.2.4. Joists :</b>	20

<b>II.2.5. The parapet :</b> .....	21
<b>II.2.6. Balcony :</b> .....	22
<b>II.2.7. The Sails :</b> .....	22
<b>II.2.8. The stairs :</b> .....	23
<b>II.2.9. Platform Beam :</b> .....	25
<b>□.3. Evaluation of the applied loads :</b> .....	27
<b>II.3.1. Inaccessible terrace floor :</b> .....	27
<b>II.3.2. current slab plan for residential use :</b> .....	27
<b>II.3.3. Exterior Walls :</b> .....	28
<b>II.3.4. Interior walls :</b> .....	29
<b>II.3.5. Balcony :</b> .....	29
<b>II.3.6. The Sails :</b> .....	30
<b>II.4. Load descent :</b> .....	30
<b>II.4.1. Introduction :</b> .....	30
<b>II.4.2. Center column :</b> .....	30
<b>II.5. Degression of loads :</b> .....	32
<b>II.5.1. Introduction :</b> .....	32
<b>II.5.2. Center column load degression:</b> .....	32
<b>III.1 Introduction:</b> .....	36
<b>III.2 Study Of The Parapet :</b> .....	36
<b>III.2.1 Intoduction :</b> .....	36
<b>III.2.2. Checking the parapet for earthquakes:</b> .....	37
<b>III.2.3 Requests:</b> .....	38
<b>III.2.3.1 combination of actions :</b> .....	39
<b>III.2.4 Reinforcement calculation:</b> .....	40
<b>III.2.4.1 Determination of eccentricity at ULS(CBA93 A.4.3.5):</b> .....	40
<b>III.2.4.2 The Filling Coefficient :</b> .....	41
<b>III.2.4.3 Reinforcement section:</b> .....	42
<b>III.2.4.4 Condition of non-fragility (CBA93 Art A.4.2):</b> .....	44
<b>III.2.4.5 Distribution frame:</b> .....	44
<b>III.2.4.6 Verification of the shear force (CBA93 Art A.5.1):</b> .....	44
<b>III.2.5 Verification at the SLS:</b> .....	45
<b>III.2.5.1 Calculating the moment of inertia:</b> .....	46
<b>III.2.5.2 Calculation of constraints:</b> .....	46
<b>III.3. Floor study:</b> .....	47

III.3.1. Introduction:	47
III.3.2. The different types of floors:	47
III.3.3. The compression slab :	48
III.3.3.1 Types of beams :	50
III.3.3.2 Flat rate method:	51
III.3.3.3 Application of the method:	51
III.3.3.3 Caquot method (Appendix E.2 of BAEL91):	53
III.3.3.3.1 Assessment and combination of loads :	53
III.3.3.4 Evaluation of moments on supports :	54
III.3.3.5 Evaluation of moments in spans :	55
III.3.3.6 Evaluation of shear forces :	61
III.3.4.2 At support :	67
III.3.4.3 Non-fragility condition :	69
III.3.5 Transverse reinforcement:	69
III.3.6 Spacing of transverse reinforcements:	69
III.3.5 Verification at the SLS :	70
III.3.8 Verification of the shear force (CBA93 A.5.1):	72
III.3.9 Verification of the deflection (CBA93 B.6.8.4.2.4):	72
III.3.10 Reinforcement detailing :	73
□.4. The Balconies :	75
□.4.1. Definition :	75
□.4.2. Primaire slab case resting on two dimensions :	75
□.4.2.1 Method of calculation :	75
□.4.2.2. Combination of loads :	76
□.4.2.3. Determination of reinforcement :	76
□.5. Stairs:	81
□.5.1 Definition:	81
□.5.2. Evaluation of the loads :	81
□.5.3. Combinations of action :	82
□.5.4. Calculation of reinforcement :	83
□.5.5. Verification SLS :	84
□.5.6.Reinforcements distribution :	85
□.5.7Reinforcement Spacing :	85
□.5.8.Verification of shear force:	86
□.5.9. Stair reinforcement diagram :	86

□.6. Study of the platform screen beam :	90
□.6.1. Load evaluation :	90
□.6.2. Load on the landing beam :	91
□.6.3. Reinforcement Design at the Strength ULS :	91
□.6.3. Condition of non-fragility : BAEL 91 (art A.4.2.1) .....	92
2.5. Verification S.L.S :	92
□.6.4. Verification of shear force :	93
□.6.5. Calculates the torsional of the platform screen beam :	94
□.6.6. Reinforcement diagram of a platform screen beam :	95
<b>IV.1 Introduction :</b>	<b>98</b>
<b>IV.2.1 Modeling software :</b>	<b>98</b>
<b>IV.2.2 Modeled elements :</b>	<b>99</b>
<b>IV.2.3 Structure mesh:</b>	<b>99</b>
<b>IV.2.4 Modeling steps:</b>	<b>100</b>
<b>IV.3 Classification criteria by RPA 99 version 2003:</b>	<b>108</b>
<b>IV.3.1 Classification of seismic zones:</b>	<b>108</b>
<b>IV.3.2 Classification of structures according to their importance :( RPA 99 version 2003).....</b>	<b>109</b>
<b>IV.3.3 Site classification :</b>	<b>109</b>
<b>IV.3.4 Classification of bracing systems: (RPA99/Version2003 Art 3.4):</b>	<b>110</b>
<b>IV.3.5 Classification of the structure according to its configuration: (RPA99/Version2003 Art 3.5) .....</b>	<b>110</b>
<b>IV.4 Presentation of the different methods for estimating seismic forces :</b>	<b>113</b>
<b>IV.4.1 The equivalent static method : (RPA99/Version2003 Art 3.5).....</b>	<b>113</b>
<b>IV.4.2 Modal spectral dynamic method :(RPA99/Version2003 Art3.5).....</b>	<b>113</b>
<b>IV.4.3 The dynamic analysis method using accelerograms :</b>	<b>115</b>
<b>IV.5 Geometric and Mass Characteristics of the Structure :</b>	<b>115</b>
<b>IV.6 Structure Analysis :</b>	<b>118</b>
<b>IV.6.1 Principles of Arrangement of Bracing Elements (Walls) :</b>	<b>119</b>
<b>IV.6.2 Calculation response spectrum :</b>	<b>122</b>
<b>IV.6.3 Results and verifications of dynamic analysis :</b>	<b>127</b>
<b>IV.6.3.1 Verification of behavior for the first three modes :</b>	<b>128</b>
<b>IV.6.3.2 Verification of the specific mass participation :</b>	<b>130</b>
<b>IV.6.3.3 Verification of reduced compressive normal force (RPA99/Version2003 Art7.1.3.3) :</b>	<b>131</b>
<b>IV.6.3.4 Tangential solicitations (A.7.4.3.2 RPA99/2003) :</b>	<b>132</b>

IV.6.3.5	Verification of the resultant of seismic design forces :	133
IV.6.3.6	Distribution of the resultant seismic forces according to height:	138
IV.6.3.7	Verification of inter-floor displacements :	140
IV.6.3.8	Justification with respect to the P- $\Delta$ effect:	142
IV.7	Conclusion:	143
V.1.	Introduction :	145
V.2.	The combinations of actions :	145
V.3.	Reinforcement beams :	146
□.3.1.	Role of reinforced concrete beams :	146
□.3.2.	Recommendation :	146
V.4.	Reinforcement of the main beams :	147
□.4.1.	Longitudinal reinforcement :	148
□.4.2.	Verification required :	150
□.4.3.	Transverse reinforcement :	152
□.4.4.	Checking the Arrow :	153
V.5.	Reinforcement of secondary beams :	155
□.5.1.	Longitudinal reinforcement :	156
□.5.2.	Verification required :	158
□.5.3.	Transverse reinforcement :	160
□.5.4.	Checking the Arrow :	162
□.6.	Reinforcement of the columns:	163
□.6.	the columns :	164
□.6.1	Introduction :	164
□.6.2.	Roles of reinforced concrete columns :	164
□.6.3.	Solicitations to consider :	164
□.6.4.	Recommendations :	165
□.6.5.	reinforcement of columns :	169
□.6.6.	Verification required :	179
□.6.7.	Transverse reinforcement :	180
□.6.8.	Shear force verification :	181
□.6.9.	Buckling Verification :	182
□.6.10.	Diagram of the reinforcement of column :	183
□.7	Calculation of the sails :	184
□.7.1.	Principles of sails sizing :	185
□.7.2.	Recommendation of RPA99/2003 :	186

❖	Specification for Horizontal Steels (A.7.7.4.2 RPA99/2003) :	186
□.7.3.	Reinforcement of the sails :	187
□.7.4.	Example of Calculation :	189
□.7.5.	Diagram of the reinforcement of the sail :	196
	<b>Study of the Infrastructure</b> .....	198
<b>VI.1</b>	<b>Introduction :</b> .....	198
<b>VI.2</b>	<b>Different types of foundations :</b> .....	198
<b>VI.3</b>	<b>Calculation Combinations :</b> .....	199
<b>VI.4</b>	<b>Soil Investigation :</b> .....	199
<b>VI.5</b>	<b>Selection of Foundation Type :</b> .....	199
<b>VI.6</b>	<b>Calculation of the footing area :</b> .....	200
<b>VI.6.1</b>	<b>Verification of the isolated footing :</b> .....	200
<b>VI.7</b>	<b>Study of the raft foundation :</b> .....	201
<b>VI.7.1</b>	<b>Preliminary sizing of the raft slab :</b> .....	201
<b>VI.7.1.1</b>	<b>The lump sum condition:</b> .....	202
<b>VI.7.1.2</b>	<b>Shear strength condition:</b> .....	202
<b>VI.7.2</b>	<b>Preliminary Sizing of the Rib :</b> .....	203
<b>VI.7.2.1</b>	<b>Lump Sum Condition:</b> .....	203
<b>VI.7.2.1.1</b>	<b>Rib Height:</b> .....	203
<b>VI.7.2.1.2</b>	<b>Rib Width:</b> .....	203
<b>VI.7.2.2</b>	<b>Elastic Length Condition:</b> .....	203
<b>VI.7.3</b>	<b>Overflow Calculation :</b> .....	204
<b>VI.7.4</b>	<b>Punching shear verification (CBA93 A.5.2.4.2) :</b> .....	205
<b>VI.7.5</b>	<b>Verification of non-lifting (pressure effect) :</b> .....	206
<b>VI.7.6</b>	<b>Geometric characteristics of the raft :</b> .....	207
<b>VI.7.6.1</b>	<b>Center of gravity of the raft foundation masses :</b> .....	208
<b>VI.7.6.2</b>	<b>Center of gravity of the building masses (superstructure) :</b> .....	208
<b>VI.7.6.3</b>	<b>Determination of eccentricity :</b> .....	209
<b>VI.7.7</b>	<b>Determination of loads and surcharges :</b> .....	209
<b>VI.7.8</b>	<b>Check :</b> .....	210
<b>VI.7.9</b>	<b>Justification of foundation stability (A.5.7 RPA99/2003) :</b> .....	210
<b>VI.7.9.1</b>	<b>Verification of soil stress under vertical load :</b> .....	210
<b>VI.7.9.2</b>	<b>Verification of compression under <math>G+Q\pm E</math> :</b> .....	210
<b>VI.7.10</b>	<b>Reinforcement of the raft :</b> .....	212
<b>VI.7.10.1</b>	<b>Evaluation of loads :</b> .....	212

<b>VI.7.10.2 Calculation of requests :</b> .....	213
<b>VI.7.10.3 Calculation of reinforcements :</b> .....	214
<b>VI.7.10.4 Longitudinal reinforcement :</b> .....	216
<b>VI.7.10.6 Transverse reinforcement :</b> .....	217
<b>VI.7.10.7 Verification at the SLS :</b> .....	217
<b>VI.7.11 Study of overflow :</b> .....	219
<b>VI.7.11.4 Verification of the shear force :</b> .....	220
<b>□.8. Reinforcement of the ribs :</b> .....	222
<b>□.8.1. Rib loads :</b> .....	222
<b>□.8.2. Calculation of reinforcement :</b> .....	223
<b>□.8.3. Verification required :</b> .....	223
<b>□.8.4. Rib reinforcement diagram :</b> .....	227

## List of figure

Figure 1.1 : Compressive stress, deformation diagram at the ELS.....	1
Figure 1.2 : Compressive stress, deformation diagram at the ELU.....	2
Figure1.2 :Stress-deformation diagram (Steel) at the ELU.....	3
Figure II.1 : joist section.....	4
Figure II.2: Diagram of the parapet.....	5
Figure II.3: Elevation sail cutting.....	6
Figure II.4 : stair plan view.....	7
Figure II.5: shema of an inaccessible terrace slab.....	8
Figure II.6 : schema of a current floor slab.....	9
Figure II.7: Detail of the components of an exterior wall.....	10
Figure II.8 : Detail of the components of an interior wall.....	11
Figure III.1: Presentation of the static diagram of the parapet.....	12
Figure III.2 : Internal Forces Diagram.....	13
Figure III.3 : Reinforcement diagram of the parapet.....	14
Figure III.3 : Reinforcement diagram of the parapet.....	15
FigureIII.4 : Descriptive diagram of a hollow body floor.....	16
Figure II.5 : compression slab.....	17
Figure III.6 :Reinforcement of the compression slab.....	18
FigureIII.7 :Beams Type 01.....	19
FigureIII.8 :Beams Type 02.....	20
FigureIII.9 : Beams Type03.....	21
Figure III.10 : ULS moment diagram - beam Type 3 (current floor).....	22
FigureIII.11 : SLS moment diagram - beam Type 3 (current floor).....	23
FigureIII.14: ULS moment diagram - beam Type 2(current floor).....	24
Figure III.15 : SLS moment diagram - beam Type 2 (current floor).....	25
FigureIII.17:SLS moment diagram - beam Type1 (Terrce floor).....	26
Figure III.16: ULS moment diagram - beam Type 1 (Terrce floor).....	27
FigureIII.18: ULS moment diagram - beam Type 1 (current floor).....	28

Figure III.19: SLS moment diagram - beam Type 1 (current floor).....	29
Figure III.20 : Diagram of shear forces for type 3 beam (current floor).....	30
Figure III.21 : Diagram of shear forces for type 2 beam (current floor).....	31
Figure III.22 : Diagram of shear forces for type 1 beam (terrace floor).....	32
Figure III.23 : Diagram of shear forces for type 1 beam (Current floor).....	33
Figure III.25 : Reinforcement of beams on support (type 2).....	34
Figure III.24 : Reinforcement of beams on span (type 2).....	35
Figure III.26 : reinforcement of the beam.....	36
Figure III.27: Static diagram of the balcony.....	37
Figure III.28 : Shema of reinforcement in balconies.....	38
Figure III.29 : Schema bench.....	39
Figure III.30 : Reinforcement diagram of the stair cutting 1-1.....	40
Figure III.31 :Reinforcement diagram of the stair cutting 2-2.....	41
Figure III.32:Reinforcement diagram of a platform screen beam.....	42
Figure IV.1 : Modeling software.....	43
Figure IV.2 : Mesh options adopted for our.....	45
Figure IV.3 : Choice of structure type.....	46
Figure IV.4 : Case preferences.....	47
Figure IV.5 : 3D view of the structure.....	48
Figure IV.6 : Viewed in plan in each direction.....	49
Figure IV.7 : Theoretical eccentricity.....	50
Figure IV.8 : Number of Walls.....	51
Figure IV.9 : Spacing between bracing elements. (AFPS, 0220).....	52
Figure IV.10 : Redundancy and a broad base ensure better distribution.....	53
Figure IV.11 : Asymmetrical arrangement of shear walls should be avoided.....	54
Figure IV.12 : Arrangement of the bracing shear walls.....	55
Figure IV.13 : Flowchart for Justification of the R coefficient.....	56
Figure IV.14 : Flowchart of Normal Force Distribution.....	57
Figure IV.15 : Calculation response spectrum following X.....	58
Figure IV.16 : Calculation response spectrum following Y.....	59

Figure IV.17 : Behavior of the 1st mode.....	60
Figure IV.18 : Behavior of the 2nd mode.....	61
FigureIV.1 : Modeling software.....	62
FigureIV.2 : Mesh options adopted for our.....	63
Figure IV.3 : Choice of structure type.....	64
Figure IV.4 : Case preferences.....	65
FigureIV.1 : Modeling software.....	66
FigureIV.2 : Mesh options adopted for our.....	67
Figure IV.3 : Choice of structure type.....	68
Figure IV.4 : Case preferences.....	69
Figure V .7 : Moment diagrams flexing My to the ULS.....	70
Figure V .8 : Moment diagrams flexing My to the SLS.....	71
Figure V .9 : Moment diagrams flexing My to the ALS.....	72
Figure V .13: solicitation of a columns.....	73
Figure □.14: Flowchart justifying the State of stress of the sections subjected to compound bending.....	74
Figure □.15 : folwchart for calculating reinforcement section according the state of stress...75	75
Figure □.16 : Calculation cross section for columns.....	76
Figure □.17 :Diagram of the reinforcement of column.....	77
Figure □.18 : Behavior of the veil as a console.....	78
Figure □.19 : Lateral instability of the sails.....	79
Figure □.20 : Arrangement of vertical reinforcement in the walls.....	80
Figure □.21 : Stresses on the bracing sails.....	81
Figure□.22 : Constraints on the sails.....	82
Figure □.23 : Constrain diagram.....	83
Figure □.24 :Diagram of the reinforcement of the sail.....	84
Figure VI.1 Isolated footing.....	85
Figure VI.2 Raft surface.....	86
Figure VI.3 Reinforcement of the slab in x-x direction.....	87
Figure VI.4 Reinforcement of the slab in Y-Y direction.....	88
Figure □ : Rib loads in SLS.....	90

Figure 1 : Rib loads in ULS.....	91
Figure 2 : 8.4. Rib reinforcement diagram.....	92

## List of Tableue

Tableau I.1: Geometry of the structure.....	1
Table I.2: Site dataI.3 the elements of the work.....	2
Tab. 1.3: Values of the guaranteed elastic limit fe .....	3
Tableau 1 I.4Mechanical characteristics of the materials used.....	4
Table II.3.1 : dead loads returning to the inaccessible terrace slab.....	5
Table II.3.2 : dead loads due to the current level floor slab.....	6
Table II.3.3. Evaluation of exterior wall loads.....	7
Table II.3.4. Evaluation of interior wall loads.....	8
Table II.3.4 Evaluation of balcony loads.....	9
Table II.3.4. Evaluation of sail loads.....	10
Table II.4.1. Load descent of Center column.....	11
Tab.III.1 Floor stresses.....	12
Tab.III.2 Moment on terrace floor support Type 1 .....	13
Tab.III.3 Moment on current floor support Type 1 .....	14
Tab.III.4 Moment on current floor support Type 2.....	15
Tab.III.6 Moment on current floor support Type 3.....	16
Tab.III.7 Moment in span type 3 current floor.....	17
Tab.III.8 : Moment in span type 2 current floor.....	18
Tab.III.9 : Moment in span type 1 terrace floor.....	19
Tab.III.10 : Moment in span type 1 current floor.....	20
Tab III.11 : shear forces for current floor –beams type 02.....	21
Tab III.12: shear forces for terrce floor –beams type 01.....	22
III.13:shear forces for current floor –beams type 01.....	23
Tab III.14 : Maximum loads type 1 (terrace floor).....	24
Tab III.15 : Maximum loads type 1 (Current floor).....	25
Tab III.16 : Maximum loads type 2 (current floor).....	27
Tab III.17 :Maximum loads type 3 (current floor).....	28
Tab III.18 verification $M_{ut} \leq M_{tab}$ .....	29
Tab III.19: Calculate reinforcement for the span.....	30

Tab III.20 : Calculate reinforcement for the supports.....	31
Tab III.21 : Floor reinforcement.....	32
Tab III.22 : Checking the shear force.....	33
Table III .23: Evaluation of current floor balcony loads.....	34
Table □.24:Moments and shear force in the landing beam.....	35
Table IV.1. : Center of mass of each floor.....	36
Tab IV.2 : Torsional center of each floor.....	37
Tab IV.3 : Static and accidental eccentricity.....	38
Tab TV.4 : Restrained eccentricity.....	39
Tab IV.5. : Values of T1 and T2 (Table 4.7. RPA).....	40
Tab IV.6. Zone acceleration coefficient (Table 4.1. RPA).....	41
Tab IV.7 : The vertical loads supported by the bracing system.....	42
Tab IV.8 : Damping Value Table 4.2 RPA.....	43
Tab IV.9 : Quality factor.....	44
Figure IV.10 : Behavior of the first three modes.....	45
Tab IV.11 : Verification of mass participation.....	46
Tab IV.12 : Verification of the reduced normal force.....	47
Tab IV.13 : Verification of Tangential Stresses along X-axis.....	48
Tab IV.14 : Verification of Tangential Stresses along Y-axis.....	49
Tab IV.15 : Verification of the fundamental period.....	50
Tab IV.16 :Summary of results.....	51
Tab IV.17 : Distribution of the resultant of seismic forces.....	52
Tab IV.18 : Overturning moment in both X and Y directions.....	53
Tab IV.19 : Stability moment in both X and Y directions. ....	54
Tab IV.20 : Verification of overturning stability.....	55
Tab IV.21 : Inter-story displacement verification along the X direction.....	56
Tab IV.22 : Inter-story displacement verification along the Y direction.....	57
Tab IV.23 :Verification of displacements at the top following both directions.....	58
Tab IV.24 : Justification regarding the P- $\Delta$ effect according to X.....	59
Tab IV.25 : Justification regarding the P- $\Delta$ effect according to Y.....	60

Table IV.1. : Center of mass of each floor.....	61
Tab IV.2 : Torsional center of each floor.....	62
Tab IV.3 : Static and accidental eccentricity.....	63
Tab IV.4 : Restrained eccentricity.....	64
Tab IV.5. : Values of T1 and T2 (Table 4.7. RPA) .....	65
Tab IV.6. Zone acceleration coefficient (Table 4.1. RPA) .....	66
Tab IV.7 : The vertical loads supported by the bracing system.....	67
Tab IV.8 : Damping Value Table 4.2 RPA.....	68
Tab IV.9 : Quality factor.....	69
Figure IV.10 : Behavior of the first three modes.....	70
Tab IV.11 : Verification of mass participation.....	71
Tab IV.12 : Verification of the reduced normal force.....	72
Tab IV.13 : Verification of Tangential Stresses along X-axis.....	73
Tab IV.14 : Verification of Tangential Stresses along Y-axis.....	74
Tab IV.15 : Verification of the fundamental period. ....	75
Tab IV.16 :Summary of results.....	76
Tab IV.17 : Distribution of the resultant of seismic forces.....	77
Tab IV.18 : Overturning moment in both X and Y directions.....	78
Tab IV.19 : Stability moment in both X and Y directions.....	79
Tab IV.20 : Verification of overturning stability.....	80
Tab IV.21 : Inter-story displacement verification along the X direction.....	81
Tab IV.22 : Inter-story displacement verification along the Y direction.....	82
Tab IV.23 :Verification of displacements at the top following both directions.....	83
Tab IV.24 : Justification regarding the P- $\Delta$ effect according to X.....	84
Tab IV.25 : Justification regarding the P- $\Delta$ effect according to Y.....	85
Tab □.1 : Calculation data.....	86
Tab □.2 : Summary of the loads for the main beams.....	87
Tab□.3. Summary of loads for beams Secondary. ....	88
Tab□.4 : Design note for secondary beams in span.....	89
Tab□.5 : Design note for secondary beams in support.....	90

Tab □.6 : sollicitation of the column (35cm * 45cm).....	91
Tab □.7: Reinforcement of the columns.....	92
Tablue □.8 : Stresses of the sail.....	93
Tab □.9 : Calculation result.....	94
Tabl VI.1 Geometric characteristics of the raft.....	95
Tabl VI.2 Inertia and Center of Gravity of the raft foundation.....	96
Tabl VI.3 Reinforcement moments of the raft slab.....	97
Tab. VI.4: Verification at the SLS.....	98
Tab VI.5: The reinforcements at the SLS.....	99
Tab VI.6 Overflow characteristics.....	100
Tableau VI.1 : Summary of requests.....	101
Tablue VI : verification of the rib of the slab at the SLS in the X-X direction.....	102

## List of abbreviations and symbols

As area of section of steel

A: sum of the areas of the right sections of a course of transverse reinforcement

B: area of section of concrete

D: diameter, stiffness

E: longitudinal modulus of elasticity

E<sub>b</sub> concrete longitudinal deformation module.

E<sub>i</sub> : instantaneous deformation module (E<sub>vj</sub>: for the age of(j) days).

E<sub>s</sub>: elastic modulus of steel.

E<sub>v</sub>: deformation module differs (E<sub>vj</sub>: for loading applies at the age of j days).

F: force or general action.

G: dead loads

Q: live loads.

I : moment of inertia.

L: length or range.

M: bending moment usually.

M<sub>u</sub>: moment at the ultimate limit state.

M<sub>ser</sub> : computation time at service limit state.

N: normal loads.

Q : variable action or load.

S : section.

T , v :shear force.

W: Weight of the structure.

f<sub>cj</sub>: characteristic compressive strength of concrete j days old

f<sub>tj</sub> characteristic tensile strength of the old days j

f<sub>e28</sub> et f<sub>r28</sub>: previously calculated quantities a '28 days.

l: the distance between bare supports (direction of the main beams).

l': the distance between bare supports (direction of the secondary beams).

d : useful height.

h<sub>p</sub> : thickness of the slab.

h<sub>t</sub>: girder height.

h<sub>o</sub> : thickness of the compression slab.

L<sub>cc</sub>: the length of the hollow slab.

L<sub>x</sub>: Distance between two beams

L<sub>y</sub>: Distance between bare supports in the direction of disposition of the beams. If Buckling length

A': section of compression reinforcement

A : strain reinforcement section

A<sub>r</sub> : distribution reinforcing section.

e : Eccentricity of a result or an load in relation to the section center of gravity

l<sub>s</sub>: Sealing Length.

s: spacing of reinforcement in general.

St : spacing of transverse reinforcement.

$f_c$  : limit of elasticity of the steel

Sraft: Surface of the raft.

$\gamma_b$ : Concrete safety Coefficient.

$\gamma_s$ : steel Safety Coefficient.

$\alpha$  : Angle in general, coefficient

$\xi_{bc}$ : Relative shortening of concrete.

$\xi_s$ : Deformation of steel.

$\eta$ : factor of cracking relative to a reinforcement.

$\Theta$  : Coefficient without dimension

$\lambda$  : twinge  $\mu$ : Coefficient of friction.

$\mu$  : Poisson coefficient.

$\rho$ : reference of two dimensions; in particular reference of steel area to the concrete area...

$\sigma$ : General normal stress.

$\sigma_{bc}$ : Concrete compression stress.

$\sigma_s$ : Tensile stress in the steel.  $\sigma_{adm}$ : eligible stress.

$\tau_v$ : eligible tangential stress.

$\tau_s$ : Adhesion stress.

$\psi_s$ : Coefficient of sealing relative to a reinforcement.

$\zeta$ : Percentage of critical damping.

CT: Coefficient that depends on the bracing system

## **ABSTRACT**

This project presents a detailed study of a building for residential use, consisting of a ground floor plus (05) floors, which will be located in the wilaya of: SKIKDA This city is classified as an average seismicity zone (IIa ) according to RPA99 version 2003.

The resistance of the structure to horizontal and vertical stresses is ensured by a composite bracing system in reinforced concrete.

The dimensioning and the reinforcement of all the resistant elements were in conformity with the Algerian standards (CBA.93 and RPA99 version 2003).

The calculation of the various forces under the effect of static and dynamic stresses was carried out using the software (ROBOT Autodesk 2010). the infrastructure by calculating the foundations. Furthermore, the drawings was carried out by the software AUTO CAD 2013.

Key words :

Building, Reinforced concret

## ملخص

هذا المشروع يقدم دراسة مفصلة لإنجاز بناية سكنية وتجارية تتألف من طابق أرضي+(05) طوابق ببلدية سكيكدة المصنفة ضمن المنطقة الزلزالية (IIa) حسب المركز الوطني للبحث المطبق في هندسة مقاومة الزلزل.

مقاومة البناية محققة بواسطة نظام تدعيم مختلط ( جدران مسلحة + أعمدة وعوارض) .

الدراسة الديناميكية لهذه البناية تمت بواسطة برنامج Robot 2010

( وفي الاخير دراسة الأجزاء المقاومة للبناية (أعمدة، روافد...) اعتمد أساسا على القواعد المعمول بها في الجزائر وهي RPA99/Version2003 , BAEL 91

الكلمات المفتاحية: العمارة، الخرسانة المسلحة، تدعيم

مختلط ،

## **Résumé**

Ce projet est une étude détaillée d'un bâtiment en béton composé d'un rez-de-chaussée et de 5 étages supérieurs, qui a été construit dans la wilaya de Skikda, EL-MATCHE, qui est classée dans les zones moyen-nement sismiques selon le système sismique algérien.

En utilisant les règles de calcul et de vérification de l'Algérie (BAEL91, CBA93, RPA99/2003, DTR), nous avons calculé les dimensions et déterminé la quantité de ferrailage nécessaire à la stabilité du bâtiment. En plus du processus d'abaissement des charges appliquées au bâtiment. Nous avons également traité une étude sismique à l'aide d'un programme basé sur la méthode des éléments finis (ETABS 20). Les forces résultantes dans les différents éléments structuraux ont été calculées à l'aide de deux méthodes, dont l'une est la méthode du spectre de modèle d'appariement, et l'autre est la méthode d'analyse par le diagramme d'accélération réelle (séisme de Skikda 2020).

Cette étude nous a permis de déterminer les dimensions des éléments et la quantité de ferrailage nécessaire pour la stabilité et la tenue au séisme. Et aussi une comparaison rapide entre différentes méthodes d'analyse sismique.

Les mots clés :

Béton armé, ferrailage, spectre de réponse, analyse d'accélération, résistance, stabilité

# General Introduction

Building has always been one of the first concerns of human and one of his privileged occupations. To date Construction has enjoyed great growth in most countries and many professionals are engaged in construction activities in the building or public works sector.

A structure must be calculated and designed in such a way that it remains fit for the purpose for which it was intended, taking into account its intended life span and cost.

- ❖ It must not be damaged by events, such as: explosion, shock or other phenomena.
- ❖ It must resist all actions and other influences that may occur both during Execution and during operation and that it has a sustainable durability in terms of maintenance costs.

**Chapter I** : consists of the complete presentation of the building, the definition of the different elements and the choice of materials to be used.

**Chapter II** : presents the pre-dimensioning of structural elements (talque the columns, columns, beams and walls), and non-structural elements (such as floors, etc.).

**Chapter III** : calculation of the secondary elements (the parapet, the beams, the stairs) is the subject.

**Chapter IV** : will focus on the dynamic study of the building, the determination of the seismic action and the structure's own dynamic characteristics during its Vibration. The study of the building will be carried out by analysing the 3D model of the structure using the ROBOT calculation software.

**Chapter V** : Calculation of structural reinforcement based on the results of the ROBOT2010 software.

**Chapter VI**: Calculation and sizing of the infrastructure to determine the type of foundations.

# CHAPTER I

## PRESENTATION OF THE PROJECT

## Presentation of the project

### I.1 Introduction :

During the design of the project, the civil engineer takes care of the calculations and simulations. He is the one who chooses the materials to use and defines the working methods. To do this, it takes into account production costs and manufacturing times.

### I.2 presentation of the work:

The project that we chose, as part of our end-of-studies project, consists of a ground floor + 5 floors. Classified in use group 2 (common medium-sized works) according to the classification of RPA99/2003 (Article 3.2).

This work is located in EL-MATCH wilaya of Skikda which are classified as Medium Seismic Zone (zone IIa), according to RPA 99/2003 (SEISMIC CLASSIFICATION OF WILAYAS AND COMMUNITIES OF ALGERIA)

#### I.2.1 Geometric characteristics:

They are represented in the following table:

**Tableau I.1: Geometry of the structure**

Dimensions of the work	(m)
Total height	18.87
Floor height	3.06
Ground floor height	3.06
Total length of building	25.60
Total width of the building	21.10

#### I.2.2 Site category:

**Table I.2: Site data**

Location at	SKIKDA
The zone	IIa
Usage group	2
The site is	S3
The admissible soil stress	$\sigma = 0.80 \text{ bars}$
Depth of anchorage	D=2m

#### I.2.1 Carrier system:

Bracing is a static system intended to ensure the overall stability of a structure with respect to horizontal effects resulting from possible actions on it (for example: wind, earthquake, shock, braking, etc.). It also serves to locally stabilize certain parts of the structure (beams, posts) relatively instability phenomena (buckling or spilling).

The function of the framework is to ensure the stability of the assembly which is stressed by:

- Our building exceeds four (04) levels or fourteen (14 meters) and is located in (zone IIa).
- Gantry bracing is therefore ruled out (Art.3.4.A.1.b of RPA99/version 2003), therefore the choice will be worn on supporting sails (sails and gantries).
- The gantries must absorb, in addition to the stresses due to vertical loads, at least 25% of the effort cutting edge.

### **I.2.2 Floor:**

The floors are horizontal elements called “diaphragm” which ensure the functionality of the structure and which allow the transmission of forces to the bracing elements.

- A floor must be resistant to vertical and horizontal loads.
- A floor must ensure thermal and acoustic insulation of the different floors.

There are two types of slabs:

- Solid reinforced concrete slab: it is intended where hollow body floors cannot be made (the balconies, bedroom slab and shechoir and stairs).
- Hollow body slab: all the floors of the ground floor and the 5 floors are made of hollow body slab except a small part.

### **I.2.3 stairs :**

Are non-structural elements, allowing passage from one level to another with two flights and an inter-floor landing. The building has only one type of staircase, a straight staircase in reinforced concrete cast on site.

### **I.2.4 The Balconies:**

These are consolidated areas at the level of each floor, they will be made in solid slabs.

### **I.2.5 Masonry :**

The most used masonry in ALGERIA is hollow bricks for this work we have two wall types:

- **Exterior walls:** The facades are filled with masonry, they are made up of a double partition made of hollow bricks (15+10) thick with an air gap 5 cm thick.
- **Interior walls:** 10 cm partition wall.

### **I.2.6 The Coverings:**

- Cement coating for exterior walls and partitions.
- Plaster coating for ceilings.
- Tiled coverings for floors and stairs.
- Ceramic for kitchen walls and bathrooms.
- The terrace floor will be covered by waterproof multi-layer waterproofing preventing the penetration of rainwater.

### **I.2.7 Acroterium:**

As the terrace is inaccessible, the top level is surrounded by a reinforced concrete parapet with a height of 60 cm and thickness of 10 cm.

The role of the parapet:

- allow the insulation and waterproofing coverings of the roof terraces to be raised vertically on its internal face (watertightness survey).
- to prevent the flow of rainwater.

### **I.2.8 The Terrace:**

The terrace of our building is inaccessible.

### **I.2.9 The Infrastructure:**

This is the part of the construction located below the ground, it contains :

- **The foundations:**

It is the part buried in the ground which transmits the loads and overloads of the construction to the ground. The choice of foundation types depends on the type of soil and the size of the work.

## **I.4 Security And Regulations :**

The stability and durability of the structure depends on the resistance of the different structural elements. (posts, beams, sails, etc.) to the different stresses (compression, bending, etc.) including the resistance of these elements depends on the types of materials used and their dimensions and characteristics.

The materials provided for the realization of this work as well as the actions and requests must be comply with CBA 93 standards (BAEL 91 equivalent) and meet the requirements and recommendations of Algerian seismic regulation RPA99. the structure of our building is designed with reinforced concrete, which is constructed of concrete and steel.

### **I.4.1 Algerian Seismic Regulations (Rpa99 Version 2003):**

RPA 99/2003 is a regulatory technical document which sets out the rules for the design and calculation of constructions in seismic zones (article 1.1 RPA 99/2003).

These rules aim to ensure acceptable protection of human lives and structures from effects of seismic actions through appropriate design and sizing.

For current works, the objectives thus sought consist of providing the structure:

Of sufficient rigidity and strength to limit non-structural damage and prevent damage structural by an essentially elastic behavior of the structure in the face of a moderate earthquake, relatively common.

Adequate ductility and energy dissipation capacity to allow the structure to undergo inelastic displacements with limited damage and without collapse or loss of stability, facing a major earthquake, more rare (article 1.2 RPA 99/2003).

#### **I.4.2 Regulatory Technical Document (D.T.R. - B.C. 2.2) “Permanent Loads And Operating Expenses”:**

This document deals with the “permanent loads” and “operating loads” of buildings, their method of evaluation and the values of these loads to be introduced into the calculations.

#### **I.4.3 General Information On The C.B.A 93 (The Bael 91 Rules):**

The calculation is based on the theory of limit states. A limit state is a particular state for which a condition required for a construction (or one of its elements) is strictly satisfied, and would cease to be so in the event of an unfavorable modification of an action. Beyond a limiting state the structure (or one of its elements) is decommissioned, that is to say that it will no longer respond to the functions for which it was designed. There are two (02) categories of limit states:

##### **I.4.3.1 Ultimate Limit States (ELU):**

Corresponding to the limit:

- Either static balance of construction (no overturning or tilting).
- Or the resistance of one of the materials (no breakage).
- Or stability of form (the ruin of an element of the structure by loss of stability before reaching the resistance).

##### **I.4.3.2 Calculation Assumptions At ELU (C.B.A 93 A.4.3.2):**

- The resistance of tensile concrete (to traction) is neglected.
- Straight sections remain flat after deformation (Navier hypothesis).
- Concrete-steel adhesion leads to equal deformations, a consequence of non-slip.
- The stress-strain diagram of concrete and steel is linear.
- The relative shortening of the most compressed concrete fiber is limited to 3.5‰ in bending and 2‰ in simple compression. The relative elongation of the tensest reinforcements, assumed to be concentrated in their center gravity, is limited to 10‰.
- The positions that the deformation diagram of a straight section can take pass at least by one of the three pivots A,B,C (the three pivot rule).- We can assume concentrated at its center of gravity the section of a group of several tensioned bars or compressed, provided that the error thus committed on the unit deformation does not exceed 15‰.

### **I.4.3.3 Service Limit States (ELS) :**

This is the condition that a structure must satisfy so that its normal use and durability are ensured, exceeding it will imply a disorder in the functioning of the structure, there are three limit states :

- Service limit state with respect to the compression of the concrete: This limit makes it possible to avoid the problem of cracking of concrete which under cyclic load may break or fatigue.
- Limit state of crack opening: in this state we limit the tensile stress of the steels, we distinguish three (03) types of cracking: slightly detrimental, detrimental and very detrimental.
- Limit state of deformation: any element subjected to stress deforms, it is therefore essential to limit any deformation under any type of stress in the structure.

### **I.4.3.4 ELS Calculation Assumptions (C.B.A. Regulation 93 A.4.5.1):**

-The straight sections remain flat and there is no relative sliding between the concrete and the reinforcements outside the immediate vicinity of the cracks.

-Steel and concrete are considered linearly elastic materials and are disregarded shrinkage and creep of concrete.

-Tensed concrete is neglected.

-There is no relative slip between concrete and steel.

-By convention the ratio  $n$  of the longitudinal modulus of elasticity of steel to that of concrete or coefficient equivalence to value 15.

-In accordance with usual errors, we do not deduct in the calculations the area of the steels from the air of the concrete compressed, we can also assume concentrated at its center of gravity the steel air of the cross section of a group of several reinforcements, provided that the error thus committed does not exceed 15%.

### **I.4.3.5 Rule Of The Three Pivots:**

The simplest way to characterize the behavior of reinforced concrete is to think about deformations, following their linearity and their measurability.

The pivot is defined as being a fixed limit deformation point, from which we will determine the possible deformations in the section for all stresses.

According to the analysis of the behavior of concrete-steel materials, we can define three pivots:

**-Pivot A:** the limit state is defined by reaching the limit elongation of 10‰ of the most tense reinforcement: the section is subjected to simple traction, simple or compound bending.

**-Pivot B:** the limit state is defined by reaching the limit shortening of 3.5‰ of the most compressed fiber: the section is subjected to simple or compound bending.

**-Pivot C:** the limit state is defined by reaching the limit shortening of 2‰ at a distance from the fiber more compressed equal to  $\frac{3}{7}$  of the total height  $h$  of the section (as results from the properties of the similar triangles in the diagram below: these are fully compressed and subject to bending compound or simple compression).

## **I.5 Action And Requests :**

### **I.5.1 Action (Regulation C.B.A 93 A.3.1):**

The actions of forces and torques due to loads applied to the structure (permanent, climatic, operational, seismic, etc.). And the imposed deformations (shrinkage, temperature variation, settlement of supports, etc.)

Actions are classified into three categories based on their frequency of appearance:

### **I.5.2 permanent Actions G:**

The intensity of which is constant or very little variable over time, they include:

- The self-weight of the structure.
- Efforts due to earth or liquids whose levels vary little.
- Fixed equipment costs.
- Forces due to permanent deformations imposed on the structure (shrinkage, creep, settlement, etc.).

### **I.5.3 Qi Variable Action:**

The intensity of which varies frequently and significantly over time, we distinguish:

- Operating overloads (DTR B.C.2.2).
- Climate actions (DTR C.2.47 RNV99).
- Actions due to temperature.

### **I.5.4 Fa Accidental Actions:**

These are actions originating from rare phenomena (earthquakes, shocks, explosions, etc.), with a very short duration. of application.

### **I.5.5 Solicitations (Regulation C.B.A 93 A.3.2):**

The stresses are forces (normal force, shear force), moments (bending moment, twisting moment) calculated from the actions using appropriate methods.

The calculations are carried out using scientific methods supported by experimental data.

### **I.5.6 Requests For Calculation Of Combinations Of Actions (Regulation C.B.A 93 A.3.3):**

The justifications produced must show for the various elements of a structure and for the entire this, that the calculation requests do not cause the phenomenon that we should avoid. We designate by:

-G<sub>max</sub>: All unfavorable permanent actions.

-G<sub>min</sub>: All favorable permanent actions.

-Q<sub>j</sub>: The so-called basic variable set.

-Q<sub>i</sub> (i>1) other variable so-called supporting actions.

ψ<sub>0</sub>, ψ<sub>1</sub>, ψ<sub>2</sub> coefficients defined in (C.B.A Regulation 93 A.3.1.3.1)

### **I.5.7 Calculation Requests With Respect To The Ultimate Resistance Limit States:**

#### **I.5.8 Fundamental Combination (C.B.A. Regulation 93 A.3.3.2.1):**

During long-term or transitional situations, it is necessary to consider:

$$1.35G_{\max} + G_{\min} + \gamma Q_1 + \sum 1.3\psi_i Q_i$$

with

-γQ<sub>1</sub> = 1.5 in the general case.

-γQ<sub>1</sub> = 1.35 in special cases (temperatures, agricultural buildings with low human occupancy density, closely limited operating costs or of a particular character).

#### **I.5.9 Accidental Combination (C.B.A. Regulation 93 A.3.3.2.2):**

$$G_{\max} + G_{\min} + FA + \psi_1 Q_1 + \sum 1.3\psi_2 Q_i$$

With :

-FA: Nominal value of the accidental action.

-ψ<sub>1</sub>Q<sub>1</sub>: Frequent value of a variable action.

-ψ<sub>2</sub>Q<sub>i</sub>: Quasi-permanent value of another variable action.

### **I.5.10 Calculation Requests With Respect To The Ultimate Service Limit States (C.B.A 93 A.3.3.3):**

They result from the following combination of actions called rare combinations:

$$G_{max} + G_{min} + Q_1 + \sum \psi_{0i} Q_i$$

### **I.5.11 Verification Of Static Balance (C.B.A 93 A.3.3.4):**

The static balance of all or part of the structures must be checked for each assembly phase and for the complete structure.

### **I.5.12 Verification Of Shape Stability (C.B.A 93 A.3.3.5 And A.4.4):**

The justification of shape stability consists of demonstrating that there exists a state of constraints which balances calculation requests, including those of second order, and which is compatible with countability and the design strength of the materials.

### **I.5.11 Material Characteristics:**

The characteristics of the materials used in construction will comply with the technical rules of design and calculation of reinforced concrete structures CBA 93, the regulation of reinforced concrete in limit states namely BAEL 91, as well as the Algerian seismic regulation RPA 99/2003.

### **I.5.12 Concrete (CBA .93 (A.2.1)):**

#### **I..5.12.1 Definition:**

Concrete is a material made up of a mixture of aggregate (gravel, sand), binders (cement) and water.

in well-defined proportions, for the realization of this work is a common concrete to obtain at the time of implementation a suitable consistency and after hardening of the required qualities.

#### **I.5.12.2 Concrete Dosage:**

The concrete that we will use includes for 1 m<sup>3</sup>:

- Cement: 350 kg/m<sup>3</sup> (CPJ42.5).
- Gravel: 800 L/m<sup>3</sup> ( $D \leq 25\text{mm}$ ).
- Sand: 400 L/m<sup>3</sup> ( $D \leq 5\text{mm}$ ).
- Water: 175 L/m<sup>3</sup>.

**I.5.12.3 Mechanical Resistance Of Concrete:****I.5.12.4 Characteristic Resistance To Compression (C.B.A 93 A.2.1.1.1):**

concrete is characterized by its good compressive strength at the age of 28 days, called characteristic value required. When the stresses are exerted on the concrete at an age of  $j$  days, we have two cases:  $j \leq 28$  days.

$$f_{cj} = \left( \frac{j}{4.76 + 0.83j} \right) f_{c28} \text{ pour : } f_{c28} \leq 40 \text{ Mpa}$$

$$f_{cj} = \left( \frac{j}{0.41 + 0.95j} \right) f_{c28} \text{ pour : } f_{c28} > 40 \text{ Mpa}$$

$j > 28$  days

$f_{cj} = f_{c28}$ : Checking the resistance of the sections.

$f_{cj} = 1.1 f_{c28}$  Evaluation of deformations.

It is generally given from tests carried out in the laboratory:

- 15 – 20MP a at 28 days  $\rightarrow$  Average quality concrete.
- 20 – 25MP a at 28 days.  $\rightarrow$  Good quality concrete.
- 35MP a at 28 days  $\rightarrow$  Very good quality concrete.

In this study we take:  $f_{c28} = 25 \text{ MPa}$

**I.5.12.5 Tensile Strength Of Concrete (BAEL A.2.1.12):**

The characteristic tensile strength of concrete at the age of  $j$  days is conventionally defined by the relationship :

$$f_{tj} = 0.6 + 0.06 f_{cj} \text{ en Mpa pour : } f_{cj} \leq 60 \text{ Mpa}$$

$$f_{tj} = 0.275 f_{cj}^{\frac{2}{3}} \text{ en Mpa pour : } f_{cj} > 60 \text{ Mpa}$$

**I.5.12.6 Longitudinal deformation modulus (C.B.A 93. A.2.1.2):**

The longitudinal deformation modulus of concrete is given by the following formula:

- Instantaneous module: for loads applied before 24 hours.

$$E_{ij} = 11000 * (f_{cj})^{\frac{1}{3}}$$

In this study :  $E_{ij} = 11000 * (25)^{\frac{1}{3}} = 32164.195 \text{ Mpa}$

- The deferred module: for long-term loads.

$$E_{vj} = 3700 * (f_{cj})^{\frac{1}{3}}$$

In this study:  $E_{vj} = 3700 * (25)^{\frac{1}{3}} = 10818.86 \text{ Mpa}$

$f_{tj} = 0.6 + 0.06f_{cj}$  en Mpa pour :  $f_{cj} \leq 60 \text{ Mpa}$   $f_{tj} = 0.275f_{cj}^{\frac{2}{3}}$  en Mpa pour :  $f_{cj} > 60 \text{ Mpa}$

In this study ;  $f_{t28} = 0.6 + 0.06 * 25 = 2.1 \text{ Mpa}$

#### **I.5.12.7 Poisson's Ratio (C.B.A 93. A.2.1.3):**

We call Poisson's ratio the ratio of the relative transverse deformation to the relative longitudinal deformation.

$\nu = 0.2$  for the calculation of deformations and for the justifications for ELS (uncracked concrete).

$\nu = 0$  for the calculation of stresses and in the case of ELU (cracked concrete).

#### **1.5.12.8 Other Properties of Concrete:**

a) Density (Dtr B.C.2.2): We Have The Following Values:

- Unreinforced concrete  $\rho = 22 \text{ KN/m}^3$

- Reinforced concrete  $\rho = 25 \text{ KN/m}^3$

b) Expansion Coefficient:

The expansion coefficient of concrete is of the order of  $(0.7 - 1.2) * 10^{-5}$ , it is of the same order as that of steel. In the calculations we adopt as expansion coefficients the value  $10^{-5}$ .

c) Concrete limit stresses:

d) Limit Stress To Compression ELU (BAEL A.4.3.41) And (C.B.A 93 A.4.3.4.1):

The stress admissible compression at the ultimate limit state (ULS) is given by:

$$\overline{\sigma}_{bc} = \frac{0.85f_{cj}}{\theta\gamma_b} \text{ en Mpa}$$

With :

–  $\gamma_b = 1.5$  for common cases.

–  $\gamma_b = 1.15$  for accidental situations.

–  $\theta$ : depends on the duration of application of the loads.

–  $\theta = 1 \Rightarrow$  if the duration of application of the loads is greater than 24 hours.

–  $\theta = 0.9 \Rightarrow$  if the load application duration is between 1 hour and 24 hours.

-θ = 0.85 => if the duration of load application is less than 24 hours.

a) Limit Stress At Els (C.B.A 93.A.4.5.2):

The admissible compressive stress in the state service limit (ELS) is given by:

$$\bar{\sigma}_{bc} = 0.6 * f_{cj}$$

$$\bar{\sigma}_{bc} = 0.6 * 25 = 15 \text{ Mpa}$$

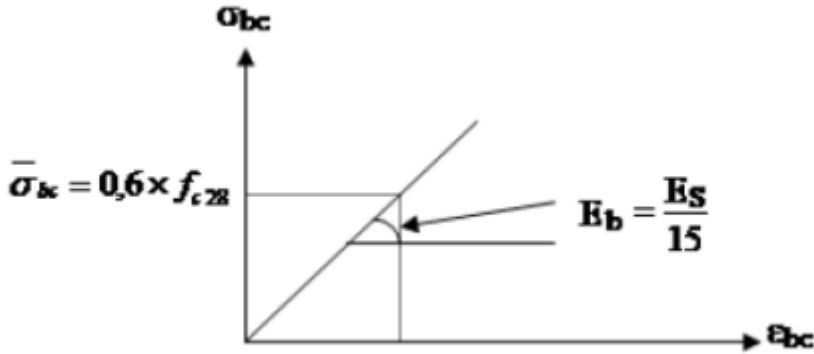

Figure 1.1 : Compressive stress, deformation diagram at the ELS

b) Stress-Strain Diagrams (C.B.A 93 A.4.3.4):

Stress deformation diagram for concrete calculation: The stress σbc deformation εbc calculation diagram can be used in all cases. It is made up of a parabola arc of the second degree, followed by a line segment. This segment extends between the values 2‰ and 3.5‰

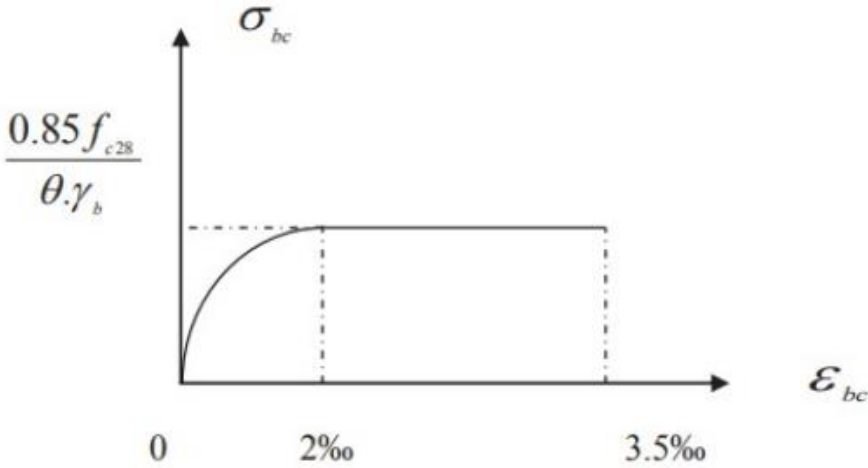

Figure 1.2 : Compressive stress, deformation diagram at the ELU

c) Shear Stress In Concrete At The E.L.U (C.B.A 93 A.5.1.2.1):

The ultimate shear stress is given by:

- **Minor damage cracking :**

$$\tau_u \leq (0.2 \frac{f_{cj}}{\gamma_b}; 5\text{Mpa}) = 3.33\text{Mpa}$$

- **Detrimental and very detrimental cracking :**

$$\tau_u \leq 0.15 \frac{f_{cj}}{\gamma_b}; 4\text{Mpa} = 2.5\text{Mpa}$$

With:  $\tau_u$  is the ultimate shear stress (C.B.A 93 A.5.1.1)

### I.5.13 Steels:

#### a) Definition:

The steel material is an alloy of iron and carbon in low percentage, it is characterized by its good resistance in both traction and compression. Steels for reinforced concrete are soft grade from 0.15 to 0.25

#### I.5.13.1 Different Types Of Steel:

The steels used to make the reinforced concrete parts:

#### I.5.13.2 RI Smooth Rounds:

Smooth rounds are obtained by rolling mild steel. As their name suggests, their surface does not presents no roughness apart from rolling irregularities which are negligible, we use the grades FeE215 and FeE235 and standardized diameters 6,8, 10, 12, 14, 16, 20, 25, 32,40 and 50mm.

$f_e = 215 \text{ MPa}$  (stress at the elastic limit).

$f_u = 330 - 490 \text{ MPa}$  (stress at the breaking limit).

$f_e = 235 \text{ MPa}$ ,

$f_u = 410 - 490 \text{ MPa}$

#### I.5.13.3 High Adhesion Steels:

In order to increase concrete-steel adhesion, reinforcements with a special shape are used.

Gegenerally obtained by projecting ribs on the body of the frame. We have two classes of steel FeE400 and FeE500 and have the diameters of the smooth rounds.

The steels used in are FeE400 characterized by:

- the elastic limit: 400 MPa.
- Cracking coefficient:  $\eta = 1.6$ .
- Safety coefficient:  $\gamma_s = 1.5$  lasting situation,  $\gamma_s = 1$  accidental situation.
- Modulus of elasticity:  $E_s = 2.105 \text{ MPa}$  (C.B.A 93, A2.2.2).

**I.5.13.4 Welded Mesh:**

Welded mesh consists of wires crossing perpendicularly and electrically welded to their crossing points.

$\varphi > 6$  mm:  $f_e = 500$  MPa

$\varphi < 6$  mm:  $f_e = 520$  MPa

**I.5.13.5 Mechanical Characteristics:**

among the most important characteristics: the elastic limit  $f_e$  which is taken from the diagram stress-strain of steel. The values are presented in the table:

**Tab. 1.3: Values of the guaranteed elastic limit  $f_e$**

Types	Shade	Fe (Mpa)	Function
<b>Smooth rounds</b>	Fe E22	215	Current Employment. Lifting Pins Prefabricated Parts
	Fe E24	235	
<b>HA Type 1 And 2 Bars</b>	Fe E40	400	Current Employment.
	Fe E50	500	
<b>HA Type 3 Drawn Wires</b>	Fe E40	400	Use In The Form Of Bars Straight Or Lattice
	Fe E50	500	
<b>Type 4 Smooth Welded Mesh</b>	TSL	500	Current Employment.
	TSHA	520	

**I.5.13.6 Limit Stress Of Steels:**

The mechanical characteristics of steels are given empirically from tensile tests, in determining the relationship between  $\sigma$  and the relative deformation  $\epsilon$ .

**I.8.2.8 Ultimate Limit State :**

$$\sigma_s = \frac{f_e}{\gamma_s} \quad (1.12)$$

With:

$\gamma_s$ : safety coefficient.

such as :

$\gamma_s = 1.5$  Sustainable situation.

$\gamma_s = 1$  Accidental situation.

According to the regulation [BAEL91 Art A.2.2.2], the stress-strain diagram at the ULS is as follows:

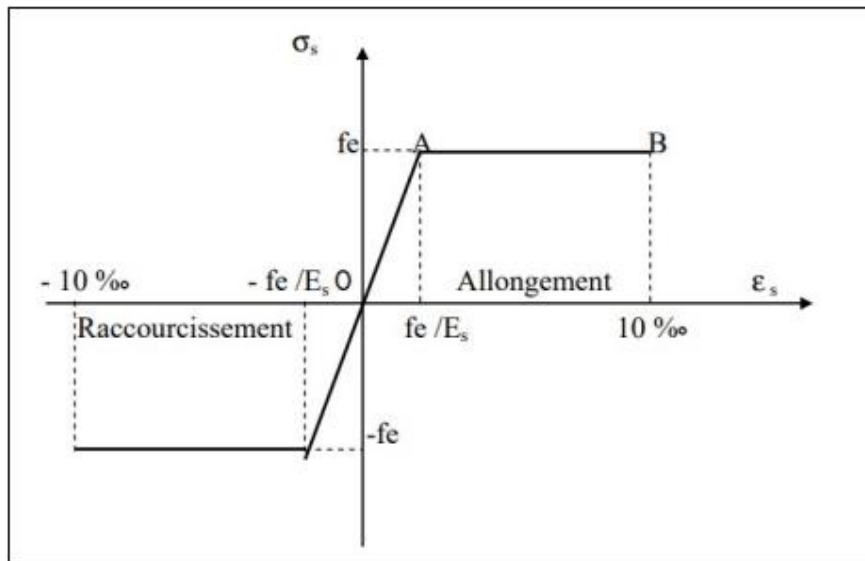

Figure1.2 :Stress-deformation diagram (Steel) at the ELU

**I.5.13.9 Service Limit State:**

State of limiting the opening of cracks (risk of corrosion of the reinforcements), and this is why; we must limit the stresses in the reinforcements stretched under the action of service requests, and according to BAEL91 rules, we distinguish three cases of cracking.

- **Slightly harmful cracking:** no verification required.

- **Detrimental cracking:**

$$\sigma_{\overline{s}} = \min\left(\frac{2}{3} fe; 110\sqrt{nft_j}\right) \quad (1.13)$$

$$\sigma_{\overline{s}} = 201.63\text{Mpa}$$

With :

$f_{tj}$ : Characteristic tensile strength of concrete in MPa.

$\eta$ : The cracking coefficient =  $\begin{cases} n = 1.6m: HA \geq 6mm \\ n = 1: \text{for mild steels} \\ n = 1.3: HA < 6mm \end{cases}$

The diameter of the reinforcements closest to the walls is at least or equal to 6mm.

- **Very Damaging Cracking:**

$$\sigma_{\overline{bc}} = \min\left(\frac{1}{2} fe; 90\sqrt{nft_j}\right)$$

$$\sigma_{\overline{s}} = 164.97\text{Mpa}$$

$\eta$ : The cracking coefficient  $\left\{ \begin{array}{l} n = 1.6: HA \geq 6mm \\ n = 1 \text{ for mild steels} \\ n = 1.3 ; HA < 6mm \end{array} \right.$

The diameter of the reinforcements closest to the walls is at least or equal to 6mm.

## 1.9 Conclusion:

The mechanical characteristics of the materials used in this study are summarized in the table:

**Tableau 1 I.4 Mechanical characteristics of the materials used**

values	Mechanical characteristic	Values(Mpa)
<b>Concrete</b>	Characteristic resistance ( $f_{c28}$ )	25
	Limit constraint to the ELU: sustainable situation accidental situation	14.2 18.84
	Limit stress at the SLS ( $\sigma_{bc}$ )	15
	Instantaneous longitudinal deformation modulus $E_{ij}$	32164.195
	Delayed longitudinal deformation modulus $E_{vj}$	10818,86
<b>Steel</b>	Yield strength $f_e$	400
	Modulus of elasticity	210000
	Calculation constraint at the ELU: accidental situation current situation	400 348
	Constraint to ELS Minor damage cracking Detrimental cracking Very damaging cracking	201.63 164.97

# CHAPTER II

## PRE-DIMENSIONING

## II.1. The objective of pre-dimensioning :

The objective of pre-dimensioning is to define the dimensions of the different elements of the structure, these dimensions are chosen according to the recommendations of **RPA 99/Version 2003, BAEL 91 modified 99** and **CBA 93**

## II.2. Pre-dimensioning of elements:

### II.2.1. The beams:

The beams are concrete load-bearing elements with built-in steel reinforcement serving as a base for transmitting the loads to the columns.

The pre-dimensioning of beams is performed according to the formulas of BAEL91 and verified using the RPA99-2003:

- $\frac{L_{max}}{15} \leq h_p \leq \frac{L_{max}}{10}$
- $0.3h_p \leq b_p \leq 0.7h_p$

With :

$h_p$  : Beam height

$b_p$  : Beam Width

$L_{max}$  : maximum range between bare supports of two main beams

Verifications according to **RPA 99/V2003 (art 7.5.1)** :

- $b_p \geq 20\text{cm}$
- $h_p \geq 30\text{cm}$
- $\frac{h_p}{b_p} \leq 4$

#### II.2.1.1. The main beams :

They are arranged perpendicular to the girders, the height is given depending on the condition of the arrow which is:

In our case :  $L_{max} = 505\text{cm}$

Depending on the conditions in **BAEL 91** :

$$\frac{505}{15} = 33.67\text{cm} \leq h_p \leq \frac{505}{10} = 50.5\text{cm}$$

We assume  $h_p=50\text{cm}$

$$0.3 \times 50 = 15\text{cm} \leq b_p \leq 0.7 \times 50 = 35\text{cm}$$

We assume  $b_p=35\text{cm}$

❖ Verifications :

According to the recommendations of RPA 99 (version2003), it must meet the following conditions :

$$h_p = 50 > 20\text{cm} \dots\dots\dots \text{cv}$$

$$b_p = 35 > 30\text{cm} \dots\dots\dots \text{cv}$$

$$\frac{h_p}{b_p} = \frac{50}{35} = 1.42 < 4 \dots\dots\dots \text{cv}$$

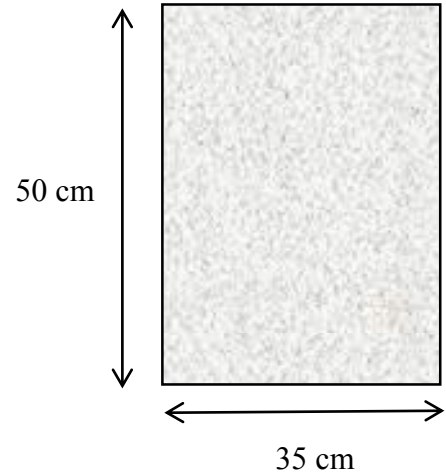

Note :

So we adopt for the main beams of a section :  $S = (50 \times 35)\text{cm}^2$

**II.2.1.2. The secondary beams :**

They are arranged parallel to the beams, height is given by :

In our case :  $L_{\text{max}} = 420\text{cm}$

Depending on the conditions in **BAEL 91** : 40

$$\frac{420}{15} = 28\text{cm} \leq h_p \leq \frac{420}{10} = 42\text{cm}$$

We assume  $h_p = 40\text{ cm}$

$$0.3 \times 40 = 12\text{cm} \leq b_p \leq 0.7 \times 40 = 28\text{cm}$$

We assume  $b_p = 35\text{ cm}$

Verifications :

According to the recommendations of RPA 99 (version2003), it must meet the following conditions :

$$h_p = 40 > 20\text{ cm} \dots\dots\dots \text{cv}$$

$$b_p = 35 > 30\text{ cm} \dots\dots\dots \text{cv}$$

$$\frac{h_p}{b_p} = \frac{40}{35} = 1.14 < 4 \dots\dots\dots \text{cv}$$

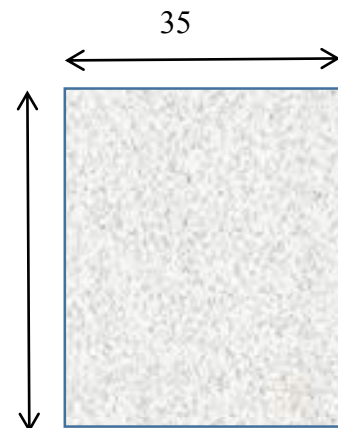

## II.2.2. the column :

The columns are vertical supporting elements with role:

- support vertical loads.
- Participate in transverse stability by beam column system to withstand Hz forces.

section of the pole is dimensioned as must meet:

Verifications :

According to RPA 99/Version 2003, and for zone □a:

- $\text{Min}(b, h) \geq 25\text{cm}$
- $\text{Min}(b, h) \geq \frac{h_e}{20}$

And  $h_e$  : floor height minus the fallout of the beam

$$\frac{1}{4} < \frac{b}{h} < 4$$

Takes the choice of architecture  $(35 \times 45)\text{cm}^2$

- $\text{Min}(35 \times 45) \geq 25\text{ cm} \rightarrow 35\text{ cm} > 25\text{cm} \dots\dots\dots\text{cv}$
- $\text{Min}(35 \times 40) \geq \frac{306}{20} \rightarrow 35\text{ cm} > 17\text{cm} \dots\dots\dots\text{cv}$
- $\frac{1}{4} = 0.25 < \frac{35}{45} = 0.77 < 4 \dots\dots\dots\text{cv}$

According to BAEL 91, we must verify that  $\lambda \leq 50$ .

$$\lambda = \frac{l_f}{i} \quad , i = \sqrt{\frac{I}{A}} \quad \text{with } I = \frac{b \times h^3}{12} \quad \text{and } A = b \times h$$

The column embedded on both sides, therefore :

- $l_f = 0.7 \times h_e = 0.7 \times 306 = 214.2\text{ cm}$
- $I = \frac{(35 \times (45)^3)}{12} = 265781.25\text{cm}^4$
- $A = 35 \times 45 = 1575\text{cm}^2$
- $i = \sqrt{\frac{265781.25}{1575}} = 12.99$
- $\lambda = \frac{214.2}{12.99} = 16.48 < 50 \dots\dots\dots\text{cv}$

There is no risk of buckling.

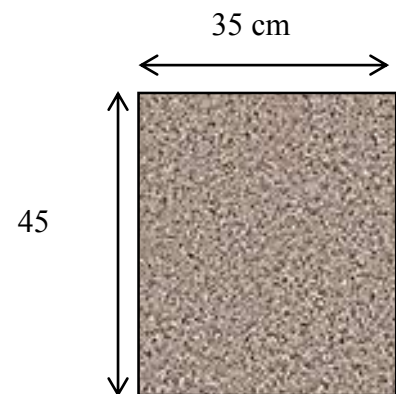

So we adopt a section of  $S = (35 \times 45)\text{cm}^2$

**Remark :**

We did this pre-dimensioning before the RPA99/V2003 verifications.

**II.2.3. Floors:**

A floor is a horizontal load-bearing element separating two floors of a building. The floors are supported either on walls or beams.

- Solid slab floors in reinforced concrete
- Prefabricated floors with prefabricated slabs
- Floors with hollow slabs and joists.

Hollow slab floors are used:

According to CBA93, the floor must be dimensioned according to the following condition :

$$h_t \geq \frac{L}{22.5}$$

$L$  : length of the beam between bare supports

$h_t$ : Floor height

We have :  $L = 390 \text{ cm}$

$$h_t \geq \frac{390}{22.5} = 17.33 \text{ cm}$$

So we adopt a floor  $h_t = 20 \text{ cm}$

(16cm hollow slab and 4cm compression slab)

**II.2.4.Joists :**

The joists are T sections made of reinforced concrete.

- $0.3h_t \leq b_0 \leq 0.6h_t$

With :  $h_t = 20 \text{ cm}$

- $0.3 \times 20 = 6 \text{ cm} \leq b_0 \leq 0.6 \times 20 = 12 \text{ cm}$

We adopt :  $b_0 = 10 \text{ cm}$

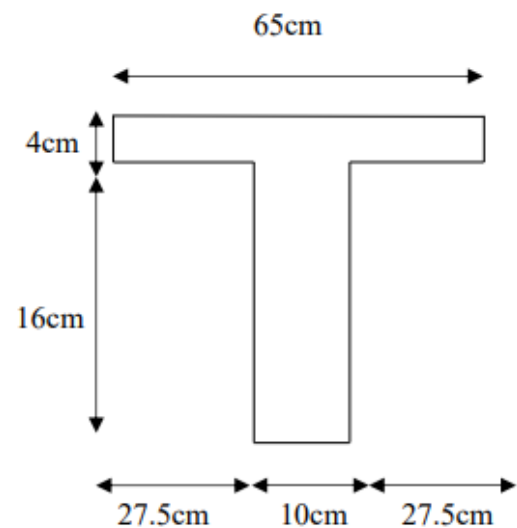

Figure II.1 : joist section

$$\bullet \quad b_1 \geq \min\left(\frac{L}{2}; \frac{L_{\max}}{10}\right)$$

With :  $L_{\max} = 390 \text{ cm}$

Therefore  $b = 2b_1 + b_0 = (2 \times 27.5) + 10 \rightarrow L = b - b_0 = 65 - 10 = 55 \text{ cm}$

$$b_1 \geq \min\left(\frac{55}{2} = 27.5; \frac{390}{10} = 39\right) \text{ cm}$$

We adopt  $b_1 = 27.5 \text{ cm}$

### II.2.5. The parapet :

It is a reinforced concrete element, embedded in the terrace floor and whose role is to prevent the infiltration of rainwater between the slope form and the terrace floor, its dimensions are mentioned in the architectural plans.

The calculation is done in compound bending.

$h$  : Parapet height

$h_0$ : thickness of the parapet.

With :  $h = 60 \text{ cm}$  and  $h_0 = 10 \text{ cm}$

$$S_T = S_1 + S_2 + S_3 + S_4$$

$$S_T = (0.6 \times 0.1) + (0.07 \times 0.1) + \left(\frac{0.1 \times 0.03}{2}\right)$$

$$S_T = 0.0685 \text{ m}^2$$

**Self-weight :**

$$G = (\gamma \times S_T) = (0.00685 \times 25) \\ = 1.7125 \text{ KN/ml} \rightarrow 0.17125 \text{ T / ml}$$

$$Q = 1 \text{ KN/ml} \rightarrow 0.1 \text{ T / ml}$$

### II.2.6. Balcony :

The balcony is calculated as a bracket recessed to the beams and subjected to a load and a concentrated operating load at the free end due to the dead weight of guardrail. This console is single-bending reinforcement.

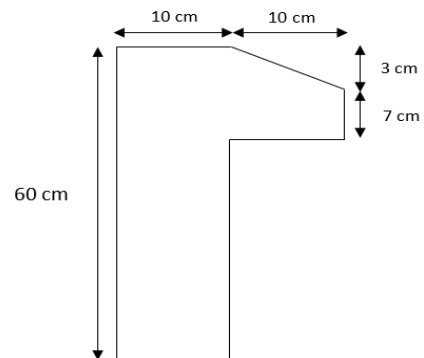

Figure II: Diagram of the parapet

The calculation is done for a 1m strip.

According to **BAEL 91**

- $\frac{h}{L} \geq \frac{1}{10}$

L : Width and equal to = 120cm

- $h \geq \frac{L}{10} = \frac{120}{10} = 12 \text{ cm}$

we adopt thickness h = 15 cm

### **II.2.7. The Sails :**

The walls are rigid elements made of reinforced concrete cast on site. They are intended for a part of the vertical loads (dead loads and overloads). And on the other hand, to ensure the stability of the structure under the effect of horizontal loading (effect earthquake or wind)

pre-dimensioning of reinforced concrete walls justified by Art 7.7.1 of RPA 99/V2003.

Elements satisfying condition  $L \geq 4a$  will be considered as sails and in the otherwise, will be considered linear elements. The thickness of the veil  $\{a\}$  will be Determined based on the stage clearance  $h_e$  and the stiffness at the ends such that The minimum thickness of the sails is  $a \geq 15\text{cm}$ .

With :

L : sail length.

a : The thickness of the sail.

$h_e$ : upstairs height.

$$a \geq \max\left(a_{\min}; \frac{h_e}{25}; \frac{h_e}{22}; \frac{h_e}{20}\right)$$

We have :  $h_e=306$  cm

For ground floor and current floor :

$$a_{\min} = 15 \text{ cm}$$

$$a \geq \frac{h_e}{25} = \frac{306}{25} = 12.25 \text{ cm}$$

$$a \geq \frac{h_e}{22} = \frac{306}{22} = 13.90 \text{ cm}$$

$$a \geq \frac{h_e}{20} = \frac{306}{20} = 15.34 \text{ cm}$$

$$a \geq \max(12.25; 13.90; 15.34)$$

$$a \geq 15.34 \text{ cm}$$

we adopt :  $a = 20$  cm

### II.2.8. The stairs :

The stairs are elements constituted by a succession of steps. They allow the passage walk between the different levels of a building. Stairs used in this work are reinforced concrete cast on site.

- ❖ Step : It is a portion of stairs which permits ascent & descent.
- ❖ Tread : It is the upper horizontal portion of step upon which the feet is placed.
- ❖ Riser : The vertical portion between each tread on the stair.
- ❖ Handrail : A handrail is a rail that is designed to be grasped by the hand so as to provide stability or support.
- ❖ Baluster : It is vertical member of wood or metal supporting the handrail.
- ❖ Newel Post : This is the vertical member which is placed at the ends of flights to connect handrail.
- ❖ Run : It is the total length of stairs in a horizontal plane, including landings.

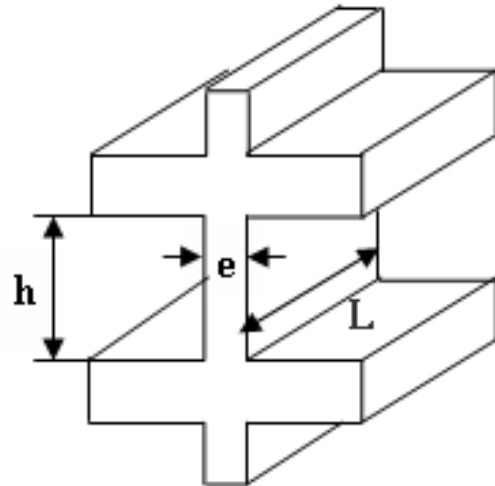

Figure II.3: Elevation sail cutting

- ❖ Nosing : It is the projecting part of the tread beyond the face of the riser. It is rounded to give good architectural effect.
- ❖ String or Stingers : These are the sloping wooden members which support the steps in a stair. They run along the slope of the stair.

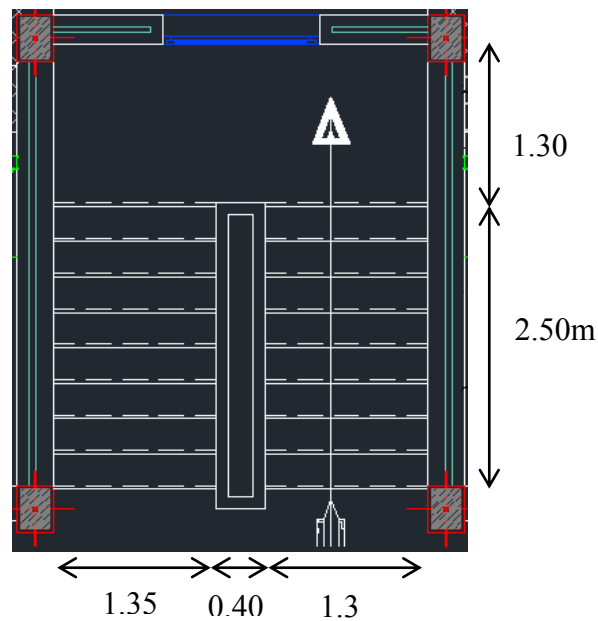

Figure II.4 : stair plan view

- For ground floor and current floor :

upstairs height :  $h_e = 306 \text{ cm}$

$h$  : hight of rise

$g$  : width of tread

**Practically** : the height  $h$  :  $14\text{cm} \leq h \leq 18 \text{ cm}$

The width  $g$  :  $25\text{cm} \leq g \leq 32 \text{ cm}$

We take :  $h = 17 \text{ cm}$  and  $g = 30 \text{ cm}$

BLONDEL formula :  $60 \leq 2h + g \leq 65$

$2h + g = (2 \times 17) + 30 = 64\text{cm} \rightarrow 60 \leq 64 \leq 65 \dots\dots\dots \text{cv}$

$n$  : number of risers

$H$  : floor height

$h$  : riser height

$$H = \frac{h_e}{2} = \frac{306}{2} = 153$$

$$n = \frac{H}{h} = \frac{153}{17} = 9 \text{ counter walking by volley}$$

$$n^* = n - 1 = 8 \text{ walking}$$

- Bench inclination:

$L$  : stride length.

$$L' = g \times (n - 1) = 30 \times (9 - 1)$$

$$L' = 240 \text{ cm}$$

$$L = \sqrt{L'^2 + H^2} = \sqrt{(240)^2 + (153)^2}$$

$$L = 284.62 \text{ cm}$$

$\alpha$  : The tilt nail.

$$\tan \alpha = \frac{H}{L'} = \frac{153}{240} = 0.6375 \quad \text{therefore } \alpha = 32.51^\circ$$

$e$  : The thickness of the bench and the bearing.

$$\frac{L}{30} = \frac{284.62}{30} \leq e \leq \frac{L}{20} = \frac{284.62}{20}$$

$$9.48 \leq e \leq 14.23$$

We adopt :  $e = 15 \text{ cm}$

### II.2.9. Platform Beam :

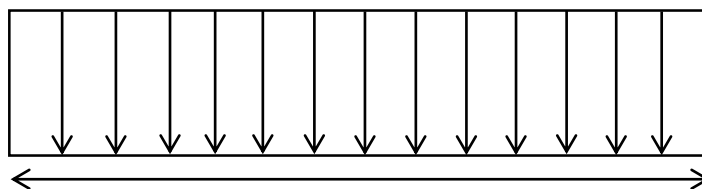

$L$  : the length of the beam between bare. 310 cm

- ❖ The height  $h$  of the landing beam must be:

According to **BAEL 91**, we have:

$$\frac{L}{15} \leq h \leq \frac{L}{10}$$

$$L = 310 \text{ cm}$$

$$\frac{310}{15} = 20.67 \text{ cm} \leq h \leq \frac{310}{10} = 31 \text{ cm}$$

We adopt :  $h = 35 \text{ cm}$

❖ The width **b** of the landing beam shall be :

According to **BAEL 91**, we have:

$$0.3 \times h \leq b \leq 0.7 \times h$$

$$(0.3 \times 35) = 10.5 \text{ cm} \leq b \leq (0.7 \times 35) = 24.5$$

We adopt :  $b = 30 \text{ cm}$

❖ Verification:

According to **RPA99/V2003** :

- $b \geq 20 \text{ cm}$
- $h \geq 30 \text{ cm}$
- $\frac{h}{b} < 4 \text{ cm}$

Either :  $h = 35 \text{ cm}$  ;  $b = 30 \text{ cm}$

- $b = 30 \text{ cm} > 20 \text{ cm} \dots\dots\dots \text{cv}$
- $h = 35 \text{ cm} > 30 \text{ cm} \dots\dots\dots \text{cv}$
- $\frac{h}{b} = 1.16 \text{ cm} < 4 \text{ cm} \dots\dots\dots \text{cv}$

A section was adopted :  $S = (30 \times 35) \text{ cm}^2$

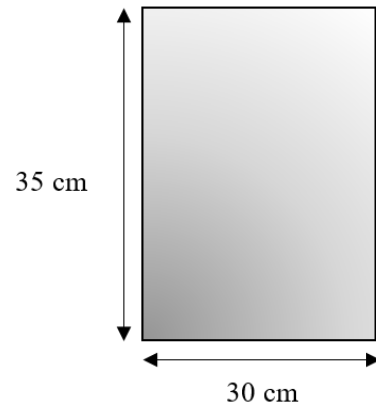

### □.3. Evaluation of the applied loads :

#### II.3.1. Inaccessible terrace floor :

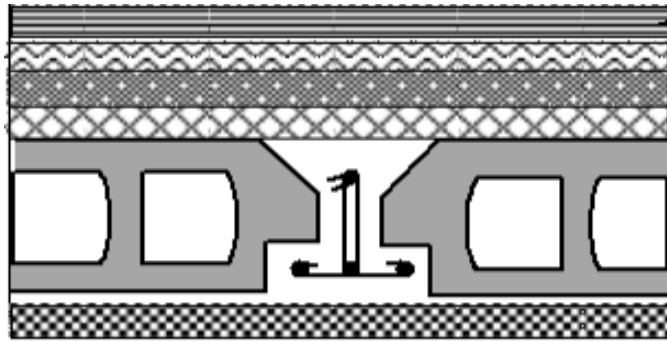

Figure II.5: shema of an inaccessible terrace slab

Table II.3.1 : dead loads returning to the inaccessible terrace slab.

Description	Weight (Kn/m <sup>3</sup> )	Thickness (m)	□G'' (Kn/m <sup>3</sup> )
Protection gravel	1700	0.04	68
Multilayer sealing	600	0.02	12
Concrete Slope Form	2200	0.07	154
Thermal insulation (cork)	400	0.04	16
Hollow slab	1425	0.20	285
Plaster coating	1400	0.02	28
Dead load (G)	-	-	<b>5.6</b>
Live load (Q)	-	-	<b>1.00</b>

#### II.3.2. current slab plan for residential use :

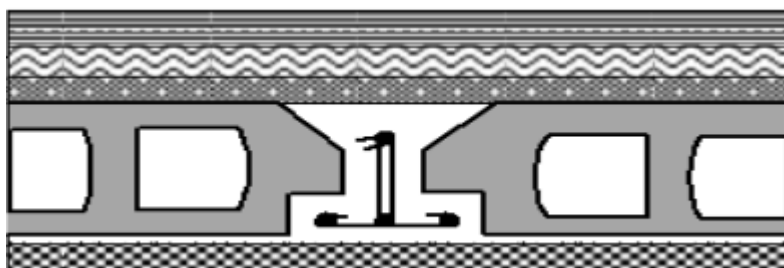

Figure II.6 : schema of a current floor slab

Table II.3.2 : dead loads due to the current level floor slab.

Description	Weight (Kg/m <sup>3</sup> )	Thickness (m)	□ G'' (Kn/m <sup>3</sup> )
Tiling	2200	0.02	44
Laying mortar	2000	0.03	60
Sandbed	1700	0.02	34
Hollow slab	1425	0.20	285
Plaster coating	1400	0.02	28
Distribution partition	75	0.10	75
Dead load (G)	-	-	<b>5.3</b>
live load (Q)	-	-	<b>1.5</b>

### II.3.3. Exterior Walls :

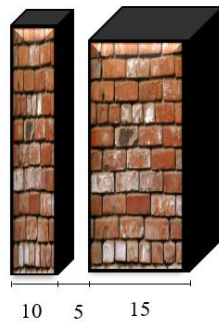

Figure II.7: Detail of the components of an exterior wall

Table II.3.3. Evaluation of exterior wall loads.

Description	Thickness (m)	Weight (Kg/m <sup>3</sup> )	□ G'' (Kn/m <sup>3</sup> )
Hollow Brick	0.15+0.10	13+9	2.85
Exterior cement mortar	0.02	18	0.36
Plaster coating	0.02	10	0.2
Dead load (G)	-	-	<b>3.41</b>

### II.3.4. Interior walls :



Figure II.8 : Detail of the components of an interior wall

Table II.3.4. Evaluation of interior wall loads

Description	Thickness (m)	Weight (Kg/m <sup>3</sup> )	□ G'' (Kn/m <sup>3</sup> )
Hollow Brick	0.1	9	0.9
Plaster coating	0.04	10	0.4
<b>Dead load (G)</b>	-	-	<b>1.3</b>

### II.3.5. Balcony :

Table II.3.4 Evaluation of balcony loads.

Description	Weight (Kg/m <sup>3</sup> )	Thickness (m)	□ G'' (Kn/m <sup>3</sup> )
Tiling	2200	0.02	44
Laying mortar	2000	0.03	60
Sandbed	1700	0.02	34
Hollow slab	2500	0.14	350
Plaster coating	1400	0.02	28
<b>Dead load (G)</b>	-	-	<b>5.16</b>

### II.3.6. The Sails :

Table II.3.4. Evaluation of sail loads.

Description	Thickness (m)	Weight (Kg/m <sup>3</sup> )	□ G'' (Kn/m <sup>3</sup> )
Ferroconcrete	0.2	25	5
Interior cement mortar	0.04	18	0.72
Dead load (G)	-	-	5.72

## II.4. Load descent :

### II.4.1. Introduction :

Load descent is the operation of calculating all loads that come to a load bearing element from the last level to the foundation. The loads considered concern the dead loads (the weight of the element, the weight of the floors, walls of facades..., etc.) and live loads

Regulatory burdens are generally :

- **Permanent load** : It is a question of taking into account the real weight of the elements put in place work to construct the building, to standardize and facilitate the procedures for calculation, The legislator provided lists of dimensional weights according to the materials Used. These lists are available in the **D.T.R** of dead loads and live loads.
- **Operating load** : Every building falls into a regulatory category and must be able to withstand the loads and stresses corresponding to (normal) use. It is easy to understand that the floor of a residential group is less loaded than the floor of a library.

### II.4.2. Center column :

Choice of the most used column :

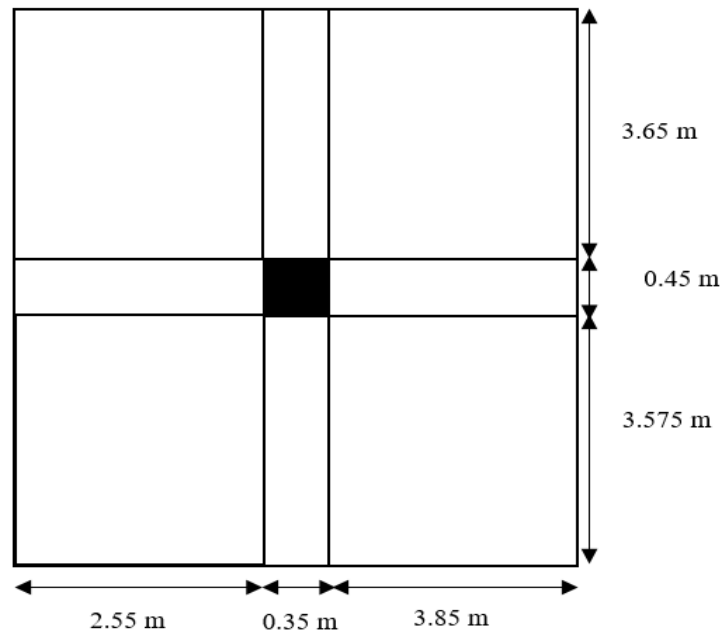

- **Surface of influence :**

$$S = (3.65 \times 2.55) + (3.65 \times 3.85) + (3.575 \times 2.55) + (3.575 \times 3.85)$$

$$S = 46.24\text{m}^2$$

- **surface gross :**

$$S = (2.55 + 0.35 + 3.85) \times (3.575 + 0.45 + 3.65)$$

$$S = 14.425\text{m}^2$$

**Table II.4.1. Load descent of Center column.**

Level	Elements	G (Kn) → (T)
1-1	Main beam = $4.375 \times 7.757$	33.141 → 3.3141
	Secondary beam = $3.5 \times 6.4$	22.4 → 2.24
	Terrace slab = 5.63	5.63 → 0.563
	Column = $3.94 \times 2.56$	10.08 → 1.008
	Total	71.25 → 7.125
2-2	Main beam = $4.375 \times 7.757$	33.141 → 3.3141
	Secondary beam = $3.5 \times 6.4$	22.4 → 2.24
	Current slab = $5.2 \times 46.24$	240.448 → 24.0448
	Column = $3.94 \times 2.56$	10.08 → 1.008
	Total	306.06 → 30.606
3-3	Main beam = $4.375 \times 7.757$	33.141 → 3.3141
	Secondary beam = $3.5 \times 6.4$	22.4 → 2.24
	Current slab = $5.2 \times 46.24$	240.448 → 24.0448
	Column = $3.94 \times 2.56$	10.08 → 1.008
	Total	306.06 → 30.606

<b>4-4</b>	Main beam = $4.375 \times 7.757$	33.141 → 3.3141
	Secondary beam = $3.5 \times 6.4$	22.4 → 2.24
	Current slab = $5.2 \times 46.24$	240.448 → 24.0448
	Column = $3.94 \times 2.56$	10.08 → 1.008
	Total	306.06 → 30.606
<b>5-5</b>	Main beam = $4.375 \times 7.757$	33.141 → 3.3141
	Secondary beam = $3.5 \times 6.4$	22.4 → 2.24
	Current slab = $5.2 \times 46.24$	240.448 → 24.0448
	Column = $3.94 \times 2.56$	10.08 → 1.008
	Total	306.06 → 30.606
<b>6-6</b>	Main beam = $4.375 \times 7.757$	33.141 → 3.3141
	Secondary beam = $3.5 \times 6.4$	22.4 → 2.24
	Current slab = $5.2 \times 46.24$	240.448 → 24.0448
	Column = $3.94 \times 2.56$	10.08 → 1.008
	Total	306.06 → 30.606

Center column :  $G = 1601.55 \text{ Kn/m}^2 \rightarrow 160.155 \text{ T/m}^2$

## II.5. Degression of loads :

### II.5.1. Introduction :

Each floor of a building is calculated for the maximum operating load it is expected to bear. however, As it is unlikely that all floors in a same construction are subject to, at the same time at their maximum operating load, one reduces the loads transmitted to pillars and foundations. The law of degression is set by the standards. This law is generally applicable for residential buildings.

- The law on the degression of loads applies to buildings with a large number of levels, or occupations of the various levels, can be considered independent. Levels occupied by industrial or commercial premises, are not counted in the number of floors involved in the law of degression, the charges on these floors are taken without abatement.

### II.5.2. Center column load degression:

Level	q (KN)	S (m <sup>2</sup> )	Q = q×S (KN/m <sup>2</sup> )	Degression	Q (KN)
<b>Terrace</b>	1	46.24	46.24	$Q_0$	46.24
<b>5th floor</b>	1.5	46.24	69.36	$Q_0 + Q_1$	115.6
<b>4th floor</b>	1.5	46.24	69.36	$Q_0 + 0.95(Q_1 + Q_2)$	178.024
<b>3th floor</b>	1.5	46.24	69.36	$Q_0 + 0.90(Q_1 + Q_2 + Q_3)$	233.512
<b>2th floor</b>	1.5	46.24	69.36	$Q_0 + 0.85(Q_1 + Q_2 + Q_3 + Q_4)$	282.98
<b>1st floor</b>	1.5	46.24	69.36	$Q_0 + 0.80(Q_1 + Q_2 + Q_3 + Q_4 + Q_5)$	323.68

<b>Ground floor</b>	0	46.24	0	$Q_0 + 0.75 + (Q_1 + Q_2 + Q_3 + Q_4 + Q_5 + Q_6)$	0
---------------------	---	-------	---	--	---

Center column :  $Q = 323.68 \text{ Kn} \rightarrow 32.368 \text{ t}$

- Load Combination :

$$N_u = 1.35G + 1.5Q = (1.35 \times 1601.55) + (1.5 \times 323.68)$$

$$N_u = 2647.61 \text{ Kn} \rightarrow 264.761 \text{ T}$$

- Buckling Verification :

$$\lambda = \frac{L_f}{i} \leq 50 \quad \text{with : } L_f = 0.7 \times h_e \quad ; \quad i = \sqrt{\frac{I}{A}} \quad ; \quad I = \frac{b \times h^3}{12} \quad ; \quad A = b \times h$$

$$h_e = 306 \text{ cm}$$

$$L_f = 0.7 \times 306 = 214.2$$

$$A = 35 \times 45 = 1575 \text{ cm}^2$$

$$I = \frac{35 \times (45)^3}{12} = 265781.25 \text{ cm}^4$$

$$i = \sqrt{\frac{265781.25}{1575}} = 12.99 \text{ cm}^2$$

$$\lambda = \frac{214.2}{12.99} = 16.48 < 50 \text{ no risk of buckling}$$

- Condition of Shape Stability :  $\overline{N}_u \geq N_u$

$$\overline{N}_u = \alpha \left( \frac{B_r \times f_{c28}}{0.9 \times \gamma_b} + A_{\min} \times \frac{f_e}{\gamma_s} \right)$$

$$\text{With : } \gamma_s = 1.15 \quad ; \quad \gamma_b = 1.5 \quad ; \quad f_{c28} = 25 \text{ MPa} \quad ; \quad f_e = 400 \text{ MPa}$$

$B_r$ : Reduced section of a column, obtained by reducing its real section 1cm thick over its entire periphery  $\square B_r = (b - 2\text{cm}) \times (h - 2\text{cm}) \square$

$$B_r = (35 - 2) \times (45 - 2) = 1419 \text{ cm}^2$$

$A_{\min}$ : Reduced steel section

$$A_{\min} \geq \{4U; 0.2\% B\}$$

U : Perimeter on my section

B : The section of the column

$$A_{\min}^{\text{RPA}} = 0.8\% \times B \text{ (Zone IIA)}$$

$$A_{\min}^{\text{RPA}} = (0.8 \times 10^{-3}) \times (35 \times 45) = 12.6 \text{ cm}^2$$

$$A_{\min}^{\text{BAEL}} = \max \left\{ \begin{array}{l} \frac{0.2 \times b \times h}{100} = \frac{0.2 \times 35 \times 45}{100} = 3.15 \text{ cm}^2 \\ \frac{8 \times (b + h)}{100} = \frac{8 \times (35 + 45)}{100} = 6.4 \text{ cm}^2 \end{array} \right.$$

$$A_{\min}^{\text{BAEL}} = 6.4 \text{ cm}^2$$

$$\text{So : } A_{\min} = \max (6.4 ; 12.6) \text{ cm}^2 \text{ ; therefore : } A_{\min} = 12.6 \text{ cm}^2$$

$\alpha$  : Reducing ration taking into account the stability

$$\lambda \leq 50 \Rightarrow \alpha = \frac{0.85}{1 + 0.2 \left( \frac{\lambda}{35} \right)^2}$$

$$\alpha = \frac{0.85}{1 + 0.2 \times \left( \frac{16.48}{35} \right)^2} = 0.814$$

$$\overline{N}_u = 0.814 \left( \frac{0.1419 \times 25 \times 10^3}{0.9 \times 1.5} + \frac{0.00126 \times 400 \times 10^3}{1.15} \right)$$

$$\overline{N}_u = 3066.038 \text{ Kn} \Rightarrow 306.6038 \text{ T}$$

$$\overline{N}_u = 3066.038 \text{ Kn} > N_u = 2647.61 \text{ Kn} \dots\dots\dots \text{CV}$$

# CHAPTER III

## CALCULATION OF SECONDARY ELEMENTS

## Calculation of secondary elements

### III.1 Introduction:

Non-structural elements are elements which do not have a load-bearing or bracing function; their role is to ensure the safety and comfort of users.

The calculation of secondary elements is generally done under the action of permanent loads and operating overloads. However, some must be verified under the action of the seismic load, such as they must therefore be carried out in accordance with the recommendations of the regulations (CBA93, RPA99/2003).

In this chapter, we will approach the calculation of the following non-structural elements:

- Hollow body floors.
- Full slab balconies.
- The parapet.
- The stairs and the landing beam.

### III.2 Study Of The Parapet :

#### III.2.1 Introduction :

The parapet is a non-structural safety element which is located at the level of the terrace, intended to protect people from falling and to avoid water runoff on the facade.

The parapet is considered as a console embedded in the floor subject to its own weight (G), at a lateral force ( $F_p$ ) due to the seismic effect and a horizontal overload (Q) due to the handrail.

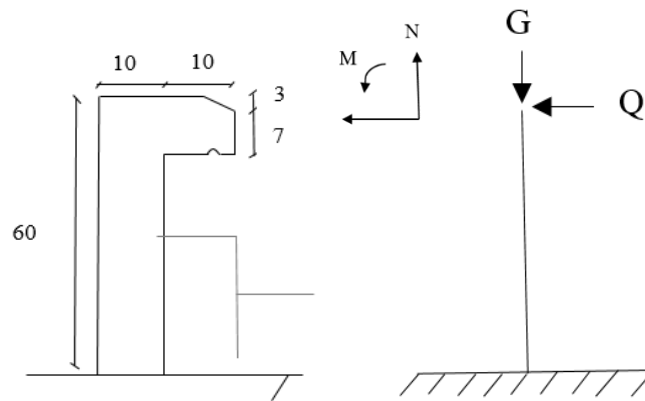

Figure III.1: Presentation of the static diagram of the parapet

### The surfec of the parpet :

$$S=0.0685 \text{ m}^2$$

### The own weight of the parpet:

$$G = \gamma * S = 0.00685 * 25 = 1.7125 \text{ KN/ml}$$

- Permanent load:  $G=1.7125 \text{ KN/ ml}$
- Operating expense:  $Q=1 \text{ KN/ml}$

### III.2.2. Checking the parpet for earthquakes:

According to RPA99/V2003 «art 6.2.3/Page59»

$$F_p = 4 A C_p W_p$$

**A** : Area acceleration coefficient obtained.

**C<sub>p</sub>**:horizontal force factor varying between 0.3 and 0.8.

**W<sub>p</sub>**:Weight of the elements considered.

According to RPA99/V2003 “Tab 4.1”, willaya of Skikda zone IIa seismicity use group 2:

- **A=0.15**

According to RPA99/V2003 “Tab 6.1”, element in console:

- **Cp=0.8**

Weight of the parapet:

- **Wp=1.7125 KN/ml**

$$F_p = 4 \times A \times C_p \times W_p = 4 \times 0.15 \times 0.8 \times 1.7125 = 0.82 \text{ KN} \rightarrow F_p = 0.082 \text{ t}$$

$$F_p = 0.82 \text{ KN} < Q = 1 \text{ KN} \dots \dots \dots \text{CV}$$

Therefore the parapet is stable with respect to seismic action.

### III.2.3 Requests:

-Normal effort:

$$N_G = 1.7125 \text{ KN/ml}$$

$$N_Q = 0 \text{ KN/ml}$$

We do not take into consideration the increase coefficients, because the weight of the parapet is a weight stabilizer “favorable effect Gmin.

-Bending moment: The moment due to the permanent load is zero:

$$M_G = 0 \text{ KN.m}$$

-The overturning moment due to the horizontal force:

$$M_Q = Q \times h = 1 \times 0.6 = 0.6 \text{ KN.m}$$

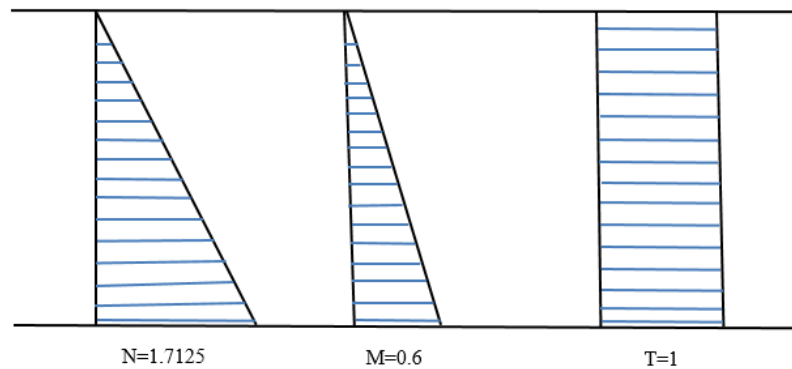

Figure III.2 : Internal Forces Diagram

### III.2.3.1 combination of actions :

- **ULS :**

$$N_U = N_G + 1.5N_Q = 1.7125 \times (1.5 \times 0) = 1.7125 \text{KN/ml} \quad \rightarrow N_U = 0.17125 \text{ t}$$

$$M_U = 1.35 \times M_G + 1.5 \times M_Q = 1.5 \times 0.6 = 0.9 \text{KN/ml} \quad \rightarrow M_U = 0.09 \text{ t}$$

$$T_U = 1.5 \times Q = 1.5 \times 1 = 1.5 \text{KN/ml} \quad \rightarrow T_U = 0.15 \text{ t}$$

- **SLS :**

$$N_{ser} = N_G + N_Q = 1.7125 \text{KN/ml} \quad \rightarrow N_{ser} = 0.17125 \text{ t}$$

$$M_{ser} = M_G + M_Q = 0.6 \text{KN/ml} \quad \rightarrow M_{ser} = 0.06 \text{ t}$$

### III.2.4 Reinforcement calculation:

The calculation section is rectangular with a width  $b = 100 \text{ cm}$  and a height  $h = 10 \text{ cm}$  (thickness). We adopt a covering of reinforcements of the type exposed to bad weather, so cracking is detrimental.

#### III.2.4.1 Determination of eccentricity at ULS(CBA93 A.4.3.5):

It is the distance between the center of pressure and the center of gravity of a section, according to article A.4.3.5 of the CBA93. We adopt a total calculation eccentricity:

$$e = e_1 + e_2 \text{ such as } e_1 = \frac{M_1}{N} + e_\alpha$$

with :

- $M_1$ : Theoretical 1st order moment.
- $e_1$ : The first order global eccentricity.
- $e_\alpha$ : Additional eccentricity.
- $e_2$ : eccentricity due to second order effects.

So :

$$e_1 = \frac{Mu}{Nu} = \frac{0.9}{1.7125} = 0.525\text{m}$$

$$e_\alpha = \max\left\{2\text{m}, \frac{L}{250}\right\} = \max\left\{2\text{m}, \frac{60}{250} = 0.24\text{cm}\right\} = 0.02\text{m}$$

$$e_2 = \frac{3 * L^2 f}{10000 * h} * (2 + \alpha\varphi)$$

$$\text{With : } \begin{cases} \varphi = 2 \\ Lf = 2 * L_0 = 2 * 0.6 = 1.2\text{m} \\ \alpha = 10 \left[1 - \frac{Mu}{1.5M_{ser}}\right] = 10 * \left[1 - \frac{0.9}{1.5 * 0.6}\right] = 0 \end{cases}$$

$$e_2 = \frac{3 * 1.2^2}{10000 * 0.1} * (2 + 0 * 2) = 0.00864 \text{ m}$$

The limit state of shape stability will be verified by increasing the real eccentricity with an eccentricity due to second order effects.

$$e_{\text{tot}} = e_1 + e_2 = 0.525 + 0.02 + 0.00864$$

$$e_{\text{tot}} = 0.553 \text{ m}$$

**III.2.4.2 The Filling Coefficient :**

$$\Psi_1 = \frac{Nu}{b \times h \times fbc}$$

$$\Psi_1 = \frac{1.7125 \times 10^{-3}}{1 \times 0.1 \times 14.20} = 0.00120$$

$$\Psi_1 = 0.00120 \leq 0.80 \text{ and } \Psi = 0.00120 \leq \frac{2}{3}$$

$$\varepsilon = \frac{1 + \sqrt{9 + 12\Psi_1}}{4 \times (3 + \sqrt{9 - 12\Psi_1})}$$

$$\varepsilon = \frac{1 + \sqrt{9 - 12 \times 0.00120}}{4 \times (3 + \sqrt{9 - 12 \times 0.00120})} = 0.166$$

$$e_{nc} = \varepsilon \times h$$

So :

$$e_{nc} = 0.166 \times 0.1 = 0.0166\text{m}$$

We have :

$$e_{tot} = 0.553\text{m} > e_{nc} = 0.0166$$

Therefore: The section is partially compressed and the ELU may not be reached (low effort), the centerpressure is outside the section.

We calculate our section at simple bending under the effect of a fictitious moment but equal to the moment byrelation to the center of gravity of the tension reinforcements:

**III.2.4.3 Reinforcement section:**

We calculate the fictitious moment:

$$M_{\text{ufictif}} = Mu + Nu \times \left(d - \frac{h}{2}\right) \quad \text{and} \quad Mu = Nu \times e$$

$$d = 0.9 \times h = 0.9 \times 0.1 = 0.09$$

$$M_{\text{ufictif}} = 0.9 + 1.7125 \left(0.09 - \frac{0.1}{2}\right) = 0.968 \text{ Kn.m}$$

We calculate the reduced moment :

$$u = \frac{M_{\text{ufictif}}}{b \times d^2 \times fbc}$$

$$u = \frac{0.968 \times 10^{-3}}{1 \times 0.09^2 \times 14.20} = 0.008415 \leq u_1 = 0.391 \Rightarrow A's = 0$$

$$\sigma_s = \frac{f_e}{\gamma_s} = \frac{400}{1.15} = 348 \text{ Mpa}$$

$$\alpha = 1.25(1 - \sqrt{1 - 2u})$$

$$\alpha = 1.25(1 - \sqrt{1 - 2 \times 0.0084}) = 0.0112 \leq 0.259 \Rightarrow \text{pivot A}$$

$$Bu = 0.8 \times \alpha = 0.8 \times 0.0112 = 0.00896$$

$$A_s = \frac{Bu \times b \times d \times fbc}{\sigma_s}$$

$$A_s = \frac{0.0089 \times 100 \times 9 \times 14.20}{348} = 0.329 \text{ cm} \quad \Rightarrow A_s = \mathbf{0.329 \text{ cm}^2}$$

$$A_{s\text{réel}} = A_{s\text{fictif}} - \frac{Nu}{\sigma_s}$$

$$A_{s_{\text{réel}}} = 0.329 \times 10^{-4} - \frac{1.7125 \times 10^{-3}}{348} = 0.28 \text{ cm}^2 \Rightarrow A_{s_{\text{réel}}} = \mathbf{0.28 \text{ cm}^2}$$

$$A_{s_{\text{réel}}} > 0$$

#### III.2.4.4 Condition of non-fragility (CBA93 Art A.4.2):

$$A_{s_{\text{min}}} \geq \max \left\{ \frac{b \times h}{1000} ; 0.23bd \frac{f_{t28}}{f_e} \right\}$$

$$A_{s_{\text{min}}} \geq \max \{ 10^{-4} \text{ m}^2 ; 1.08 \times 10^{-4} \text{ m}^2 \}$$

$$A_{s_{\text{min}}} = \mathbf{1.08 \text{ cm}^2}$$

So:

We adopt: **4HA8 = 2.01 cm<sup>2</sup>**

**Spacing:**

$$St = \frac{100}{4} = 25 \quad \Rightarrow \mathbf{e = 25 \text{ cm}}$$

#### III.2.4.5 Distribution frame:

$$A_r = \frac{A_s}{4}$$

So :

$$A_r = \frac{2.01}{4} = 0.50 \text{ cm}^2$$

We adopt **3HA8=1.51 cm<sup>2</sup>** spacing **e=20cm**.

#### III.2.4.6 Verification of the shear force (CBA93 Art A.5.1):

$$\tau_u = \frac{T_u}{b \times h} \leq \bar{\tau}_u$$

We have according to **CBA93 (A.5.1.2.1.1)**:

Detrimental cracking.

$$\bar{\tau}_u = \min \left\{ \frac{0.15 f_{c28}}{\gamma_b}; 4 \text{ MPA} \right\} = \min \{ 2.5 \text{ MPA}; 4 \text{ MPA} \} = 2.5 \text{ MPA}$$

$$\tau_u = \frac{T_u}{b d} = \frac{1.5 \times 10^{-3}}{1 \times 0.09} = 0.016 \text{ MPA} \leq \bar{\tau}_u = 2,5 \text{ MP a} \dots \dots \dots \text{CV}$$

### III.2.5 Verification at the SLS:

As cracking is detrimental, we must check the stress of the steels, as well as in the concrete:

- The maximum compressive stress of the concrete must not exceed the admissible limit:

$$\sigma_{bc} \leq \bar{\sigma}_{bc} = 0.6 \times f_{c28} = 15 \text{ MPA}$$

- The stress in tensioned steels does not exceed the admissible limit:

$$\sigma_s \leq \bar{\sigma}_s = \min \left\{ \frac{2}{3} f_e; 110 \sqrt{\eta f_{t28}} \right\} \dots \dots \dots \text{Cracking is harmful}$$

With :

$$\eta = 1.6$$

$$f_{t28} = 2.1 \text{ MPA}$$

So :

$$\bar{\sigma}_s = \min \left\{ \frac{2}{3} 400; 110 \sqrt{1.6 \times 2.1} \right\} = \min \{ 266.67; 201.63 \} \Rightarrow \bar{\sigma}_s = \mathbf{201.63 \text{ MPA}}$$

We solve the third degree equation:

$$z^3 + pz + q = 0$$

With :

$$e_0 \geq \frac{h}{6}$$

$$e_0 = \frac{M_{ser}}{N_{ser}} = \frac{0.6}{1.7125} = 0.350\text{m} \quad \Rightarrow e = 35\text{cm}$$

$e_0 = 0.35 > 0.016 \Rightarrow$  Therefore the section is partially compressed

$$c = \frac{h}{2} - e_0 = \frac{10}{2} - 35 = -30\text{cm}$$

C: the distance from the center of pressure and the most compressed fiber of the section.

$$p = -3c^2 + 90A's \frac{(c - d')^2}{b} + 90As \frac{(d - c)^2}{b}$$

$$p = -3(-0.3)^2 + 90 \times 2.01 \times 10^{-4} \times \frac{0.09 - (-0.3)}{1} = -0.263\text{m}^2$$

$$q = 2c^3 - 90A's \frac{c - d'}{b} - 90As \frac{d - c}{b}$$

$$q = 2(-0.3)^3 - 90 \times 2.01 \times 10^{-4} \times \frac{0.09 - (-0.3)}{1} = 0.05\text{m}^2$$

So the equation is :  $z^3 - 0.263 \times z + 0.05 = 0$

$$\text{We calculate: } \Delta = q^2 + \frac{4p^3}{27} = (0.05)^2 + \frac{4 \times (-0.263)^3}{27} = -1.04 \times 10^{-4} < 0$$

so :

$$\begin{aligned}\varphi &= \arccos\left(\frac{3q}{2p}\sqrt{\frac{-3}{p}}\right) = \arccos\left(-\frac{3 \times 0.05}{2 \times 0.263} \times \sqrt{\frac{-3}{-0.263}}\right) \\ &= \arccos(-0.9631) \Rightarrow \theta = 164.39^\circ\end{aligned}$$

$$a = 2\sqrt{\frac{-p}{3}} = 2 \times \sqrt{\frac{-(-0.263)}{3}} = 0.588$$

$$\begin{cases} z_1 = a \cos\left(\frac{\varphi}{3}\right) = 0.588 \times \cos(54.79) = 0.339\text{m} \\ z_2 = a \cos\left(\frac{\varphi}{3} + 120\right) = 0.588 \times \cos(174.79) = -0.585\text{m} \\ z_3 = a \cos\left(\frac{\varphi}{3} + 240\right) = 0.588 \times \cos(294.79) = 0.246\text{m} \end{cases}$$

We adopt :  $z=0.339\text{m}$

$$y_{\text{ser}} = z + c = \begin{cases} y_{\text{ser}} = 0.339 - 0.30 = 0.039\text{m} = 3.9\text{cm} & 0 \leq y_{\text{ser}} = 3.9\text{cm} \leq d \\ y_{\text{ser}} = -0.585 - 0.30 = -88.5\text{cm} \\ y_{\text{ser}} = 0.246 - 0.30 = -5.4\text{cm} \end{cases}$$

We adopt :  $y_{\text{ser}} = 3.9\text{cm}$

### III.2.5.1 Calculating the moment of inertia:

$$I = \frac{by_{\text{ser}}^3}{3} + 15[A_s(d - y_{\text{ser}})^2 + A'_s(y_{\text{ser}} - d')^2]$$

We have:  $A'_s=0$

$$I = \frac{1 \times (0.03)^3}{3} + 15[2.01 \times 10^{-4}(0.09 - 0.03)^2] = 2.26 \times 10^{-5}\text{m}^4$$

$$\mathbf{I=2.26 \times 10^{-5}\text{m}^4}$$

### III.2.5.2 Calculation of constraints:

$$K = \frac{N_{\text{ser}} \times Z}{I} = \frac{1.7125 \times 10^{-3} \times 0.33}{2.26 \times 10^{-5}} = 25\text{KN}$$

$$\sigma_{bc} = K \times y = 25 \times 0.03 = 0.76\text{Mpa} \leq \bar{\sigma}_{bc} = 15\text{Mpa} \dots \dots \text{cv}$$

$$\sigma_s = 15 \times K \times (d - y_{ser}) = 15 \times 25 \times (0.09 - 3.9) = 22.5\text{Mpa} \leq \bar{\sigma}_s = 201.6\text{Mpa}$$

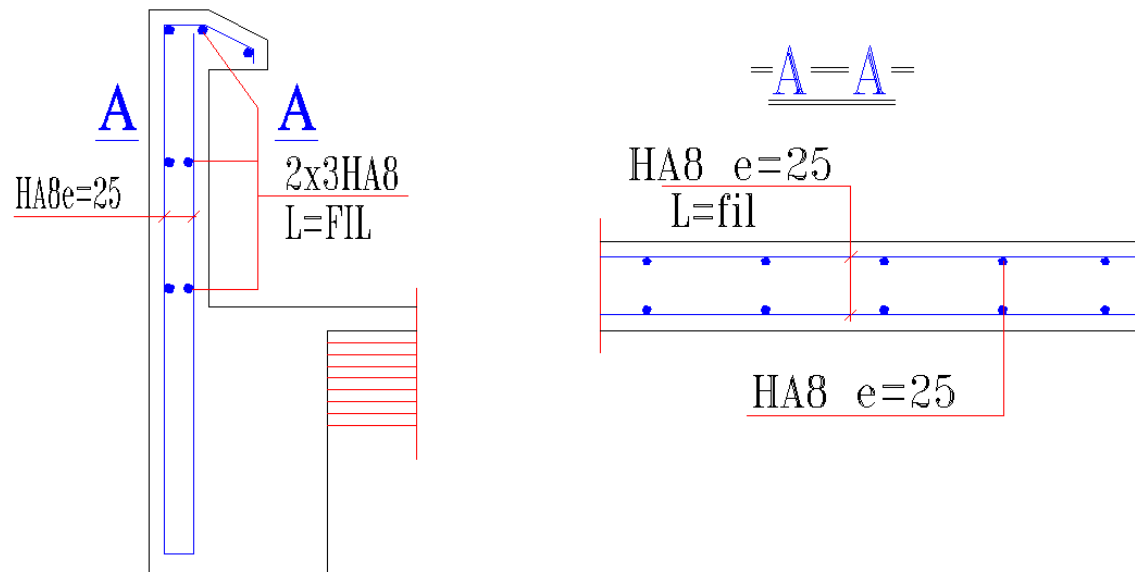

Figure III.3 : Reinforcement diagram of the parapet

**III.3.1. Introduction:**

The floors encountered in buildings of various uses or in industrial constructions must support their own weight, permanent loads and operating overloads and they transmit to the supporting elements; on the other hand they must isolate the different floors from the point of view acoustic and thermal, and contribute to resistance to horizontal forces.

**III.3.2. The different types of floors:**

There are several types of floors but the most commonly used are:

- Hollow body floor
- Solid slab floor

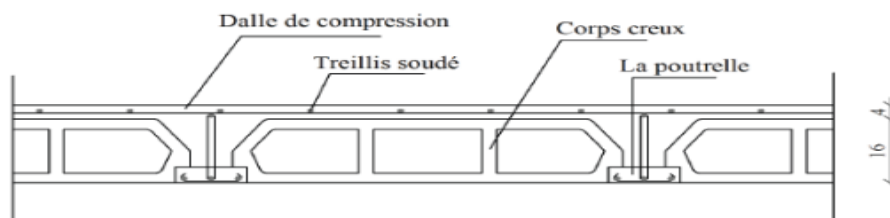

Figure III.4 : Descriptive diagram of a hollow body floor

In our project, the floor is made up of:

- Prefabricated beams which are arranged according to the small span, they provide a function of lift, the distance between axes of two neighboring beams is 65 cm.
- Hollow body which is used as permanent formwork and which also serves for thermal and sound insulation.
- A reinforced concrete compression slab.

For the calculation of floors, we use either exact methods or approved approximate methods by regulation “CBA 93”.

### III.3.3. The compression slab :

The compression slab having a role distribution of vertical loads on the beams, as well as to resist the efforts applied to the slab; Reinforcement is planned in a grid. This slab has a thickness of 4cm with a spacing of 65 cm between axes of beams.

The reinforcement section to be provided must satisfied with the following conditions: CBA93 Art[B.6.8.4.2.3]

- Spacing for reinforcements perpendicular to the ribs:  $a_1 \leq 20 \text{ cm}$
- Spacing for reinforcements parallel to the ribs:  $a_2 \leq 33 \text{ cm}$

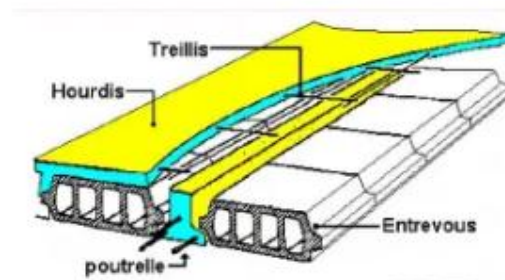

Figure III.5 : compression slab

The reinforcement section in the direction perpendicular to the ribs is given by:

$$A_{\perp} \geq \frac{200}{f_e} \text{ if } L \leq 50\text{cm}$$

$$A_{\perp} \geq 0.02L \frac{200}{f_e} = \frac{4L}{f_e} \text{ if } 50\text{cm} \leq L \leq 80\text{cm}$$

With :

- L :spacing between rib axes
- Fe: steel grade FeE400 ( $f_e=400$ )
- $A_{\perp}$  :section of reinforcement perpendicular to the ribs.

In our work, we have:  $L = 65$  cm, therefore:

$$50\text{cm} \leq L \leq 80\text{cm} \Rightarrow A_{\perp} \geq 0.02L \frac{200}{f_e} = \frac{4 \times 65}{400} = 0.65\text{cm}^2/\text{ml}$$

We take : 5HA6=1.41cm<sup>2</sup>/ml , with a spacing of 20 cm.

The reinforcement section in the direction parallel to the ribs is given by:

$$A_{\parallel} \geq \frac{A_{\perp}}{2} = \frac{1.41}{2} \Rightarrow A_{\perp} \geq 0.71$$

We take : 5HA6=1.41cm<sup>2</sup>/ml , with a spacing of 20 cm.

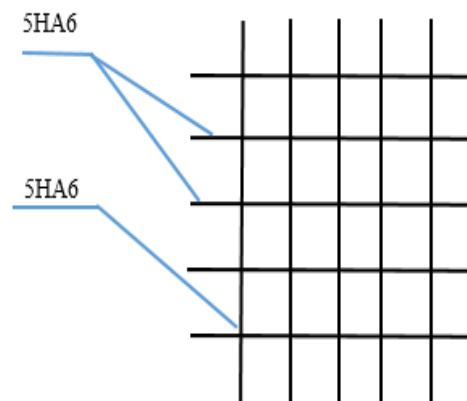
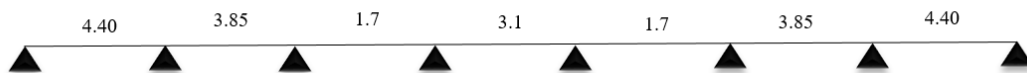

Figure III.6 :Reinforcement of the compression slab

**The beams** are calculated for simple bending.

### III.3.3.1 Types of beams :

The terrace and standard floors have the same dimensions.



FigureIII.7 :Beams Type 01

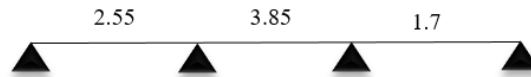

FigureIII.8 :Beams Type 02



FigureIII.9 : Beams Type03

The methods used for the calculation of continuous reinforced concrete beams are:

- Simplified method.
- Caquot method.

### III.3.3.2 Flat rate method:

According to BAEL 91 (Art B.6.2.10)

The method applies to common constructions (residential building, local offices) or the load operating load is also equal to two (02) times the permanent load we have:

$$Q \leq \max(2G, 5000N/ml)$$

It only applies to deflected elements (beams or slabs calculated in bending in one direction) meeting the following conditions:

- The moments of inertia are the same in the different bays.
- The successive spans of the spans are in a ratio between (0.8 and 1.25).
- cracking is considered to be of little harm.

**III.3.3.3 Application of the method:****Type 01 :**

$$Q \leq \max (2 \times G , 5000N/ml)$$

$$Q \leq \max(2 \times 5.6 , 5000N/ml) \Rightarrow Q \leq 11.20 , 5000N/ml \Rightarrow 1 \leq 11.20 \text{ cv}$$

**Moments of inertia :**

We have the same section; therefore, the moments of inertia are the same in the different spans  $\Rightarrow CV$

**The report  $\frac{L_n}{L_{n+1}}$  :**

$$-0.85 \leq \frac{4.40}{3.85} = 1.14 \leq 1.25 \text{ cv}$$

$$-0.85 \leq \frac{3.85}{1.7} = 2.26 \leq 1.25 \text{ cnv}$$

$$-0.85 \leq \frac{1.7}{3.1} = 0.54 \leq 1.25 \text{ cv}$$

$$-0.85 \leq \frac{3.1}{1.7} = 1.82 \leq 1.25 \text{ cnv}$$

$$-0.85 \leq \frac{1.7}{3.85} = 0.44 \leq 1.25 \text{ cv}$$

$$-0.85 \leq \frac{3.85}{4.40} = 0.87 \leq 1.25 \text{ cv}$$

**Cracking:**

cracking is considered to be of little harm.  $\Rightarrow CV$

**Type 02:**

$$Q \leq \max (2 \times G , 5000\text{N/ml})$$

$$Q \leq \max 2 \times 5.6, 5000\text{N/ml} \Rightarrow Q \leq 11.20, 5000\text{N/ml} \Rightarrow 1 \leq 11.20 \text{ cv}$$

### Moments of inertia :

We have the same section; therefore, the moments of inertia are the same in the different spans  $\Rightarrow$  CV

The report  $\frac{L_n}{L_{n+1}}$  :

$$-0.85 \leq \frac{2.55}{3.85} = 0.66 \leq 1.25 \text{ cv}$$

$$-0.85 \leq \frac{3.85}{1.7} = 2.26 \leq 1.25 \text{ cnv}$$

### Cracking:

cracking is considered to be of little harm.  $\Rightarrow$  CV

### Type 03:

$$Q \leq \max (2 \times G , 5000\text{N/ml})$$

$$Q \leq \max 2 \times 5.6, 5000\text{N/ml} \Rightarrow Q \leq 11.20, 5000\text{N/ml} \Rightarrow 1 \leq 11.20 \text{ cv}$$

### Moments of inertia :

We have the same section; therefore, the moments of inertia are the same in the different spans  $\Rightarrow$  CV

The report  $\frac{L_n}{L_{n+1}}$  :

$$-0.85 \leq \frac{2.55}{3.85} = 0.66 \leq 1.25 \text{ cnv}$$

There are conditions that are not verified so we use the Caquot method.

### III.3.3.3 Caquot method (Appendix E.2 of BAEL91):

The Caquot method applies to beams, joists and slabs supporting operating loads high  $Q \geq 2G$  or  $Q \geq 5\text{KN}$ . It is applied when one of the three conditions of the Flat Rate method is not valid.

This method is a simplified continuity method which brings to the theoretical continuity method corrections to take into account the variation in the moment of inertia and the damping of the loading forces of successive spans. And so it consists of calculating the moments on supports from the loading adjacent spans, it will then be necessary:

Study the different load cases which give the maximum moments and shear forces.

#### III.3.3.3.1 Assessment and combination of loads :

The loads applied:

##### **Terrace floor:**

$$G = 5.6 \text{ kn/m}^2$$

$$Q = 1 \text{ kn/m}^2$$

##### **Current floor:**

$$G = 5.3 \text{ KN/M}^2$$

$$Q = 1.5 \text{ kn/m}^2$$

##### **Load combinations:**

- **Terrace floor:**

$$\text{ULS: } q_u = (1.35G + 1.5Q) \times 0.65 = (1.35 \times 5.6 + 1.5 \times 1) \times 0.65 = 5.89 \text{kn/ml}$$

$$\text{SLS: } q_{\text{ser}} = (G + Q) \times 0.65 = (5.6 + 1) \times 0.65 = 4.29 \text{kn/ml}$$

- **Current floor:**

$$\text{ULS: } q_u = (1.35G + 1.5Q) \times 0.65 = (1.35 \times 5.3 + 1.5 \times 1.5) \times 0.65 = 6.11 \text{ kn/ml}$$

$$\text{SLS: } q_{\text{ser}} = (G + Q) \times 0.65 = (5.3 + 1.5) \times 0.65 = 4.42 \text{ kn/ml}$$

Tab.III.1 Floor stresses

Floor	G(kn/m <sup>2</sup> )	Q(kn/m <sup>2</sup> )	b(m)	q <sub>u</sub> (kn/ml)	q <sub>ser</sub> (kn/ml)
Terrace Floor	5.6	1	0.65	5.89	4.29
Current Floor	5.3	1.5	0.65	6.11	4.42

### III.3.3.4 Evaluation of moments on supports :

According to (Annex E.2 of BAEL 91) We use the formula  $\Rightarrow M_a = \frac{q_w L'^3_w + q_e L'^3_e}{8.5(L'_w + L'_e)}$

The reduced lengths of each span L':

- L'=L: For an edge span with simple edge support
- L'=0.8L :For an intermediate span.

Tab.III.2 Moment on terrace floor support Type 1

Span	1	2	3	4	5	6	7	
q <sub>u</sub>	5.89							
L	4.40	3.85	1.7	3.1	1.7	3.85	4.40	
L'	4.40	3.08	1.36	2.48	1.36	3.08	4.40	
suports	1	2	3	4	5	6	7	8
Ma	0	10.60	4.95	3.21	3.21	4.95	10.60	0
q <sub>ser</sub>	4.29							
Ma <sub>ser</sub> (-)	0	7.72	3.61	2.34	2.34	3.61	7.72	0

Tab.III.3 Moment on current floor support Type 1

Span	1	2	3	4	5	6	7	
q <sub>u</sub>	6.11							
L	4.40	3.85	1.7	3.1	1.7	3.85	4.40	
L'	4.40	3.08	1.36	2.48	1.36	3.08	4.40	
suports	1	2	3	4	5	6	7	8
Ma	0	11.00	5.14	3.33	3.33	5.14	11.00	0
q <sub>ser</sub>	4.42							
Ma <sub>ser</sub> (-)	0	7.95	3.72	2.41	2.41	3.72	7.95	0

Tab.III.4 Moment on current floor support Type 2

Span	1	2	3
q <sub>u</sub>	6.11		

L	2.55	3.85	1.70
L'	2.55	3.08	1.70
suports	1	2	3
Ma	0	5.85	5.14
$q_{ser}$	4.42		
$Ma_{ser}(-)$	0	4.23	3.71

Tab.III.6 Moment on current floor support Type 3

Span	1	2
$q_u$	6.11	
L	2.55	3.85
L'	2.55	3.85
suports	1	2
Ma	0	8.28
$q_{ser}$	4.42	
$Ma_{ser}(-)$	0	5.98

### III.3.3.5 Evaluation of moments in spans :

We use the following formulas:

$$x_0 = L - \frac{v_w}{v_e - v_w} = \frac{L}{2} - \frac{M_w - M_e}{q \times L}$$

$$M0_x = \frac{qL}{2}x - \frac{q}{2}x^2$$

$$M_t = M0_x + M_w \left(1 - \frac{x}{L}\right) + M_e \frac{x}{L}$$

**Floor type 3 :** (current floor)

**Span (1.2) :ULS**

$$x_0 = \frac{2.55}{2} - \frac{0 + 8.28}{5.89 \times 2.55} = 0.74m$$

$$M_0 = \frac{5.89 \times 2.55}{2} \times 0.74 - \frac{5.89 \times 0.74^2}{2} = 3.94 \text{ kn.m}$$

$$M_t = 3.94 + 0 - \frac{8.28}{2.55} \times 0.74 = 1.69 \text{ kn.m}$$

**Span(2.3) :ULS**

$$x_0 = \frac{3.85}{2} - \frac{-8.28 - 0}{5.89 \times 3.85} = 2.28 \text{ m}$$

$$M_0 = \frac{5.89 \times 3.85}{2} \times 2.28 - \frac{5.89 \times 2.28^2}{2} = 10.55 \text{ kn.m}$$

$$M_t = 10.55 - 8.28 \left(1 - \frac{2.28}{3.85}\right) + 0 = 7.57 \text{ kn.m}$$

- **Beams Type 03 :**

**Tableau 1 Tab.III.7 Moment in span type 3 current floor**

Span	1		2	
$q_u$	6.11			
L	2.55		3.85	
L'	2.55		3.85	
suports	1	2	3	
Ma	0	8.28	0	
$X_0(\text{ELU})$	0.74		2.28	
$M_t(\text{ELU})$	1.69		7.57	
$q_{ser}$	4.42			
$Ma_{ser}$	0	5.98	0	
$X_0(\text{ELS})$	0.74		2.28	
$M_t(\text{ELS})$	1.22		5.47	

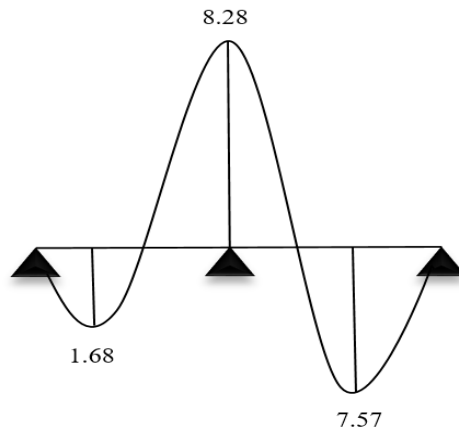

Figure III.10 : ULS moment diagram - beam Type 3 (current floor)

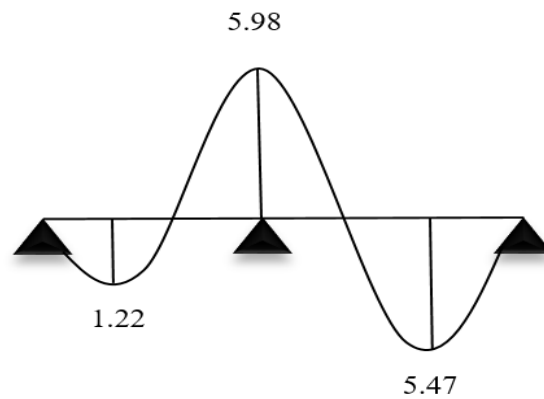

Figure III.11 : SLS moment diagram - beam Type 3 (current)

• **Beams Type 02 :**

**Tableau 2 Tab.III.8 : Moment in span type 2 current floor**

Span	1	2	3	
$q_u$	6.11			
L	2.55	3.85	1.7	
L'	2.55	3.08	1.7	
suports	1	2	3	4
$M_a$	0	5.85	5.14	0
$X_0(ELU)$	0.90	1.96	1.34	
$M_t(ELU)$	2.47	5.84	0.39	
$q_{ser}$	4.42			
$M_{a_{ser}}$	0	4.23	3.71	0
$X_0(ELS)$	0.90	1.96	1.34	
$M_t(ELS)$	1.79	4.22	0.28	

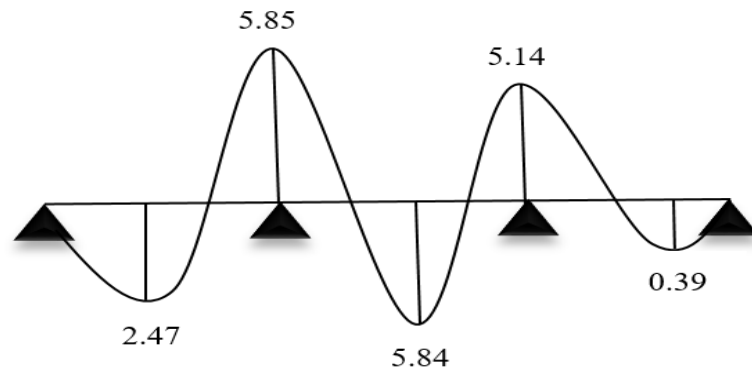

Figure III.14: ULS moment diagram - beam Type 2(current floor)

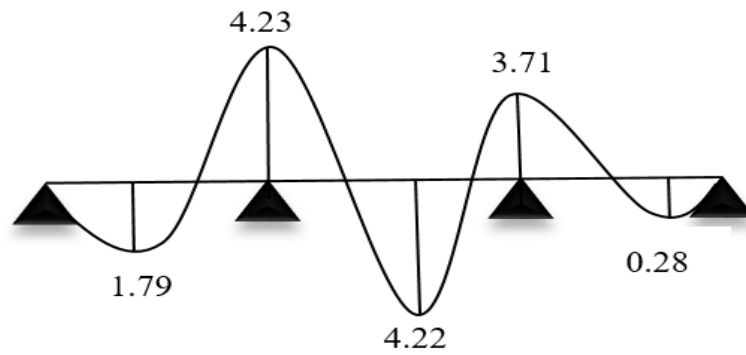

Figure III.15 : SLS moment diagram - beam Type 2

• Beams Type 01 :

Tab.III.9 : Moment in span type 1 terrace floor

Span	1	2	3	4	5	6	7	
$q_u$	5.89							
L	4.40	3.85	1.7	3.1	1.7	3.85	4.40	
L'	4.40	3.08	1.36	2.48	1.36	3.08	4.40	
suports	1	2	3	4	5	6	7	8
Ma	0	10.60	4.95	3.21	3.21	4.95	10.60	0
$X_0(ELU)$	1.79	2.17	1.02	1.55	0.68	1.68	2.61	
$M_t(ELU)$	9.45	3.32	1.86	3.87	1.86	3.32	9.45	
$q_{ser}$	4.29							
$Ma_{ser}$	0	7.72	3.61	2.34	2.34	3.61	7.72	0
$X_0(ELS)$	1.79	2.17	1.02	1.55	0.68	1.68	2.61	
$M_t(ELS)$	6.88	2.42	1.36	2.82	1.36	2.42	6.88	

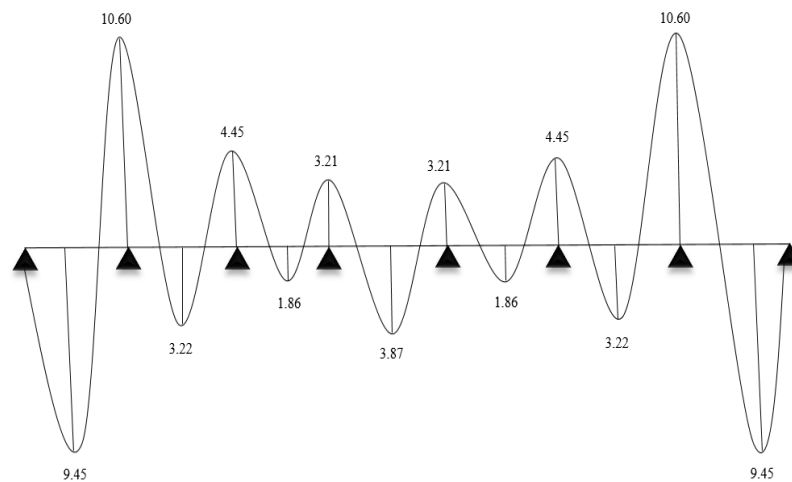
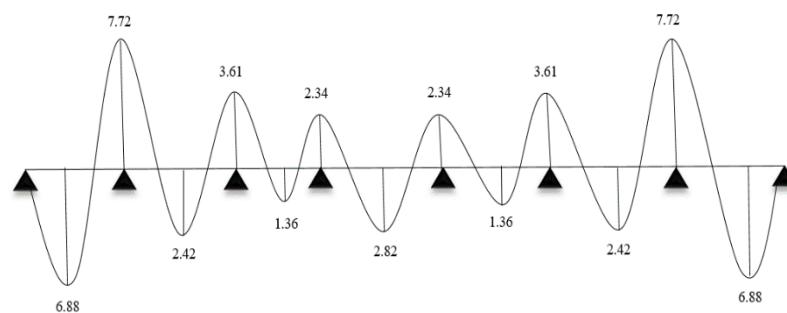

Figure III.16: ULS moment diagram - beam Type 1



FigureIII.17:SLS moment diagram - beam Type1

**Tab.III.10 : Moment in span type 1 current floor**

Span	1	2	3	4	5	6	7
$q_u$	6.11						
L	4.40	3.85	1.7	3.1	1.7	3.85	4.40
L'	4.40	3.08	1.36	2.48	1.36	3.08	4.40
suports	1	2	3	4	5	6	7
Ma	0	11,00	5,14	3,33	3,33	5,14	11,00
$X_0(ELU)$	1,79	2,17	1,02	1,55	0,68	1,68	2,61
$M_t(ELU)$	9,81	3,45	-1,93	4,02	-1,93	3,45	9,81
$q_{ser}$	4.42						
$Ma_{ser}$	0	7,95	3,72	2,41	2,41	3,72	7,95
$X_0(ELS)$	1,79	2,17	1,02	1,55	0,68	1,68	2,61
$M_t(ELS)$	7,09	2,49	-1,40	2,90	-1,40	2,49	7,09

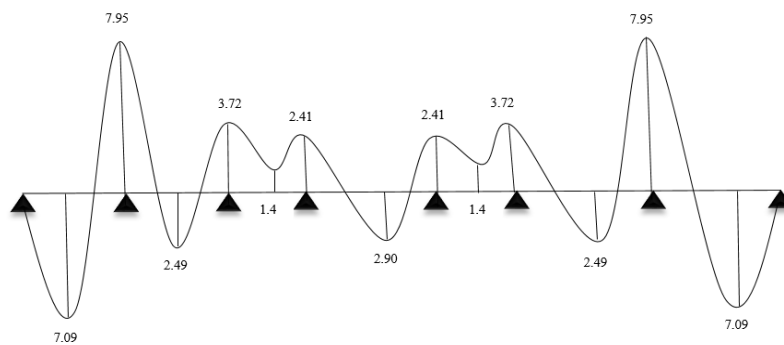

FigureIII.19: SLS moment diagram - beam Type 1 (current floor)

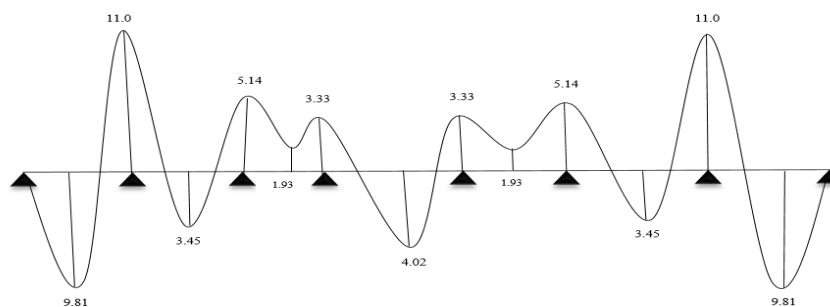

FigureIII.18: ULS moment diagram - beam Type 1 (current

### III.3.3.6 Evaluation of shear forces :

We use the formulas:

$$V_w = \frac{M_w - M_e}{L} = \frac{L}{2} - \frac{qL}{2}$$

$$V_e = V_w + qL$$

- Beams type 03 :

Current floor (Beams type 03)			
Span	1-2	2-3	
L(m)	2.55	3.85	
qu	6.11		
$Ma_{ELU}$	0	8.28	0
$V_w$	-4,55	-13,92	
$V_e$	11,04	9,62	

Tab III.11 :shear forces for current floor –beams type 03

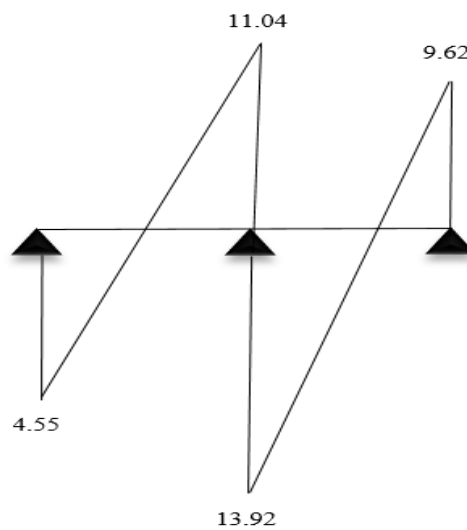

Figure III.20 : Diagram of shear forces for type 3 beam (current floor)

- Beams type 02:

Tab III.11 : shear forces for current floor –beams type 02

Current floor (Beams type 02)			
Span	1-2	2-3	3-4
L(m)	2.55	3.85	1.7
qu	6.11		
$Ma_{ELU}$	0	5,85	5,14
$V_w$	-5.50	-11.95	-8.22
$V_e$	10,09	11,58	2,18

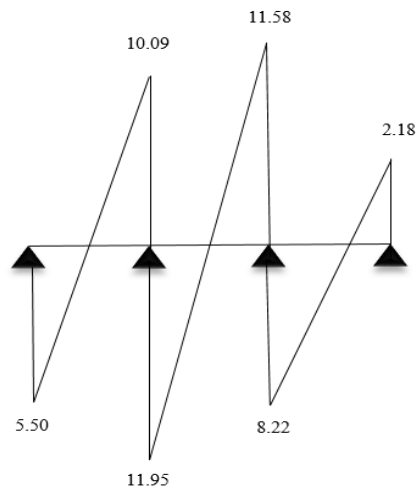

Figure III.21 : Diagram of shear forces for type 2 beam

- Beams type 01:

Tab III.12: shear forces for terrace floor –beams type 01

Terrace floor (Beams type 01)							
Span	1-2	2-3	3-4	4-5	5-6	6-7	7-8
$q_u$	5.89						
$Ma_{ELU}$	0	10,60	4,95	3,21	3,21	4,95	10,60
$V_w$	-10.55	-12.80	-6.03	-9.13	-3.98	-9.87	-15.36
$V_e$	15,36	9,87	3,98	9,13	6,03	12,80	10,55

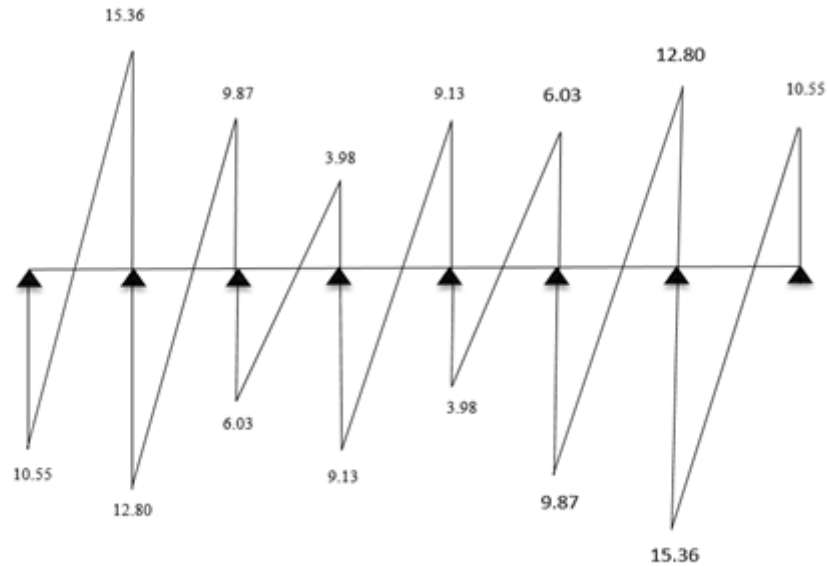

Figure III.22 : Diagram of shear forces for type 1 beam (Terrce floor)

Tab III.13:shear forces for current floor –beams type 01

Current floor (Beams type 01)							
Span	1-2	2-3	3-4	4-5	5-6	6-7	7-8
$q_u$	6,11						
$Ma_{ELU}$	0	11,00	5,14	3,33	3,33	5,14	11,00
$V_w$	-10,95	-13,29	-6,26	-9,48	-4,13	-10,25	-15,95
$V_e$	15,95	10,25	4,13	9,48	6,26	13,29	10,95

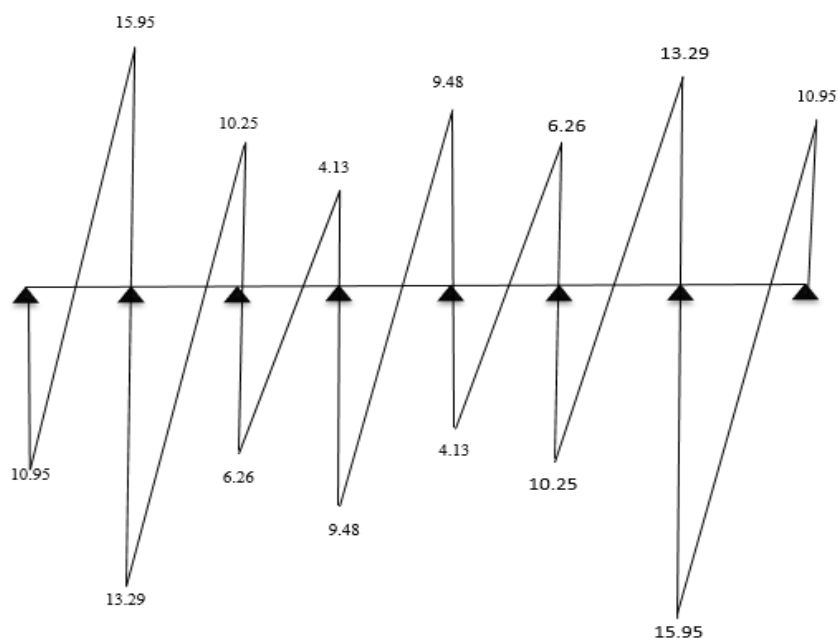

Figure III.23 : Diagram of shear forces for type 1 beam (Current floor)

### III.3.4 Reinforcement of beams at ULS :

According to the calculations of maximum stresses, the following results were obtained :

**Tab III.14 : Maximum loads type 1 (terrace floor)**

Terrace floor (Beams Type01)			
Limit states	$M_t$ (kN. m)	$M_a$ (kN. m)	$T_U$ (kN)
ULS	9.45	10.60	15.36
SLS	6.88	7.72	/

**Tab III.15 : Maximum loads type 1 (Current floor)**

Current floor (Beams Type01)			
Limit states	$M_t$ (kN. m)	$M_a$ (kN. m)	$T_U$ (kN)
ULS	9.81	11.00	15.95
SLS	7.09	7.95	/

**Tab III.16 : Maximum loads type 2 (current floor)**

Current floor (Beams Type02)			
Limit states	$M_t$ (kN. m)	$M_a$ (kN. m)	$T_U$ (kN)
ULS	5.84	5.85	11.95
SLS	4.22	4.23	/

**Tab III.17 :Maximum loads type 3 (current floor)**

Current floor (Beams Type03)			
Limit states	$M_t$ (kN. m)	$M_a$ (kN. m)	$T_U$ (kN)
ULS	7.57	8.28	13.92
SLS	5.47	5.98	/

The calculation will be done for a T-section subjected to simple bending.

We need to calculate the balanced moment  $M_{tab}$  supported by the compression table to determine the neutral axis position.

$$M - tab = \mu_0 * b * h * d^2 * f_{bc}$$

With  $\mu$  being a function of  $\alpha_0 = \frac{h_0}{d}$

It the following data:  $h = 20 \text{ cm}$ ,  $h_0 = 4 \text{ cm}$ ,  $b_0 = 10 \text{ cm}$ ,  $b = 65 \text{ cm}$

$$d = h - \left(1 + \frac{\emptyset}{2}\right) \quad \text{With } \emptyset \leq \frac{h}{10}$$

$$\text{We have : } h = 20 \text{ cm} \Rightarrow \emptyset = \frac{20}{10} = 2 \text{ cm} \Rightarrow d = 20 - (1 + 1) = 18 \text{ cm}$$

### III.3.4.1 In span :

$$\alpha_0 = \frac{0.04}{0.18} = 0.222 \Rightarrow 0.166 \leq \alpha_0 \leq 0.259$$

$$\mu_0 = 1.14\alpha_0 - 0.57\alpha_0^2 - 0.07 = 1.14 \times 0.222 - 0.57 \times 0.222^2 - 0.07 = 0.155$$

$$M_{tab} = 0.155 \times 0.65 \times 0.18^2 \times 14.2 = 46,35 \text{ KN.m}$$

So :

**Tab III.18 verification  $M_{ut} \leq M_{tab}$**

Type	$M_{ut}(\text{kN.m})$	$M_{tab}(\text{KN.m})$	$M_{ut} \leq M_{tab}$
1(current floor)	9.81	46,35	cv
2(current floor)	5.84	46,35	cv
3(current floor)	7.57	46,35	cv

So the neutral axis is within the compression zone, and the calculation is performed under simple bending with a section  $(bxh)=(65 \times 20)$ .

$$\mu_0 = \frac{M_u}{b \times d^2 \times f_{bc}}; \mu \leq \mu_l \Rightarrow A'_s = 0$$

$$\alpha = 1.25 \times (1 - \sqrt{1 - 2\mu})$$

$$z = d \times (1 - 0.4\alpha)$$

$$A_s = \frac{M_u}{z \times \sigma_s}$$

### Terrace floor Type 01 :

$$\mu_0 = \frac{9.45 \times 10^{-3}}{0.65 \times 0.18^2 \times 14.2} = 0.031 \leq \mu_l = 0.392 \Rightarrow A'_s = 0$$

$$\alpha = 1.25 \times (1 - \sqrt{1 - 2 \times 0.031}) = 0.039$$

$$Z = d \times (1 - 0.4\alpha) = 18 \times (1 - 0.4 \times 0.040) = 17.72$$

$$A_s = \frac{9.45 \times 10^{-3}}{17.72 \times 10^{-2} \times 348} = 1.53 \times 10^{-4} \text{m}^4 = 0.15 \text{cm}^2$$

**Current floor Type 01 :**

$$\mu_0 = \frac{9.81 \times 10^{-3}}{0.65 \times 0.18^2 \times 14.2} = 0.032 \leq \mu_1 = 0.392 \Rightarrow A'_s = 0$$

$$\alpha = 1.25 \times (1 - \sqrt{1 - 2 \times 0.032}) = 0.040$$

$$Z = d \times (1 - 0.4\alpha) = 18 \times (1 - 0.4 \times 0.040) = 17.71$$

$$A_s = \frac{9.81 \times 10^{-3}}{17.71 \times 10^{-2} \times 348} = 1.59 \times 10^{-4} \text{m}^4 = 0.16 \text{cm}^2$$

**Current floor Type 02 :**

$$\mu_0 = \frac{5.84 \times 10^{-3}}{0.65 \times 0.18^2 \times 14.2} = 0.019 \leq \mu_1 = 0.392 \Rightarrow A'_s = 0$$

$$\alpha = 1.25 \times (1 - \sqrt{1 - 2 \times 0.019}) = 0.023$$

$$Z = d \times (1 - 0.4\alpha) = 18 \times (1 - 0.4 \times 0.023) = 17.83$$

$$A_s = \frac{5.84 \times 10^{-3}}{17.83 \times 10^{-2} \times 348} = 9.41 \times 10^{-5} \text{m}^4 = 0.94 \text{cm}^2$$

**Current floor Type 03 :**

$$\mu_0 = \frac{7.57 \times 10^{-3}}{0.65 \times 0.18^2 \times 14.2} = 0.025 \leq \mu_1 = 0.392 \Rightarrow A'_s = 0$$

$$\alpha = 1.25 \times (1 - \sqrt{1 - 2 \times 0.025}) = 0.031$$

$$Z = d \times (1 - 0.4\alpha) = 18 \times (1 - 0.4 \times 0.031) = 17.77$$

$$A_s = \frac{7.57 \times 10^{-3}}{17.77 \times 10^{-2} \times 348} = 1.22 \times 10^{-4} \text{m}^4 = 0.12 \text{cm}^2$$

**Tab III.19: Calculate reinforcement for the span.**

Type	$\mu$	$\alpha$	Z	$A_s$	$A'_s$
1(Terrce floor)	0.032	0.039	17.72	0.15	0
1(current floor)	0.032	0.040	17.71	0.16	0
2(current floor)	0.019	0.023	17.83	0.94	0
3(current floor)	0.025	0.031	17.77	0.12	0

**III.3.4.2 At support :**

The calculation is performed on a rectangular section with a width  $b = b_0 = 10\text{cm}$  and a height  $h = 20\text{cm}$ .

$$\mu_0 = \frac{M_u}{b \times d^2 \times f_{bc}}; \mu \leq \mu_l \Rightarrow A'_s = 0$$

$$\alpha = 1.25 \times (1 - \sqrt{1 - 2\mu})$$

$$z = d \times (1 - 0.4\alpha)$$

$$A_s = \frac{M_u}{z \times \sigma_s}$$

**Terrace floor Type 01 :**

$$\mu_0 = \frac{10.60 \times 10^{-3}}{0.65 \times 0.18^2 \times 14.2} = 0.035 \leq \mu_l = 0.392 \Rightarrow A'_s = 0$$

$$\alpha = 1.25 \times (1 - \sqrt{1 - 2 \times 0.035}) = 0.044$$

$$Z = d \times (1 - 0.4\alpha) = 18 \times (1 - 0.4 \times 0.044) = 17.68$$

$$A_s = \frac{10.60 \times 10^{-3}}{17.68 \times 10^{-2} \times 348} = 1.72 \times 10^{-4} \text{m}^4 = 0.17 \text{cm}^2$$

**Current floor Type 01 :**

$$\mu_0 = \frac{11 \times 10^{-3}}{0.65 \times 0.18^2 \times 14.2} = 0.036 \leq \mu_l = 0.392 \Rightarrow A'_s = 0$$

$$\alpha = 1.25 \times (1 - \sqrt{1 - 2 \times 0.036}) = 0.045$$

$$Z = d \times (1 - 0.4\alpha) = 18 \times (1 - 0.4 \times 0.045) = 17.67$$

$$A_s = \frac{11 \times 10^{-3}}{17.67 \times 10^{-2} \times 348} = 1.78 \times 10^{-4} \text{m}^4 = 0.17 \text{cm}^2$$

**Current floor Type 02 :**

$$\mu_0 = \frac{5.85 \times 10^{-3}}{0.65 \times 0.18^2 \times 14.2} = 0.019 \leq \mu_1 = 0.392 \Rightarrow A'_s = 0$$

$$\alpha = 1.25 \times (1 - \sqrt{1 - 2 \times 0.019}) = 0.023$$

$$Z = d \times (1 - 0.4\alpha) = 18 \times (1 - 0.4 \times 0.023) = 17.83$$

$$A_s = \frac{5.85 \times 10^{-3}}{17.83 \times 10^{-2} \times 348} = 9.42 \times 10^{-4} \text{m}^4 = 0.94 \text{cm}^2$$

**Current floor Type 03 :**

$$\mu_0 = \frac{8.28 \times 10^{-3}}{0.65 \times 0.18^2 \times 14.2} = 0.027 \leq \mu_1 = 0.392 \Rightarrow A'_s = 0$$

$$\alpha = 1.25 \times (1 - \sqrt{1 - 2 \times 0.027}) = 0.034$$

$$Z = d \times (1 - 0.4\alpha) = 18 \times (1 - 0.4 \times 0.034) = 17.75$$

$$A_s = \frac{8.28 \times 10^{-3}}{17.75 \times 10^{-2} \times 348} = 1.34 \times 10^{-4} \text{m}^4 = 0.13 \text{cm}^2$$

**Tab III.20 : Calculate reinforcement for the supports**

Type	$\mu$	$\alpha$	Z	$A_s$	$A'_s$
1(Terrce floor)	0.035	0.044	17.68	0.17	0
1(current floor)	0.036	0.045	17.67	0.17	0
2(current floor)	0.019	0.023	17.83	0.94	0
3(current floor)	0.027	0.034	17.75	0.13	0

So we adopt :

**Tab III.21 : Floor reinforcement**

Type	$A_s$ support	$A_s$ Span
1(Terrce floor)	2HA10=1.57	3HA10=2.36
1(current floor)	2HA10=1.57	3HA10=2.36
2(current floor)	2HA10=1.57	3HA10=2.36
3(current floor)	2HA10=1.57	3HA10=2.36

**III.3.4.3 Non-fragility condition :**

$$A_{\min} \geq 0.23 \times b \times d \times \frac{f_{t28}}{f_e}$$

- **In span :**

$$A_{\min} = 0.23 \times 0.18 \times 0.65 \times \frac{2.1}{400} = 1.41 \text{cm}^2$$

$$\text{Type 1} \Rightarrow A_s = 2.36 \text{cm}^2 \geq A_{\min} = 1,41 \text{cm}^2 \dots\dots\dots \text{CV}$$

$$\text{Type 2} \Rightarrow A_s = 2.36 \text{cm}^2 \geq A_{\min} = 1,41 \text{cm}^2 \dots\dots\dots \text{CV}$$

$$\text{Type 3} \Rightarrow A_s = 2.36 \text{cm}^2 \geq A_{\min} = 1,41 \text{cm}^2 \dots\dots\dots \text{CV}$$

- **In supports :**

$$A_{\min} = 0.23 \times 0.18 \times 0.10 \times \frac{2.1}{400} = 0.22 \text{cm}^2$$

$$\text{Type 1} \Rightarrow A_s = 1.57 \text{cm}^2 \geq A_{\min} = 0.22 \text{cm}^2 \dots\dots\dots \text{CV}$$

$$\text{Type 2} \Rightarrow A_s = 1.57 \text{cm}^2 \geq A_{\min} = 0.22 \text{cm}^2 \dots\dots\dots \text{CV}$$

$$\text{Type 3} \Rightarrow A_s = 1.57 \text{cm}^2 \geq A_{\min} = 0.22 \text{cm}^2 \dots\dots\dots \text{CV}$$

**III.3.5 Transverse reinforcement:**

$$\emptyset \leq \min\left(\frac{h_t}{35}; \emptyset_l; \frac{b}{10}\right)$$

So :

$$\emptyset \leq \min\left(\frac{200}{35} = 5.71; 12; \frac{100}{10} = 10\right) = 5.71 \text{mm}$$

We adopt :  $\emptyset = 8 \text{mm}$

**III.3.6 Spacing of transverse reinforcements:**

- **Nodal zone:**

$$S_t \leq \min\left(\frac{h}{4}; 12\phi\right)$$

So :

$$S_t \leq \min\left(\frac{20}{4}; 12 \times 1.2\right)$$

We adopt :  $S_t = 5\text{cm}$

- **Currente zone:**

$$S_t \leq \min\left(\frac{h}{2}\right)$$

So :

$$S_t \leq \min\left(\frac{20}{2}\right) \leq 10\text{cm}$$

We adopt :  $S_t = 10\text{cm}$

**III.3.5 Verification at the SLS :**

- As cracking is not harmful (not very harmful).....CV
- The steel used is grade FeE400.....CV
- la section est rectangulaire (1x0,15).....CV
- Simple flexion.....CV

If the condition below is verified, limiting the stresses in the concrete will be unnecessary:

$$\alpha \leq \frac{\gamma-1}{2} + \frac{f_{c28}}{100} \text{ With } \gamma = \frac{M_u}{M_{ser}}$$

**Type 01 :**

**In span :**  $\alpha = 0.040$

$$\gamma = \frac{9.45}{6.88} = 1.37$$

$$\alpha = 0.040 \leq \frac{1.37 - 1}{2} + \frac{25}{100} = 0.44 \dots CV$$

**In support :**  $\alpha = 0.044$

Terrace floor :

$$\gamma = \frac{10.60}{7.72} = 1.37$$

$$\alpha = 0.044 \leq \frac{1.37 - 1}{2} + \frac{25}{100} = 0.44 \dots CV$$

Current floor :  $\alpha = 0.045$

$$\gamma = \frac{11}{7.95} = 1.38$$

$$\alpha = 0.045 \leq \frac{1.38 - 1}{2} + \frac{25}{100} = 0.44 \dots CV$$

**Type 02 :**

**In span :**  $\alpha = 0.023$

$$\gamma = \frac{5.84}{4.22} = 1.38$$

$$\alpha = 0.023 \leq \frac{1.38 - 1}{2} + \frac{25}{100} = 0.44 \dots CV$$

**In support :**  $\alpha = 0.023$

$$\gamma = \frac{5.85}{4.23} = 1.38$$

$$\alpha = 0.023 \leq \frac{1.38 - 1}{2} + \frac{25}{100} = 0.44 \dots CV$$

Type 03 :

**In span :**  $\alpha = 0.031$

$$\gamma = \frac{7.57}{5.47} = 1.38$$

$$\alpha = 0.031 \leq \frac{1.38 - 1}{2} + \frac{25}{100} = 0.44 \dots CV$$

**In support :  $\alpha = 0.034$**

$$\gamma = \frac{8.28}{5.98} = 1.38$$

$$\alpha = 0.034 \leq \frac{1.38 - 1}{2} + \frac{25}{100} = 0.44 \dots CV$$

Verification at the SLS is not necessary.

### III.3.8 Verification of the shear force (CBA93 A.5.1):

It is necessary that :

$$\tau_u = \frac{v_u}{b \times d} \leq \bar{\tau}_u$$

We have according to CBA93 (A.5.1.2.1.1):

$$\bar{\tau}_u = \min \left\{ 0.20 \frac{f_{c28}}{\gamma_b}; 5 \text{ Mpa} \right\} = \min \{ 3.33 \text{ Mpa}; 5 \text{ Mpa} \} = 3.33 \text{ Mpa}$$

**Tab III.22 : Checking the shear force**

Type	$v_u$	$\tau_u$ (Mpa)	$\bar{\tau}_u$ (Mpa)	$\tau_u \leq \bar{\tau}_u$
<b>1(Terrce floor)</b>	15.36	0.13	3.33	cv
<b>1(current floor)</b>	15.95	0.13	3.33	cv
<b>2(current floor)</b>	11.95	0.10	3.33	cv
<b>3(current floor)</b>	13.92	0.11	3.33	cv

### III.3.9 Verification of the deflection (CBA93 B.6.8.4.2.4):

- $\frac{h}{3} \geq \frac{1}{22.5} \Rightarrow \frac{20}{3} = 0.06 \geq \frac{1}{22.5} = 0.044 \dots CV$
- $\frac{A_s}{b \times d} \leq \frac{3.6}{f_e} \Rightarrow \frac{2.36}{65 \times 18} = 0.002 \leq \frac{3.6}{400} = 0.009 \dots CV$
- $\frac{h}{L} \geq \frac{1}{15} \left( \frac{M_t}{M_0} \right)$

$$\text{Type 01(Terrece)} \Rightarrow \frac{h}{L} = \frac{20}{440} = 0.04 \geq \frac{1}{15} \left( \frac{M_t}{M_0} \right) = \frac{1}{15} \left( \frac{6.88}{10.02} \right) = 0.04 \dots \dots \dots \text{cv}$$

$$\text{Type 01 (Current)} \Rightarrow \frac{h}{L} = \frac{20}{440} = 0.04 \geq \frac{1}{15} \left( \frac{M_t}{M_0} \right) = \frac{1}{15} \left( \frac{7.09}{10.32} \right) = 0.04 \dots \dots \dots \text{cv}$$

$$\text{Type 02 (Current)} \Rightarrow \frac{h}{L} = \frac{20}{385} = 0.05 \geq \frac{1}{15} \left( \frac{M_t}{M_0} \right) = \frac{1}{15} \left( \frac{4.22}{8.18} \right) = 0.03 \dots \dots \dots \text{cv}$$

$$\text{Type 03 (Current)} \Rightarrow \frac{h}{L} = \frac{20}{385} = 0.05 \geq \frac{1}{15} \left( \frac{M_t}{M_0} \right) = \frac{1}{15} \left( \frac{5.47}{7.91} \right) = 0.04 \dots \dots \dots \text{cv}$$

All the conditions are verified, therefore:

**Checking the deflection is not necessary**

**III.3.10 Reinforcement detailing :**

In our case, the most heavily loaded floor is the type 2 floor, so only one reinforcement detailing schema is required.

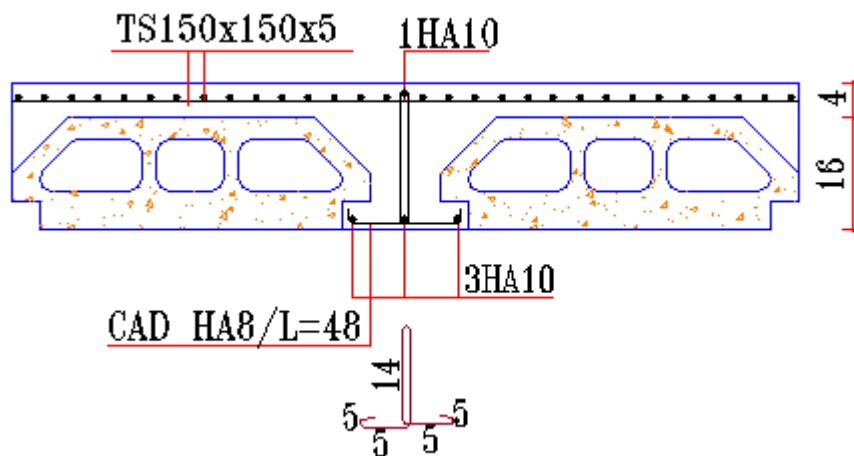

Figure III.24 : Reinforcement of beams on span (type 2)

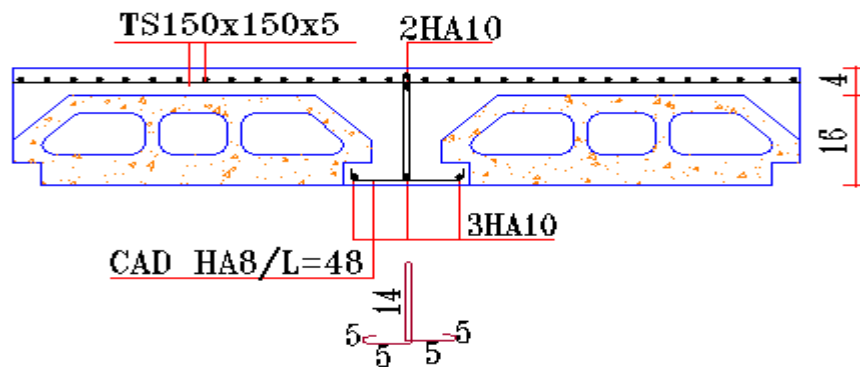

Figure III.25 : Reinforcement of beams on support (type 2)

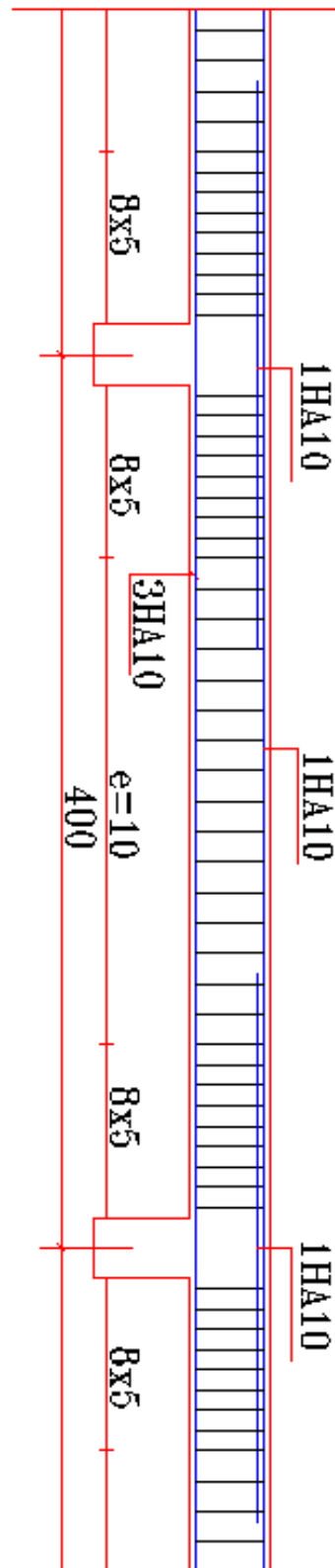

Figure III26 : reinforcement of the beam

### III.4. The Balconies :

#### III.4.1. Definition :

In the use of residential buildings, the balcony is a decorative element, the balconies are anchored to the beams and are solicited by simple bending. The types to study is represented by the figures below :

#### III.4.2. Primaire slab case resting on two dimensions :

##### III.4.2.1 Method of calculation :

- We apply the theory of breaking lines
- The calculation is done on a 1m wide band of a rectangular working with simple bending due to :
  - **G** : dead loads.
  - **Q** : live loads.
  - **P** : load of external walls and parapet wall.

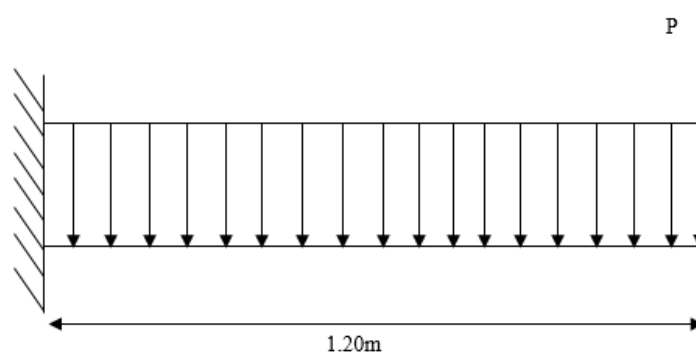

Figure III.27: Static diagram of the balcony

Table III.4.2.1. Evaluation of current floor balcony loads :

Description	Weight (Kg/m <sup>3</sup> )	Thickness (m)	□ G'' (Kn/m <sup>3</sup> )
Tiling	2200	0.02	44
Laying mortar	2000	0.03	60
Sandbed	1700	0.02	34
Hollow slab	2500	0.14	350
Plaster coating	1400	0.02	28
<b>Dead load (G)</b>	-	-	<b>5.16</b>
<b>Live load (Q)</b>	-	-	<b>3.5</b>

- Dead load :  $G = 5.16 \times 1\text{m} = 5.16 \text{ KN/m.l} \rightarrow 0.516 \text{ T/m.l}$
- Live load :  $Q = 3.5 \times 1\text{m} = 3.5 \text{ KN/m.l} \rightarrow 0.35 \text{ T/m.l}$
- load of external walls  $P : 1.3 \times 1 \times 1 = 1.3 \text{ KN/m.l} \rightarrow 0.13 \text{ T/m.l}$

**III4.2.2. Combination of loads :**➤ U.L.S :

$$q_u = 1.35 \times G + 1.5 \times Q = 1.35 \times 5.16 + 1.5 \times 3.5 = 12.216 \text{ KN/m.l} \rightarrow 1.2216 \text{ T/m.l}$$

$$p_u = 1.35 \times P = 1.35 \times 1.3 = 1.755 \text{ kN/m.l} \rightarrow 0.1755 \text{ T/m.l}$$

➤ S.L.S :

$$q_s = G + Q = 5.16 + 3.5 = 8.66 \text{ KN/m.l} \rightarrow 0.866 \text{ T/m.l}$$

$$p_s = P = 1.35 \text{ KN/m.l} \rightarrow 0.135 \text{ T/m.l}$$

## ▪ Bending moment :

➤ U.L.S :

$$M_u = \frac{q_u \times L^2}{2} - p_u \times L = \frac{12.216 \times 1.2^2}{2} - 1.755 \times 1.2$$

$$M_u = 6.698 \text{ KN.m} \rightarrow 0.6698 \text{ T.m}$$

➤ S.L.S :

$$M_s = \frac{q_s \times L^2}{2} - p_s \times L = \frac{8.66 \times 1.2^2}{2} - 1.3 \times 1.2$$

$$M_s = 7.795 \text{ KN.m} \rightarrow 0.7795 \text{ T.m}$$

## ▪ Effort tranchant :

$$t_u = q_u \times L + p_u = 16.414 \text{ KN.m} \rightarrow 1.6414 \text{ T.m}$$

**III4.2.3. Determination of reinforcement :**

Nous considérons le balcon comme un faisceau de console soumis à une simple

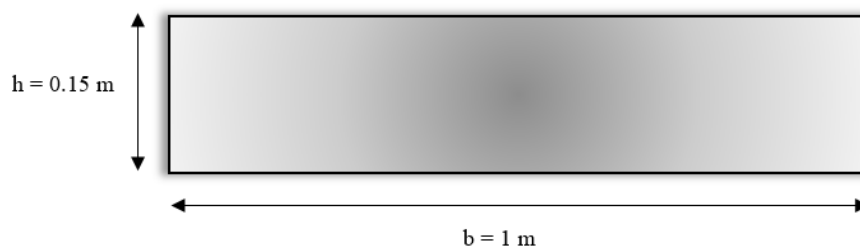

flexion and the calculation is done by a strip of 1 ml.

➤ U.L.S :

- Longitudinal reinforcement :

$$f_{bc} = \frac{0.8 \times f_{c28}}{\gamma_s} = 14.2 \text{ MPA}$$

$$d = 0.9 \times h = 0.9 \times 0.15 = 0.135 \text{ m}$$

$$\mu_u = \frac{M_u}{b \cdot d^2 \cdot f_{bc}} = \frac{6.698 \times 10^{-3}}{1 \times 0.135^2 \times 14.2} = 0.0258 < \mu_1 = 0.391$$

$$\alpha = 1.25 (1 - \sqrt{1 - 2\mu_u}) = 1.25 (1 - \sqrt{1 - 2 \times 0.0258}) = 0.0327$$

$$\beta = 0.8 \times \alpha = 0.8 \times 0.0327 = 0.026$$

$$A_s = \beta \times b \times d \times \frac{f_{bc}}{\sigma_s} = 0.026 \times 1 \times 0.135 \times \frac{14.2}{348} = 1.432 \times 10^{-4} \text{ m}^2$$

$$A_s = 1.432 \text{ cm}^2 \quad \text{we adopt 5HA10} = 3.93 \text{ cm}^2$$

$$\text{With : } S_t = \frac{100}{5} = 20 \text{ cm}$$

- Distribution reinforcement :

According to the article of B.A.8.2.42 of **BAEL 91**

$$A_r = \frac{A_s}{5} = \frac{3.93}{5} = 0.786 \quad \text{we take 2HA10} = 1.57$$

With a spacing of the reinforcements : **BAEL 91 A.8.2.42**

$$S_t = \min \{3h_t; 33 \text{ cm}\} = \min \{3 \times 15 \text{ cm}; 33 \text{ cm}\}$$

$$\text{We take : } S_t = 33 \text{ cm}$$

- Condition of non-fragility : (**Art4.2.1/BAEL91**)

$$A_{s_{\min}} = \frac{0.23 \cdot b \cdot d \cdot f_{t28}}{f_e} = \frac{0.28 \times 1 \times 0.135 \times 2.1}{400} = 1.63 \times 10^{-4} \text{ m}^2$$

$$A_{s_{\min}} = 1.63 \text{ cm}^2$$

$$A_s = 3.93 \text{ cm}^2 > A_{s_{\min}} = 1.63 \text{ cm}^2 \dots\dots\dots \text{CV}$$

- Verification of shear stress :

$$\tau_u \leq \bar{\tau}_u$$

$$\diamond \bar{\tau}_u = \min \left\{ 0.15 \times \frac{f_{c28}}{\gamma_b} ; 4 \text{ MPa} \right\} = \min \{ 2.5 \text{ MPa} ; 4 \text{ MPa} \} = 2.5 \text{ MPa}$$

$$\diamond \bar{\tau}_u = \frac{t_u}{b \times d} = \frac{16.414 \times 10^{-3}}{1 \times 0.135} = 0.121 \text{ MPa}$$

$$\tau_u = 0.121 \text{ MPa} < \bar{\tau}_u = 2.5 \text{ MPa} \dots\dots\dots \text{CV}$$

So : There is no need to provide transverse reinforcements.

➤ S.L.S :

The calculation is done according to the rules of **CBA 93 and BAEL 91 modified 2003**, cracking is considered to be detrimental.

▪ Neutral axis position :

$$by^2 + 30(As + As')y - 30d(As + As') = 0$$

$$As' = 0$$

$$by^2 + 30As \times y - 30d \times As = 0$$

$$100y^2 + (30 \times 3.93)y - 30 \times 13.5 \times 3.93 = 0$$

$$100y^2 + 117.9y - 1591.65 = 0$$

$$\Delta = b^2 - 4ac = (117.9^2) - 4(100 \times 1591.65)$$

$$\Delta = -622759.59 \quad ; \quad \sqrt{\Delta} = 789.151$$

$$\begin{cases} y_1 = \frac{-b - \sqrt{\Delta}}{2a} = \frac{-117.9 - 789.151}{2 \times 100} = -4.54 \\ y_2 = \frac{-b + \sqrt{\Delta}}{2a} = \frac{-117.9 + 789.151}{2 \times 100} = 3.36 \end{cases}$$

$$\text{So : } y_{ser} = 3.36$$

▪ The moment of inertia :

$$I = \frac{b}{3} \times y^3 + 15As(d - y)^2$$

$$I = \frac{100}{3} \times (3.36^3) + 15 \times 3.93 \times (13.5 - 3.36)^2$$

$$I = 7325.65 \text{ cm}^4$$

- Determination of the angular coefficient :

$$K = \frac{M_{ser}}{I} = \frac{7.795 \times 10^2}{7325.65} = 0.106$$

- Verification of constraints :

- ❖ Maximum concrete compression constraint :

$$\sigma_{bc} \leq \overline{\sigma}_{bc}$$

$$\overline{\sigma}_{bc} = 0.6 \times f_{c28} = 0.6 \times 25 = 15 \text{ MPa}$$

$$\sigma_{bc} = K \times y = 0.106 \times 3.36 = 0.356 \text{ MPA}$$

$$\sigma_{bc} = 0.356 \text{ MPA} < \overline{\sigma}_{bc} = 15 \text{ MPA} \dots\dots\dots \text{CV}$$

- ❖ Maximum steel traction stress :

$$\overline{\sigma}_s = \min \left\{ \frac{2}{3} f_e ; 110 \sqrt{\eta \times f_{tj}} \right\} = \min \left\{ \frac{2}{3} \times 400 ; 110 \sqrt{1.6 \times 2.1} \right\}$$

$$\overline{\sigma}_s = \min\{266.66 ; 201.63\}$$

$$\overline{\sigma}_s = 201.63 \text{ MPA}$$

$$\sigma_s = 15 \times k(d - y) = 15 \times 0.106(13.5 + 3.36)$$

$$\sigma_s = 26.80 \text{ MPA}$$

$$\sigma_s = 26.80 \text{ MPA} < \overline{\sigma}_s = 201.63 \text{ MPA} \dots\dots\dots \text{CV}$$

- ❖ Arrow verification : **BAEL 91. (Art B.7.5.1)**

$$\frac{h}{L} \geq \frac{1}{16} \Rightarrow \frac{15}{120} \geq \frac{1}{16} \Rightarrow 0.125 > 0.062 \dots\dots\dots \text{CV}$$

$$\frac{h}{L} \geq \frac{Mt}{10M0} \Rightarrow \frac{15}{120} \geq \frac{0.75}{10} \Rightarrow 0.125 > 0.075 \dots\dots\dots \text{CV}$$

$$\frac{A}{b \times d} < \frac{4.2}{f_e} \Rightarrow \frac{2.51}{100 \times 13.5} < \frac{4.2}{400} \Rightarrow 1.859 < 0.011 \dots\dots\dots \text{CV}$$

III.4.2.4. Shema of reinforcement in balconies :

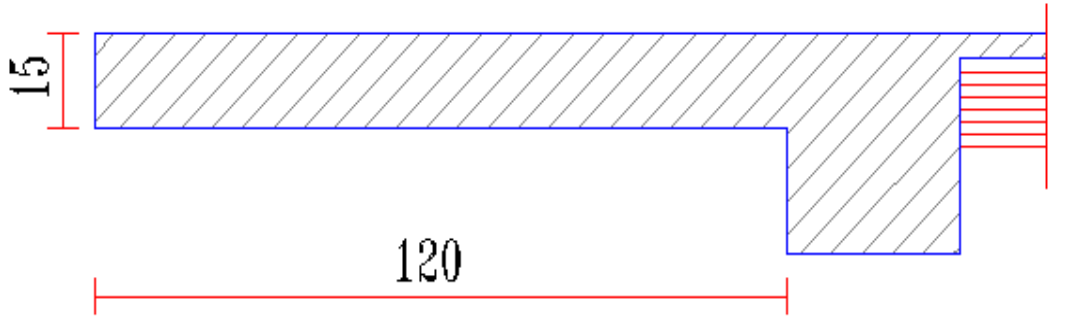

# Ferrailage Balcon

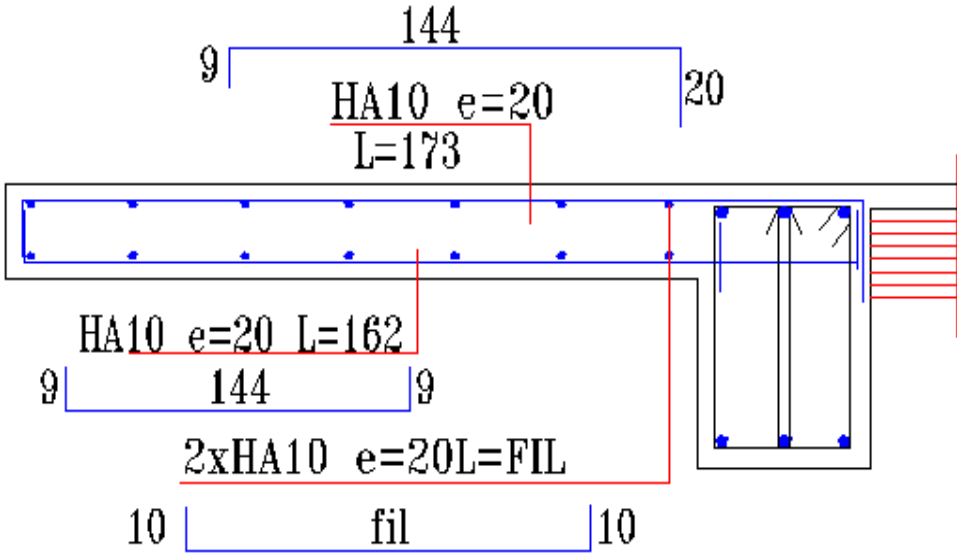

Figure III.28 : Shema of reinforcement in balconies

### III.5. Stairs:

#### III.5.1 Definition:

A staircase is a succession of steps allowing the passage from one level to another, it can be in reinforced concrete, steel or wood.

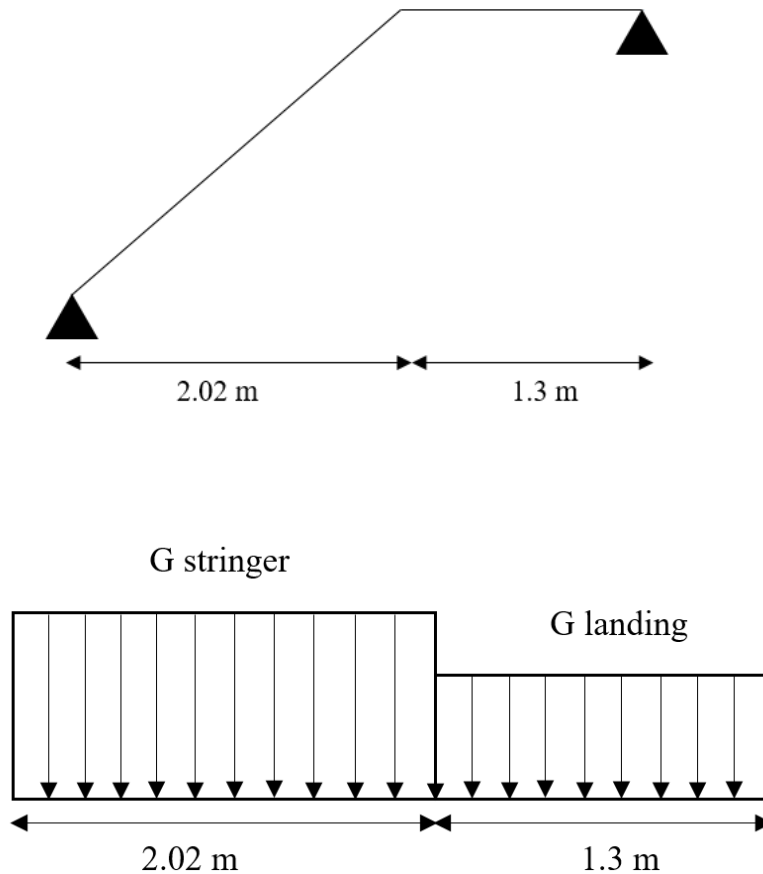

Figure III.29: Schema bench

#### III.5.2. Evaluation of the loads :

##### 1.1.1. Staircase stringer :

- Own weight :  $25 \times 0.15 / \cos 32.51^\circ \times 1 = 4.446 \text{ KN/m}$
- Weight of the steps :  $0.17 \times 22 / 2 \times 1 = 1.87 \text{ KN/m}$
- Coating :  $0.50 \times 1 = 0.50 \text{ KN/m}$
- Plaster coating (2 cm) :  $0.02 \times 10 / \cos 32.51^\circ \times 1 = 0.237 \text{ KN/m}$
- Railing :  $= 0.42 \text{ KN/m}$

$$G_1 = 7.47 \text{ KN/m} \Rightarrow 0.747 \text{ T/m}$$

1.1.2. Landing :

- Own weight :  $25 \times 0.15 \times 1 = 3.75 \text{ KN/m}$
- Coating :  $0.50 \times 1 = 0.50 \text{ NN/m}$
- Plaster coating :  $0.02 \times 10 \times 1 = 0.20 \text{ KN/m}$

$$G_2 = 4.45 \text{ KN/m} \Rightarrow 0.445 \text{ T/m}$$

$$\text{Live load : } Q = 250 \text{ KG/m}^2 \times 1 = 2.5 \text{ KN/m} \Rightarrow 0.25 \text{ T/m}$$

G equivalent

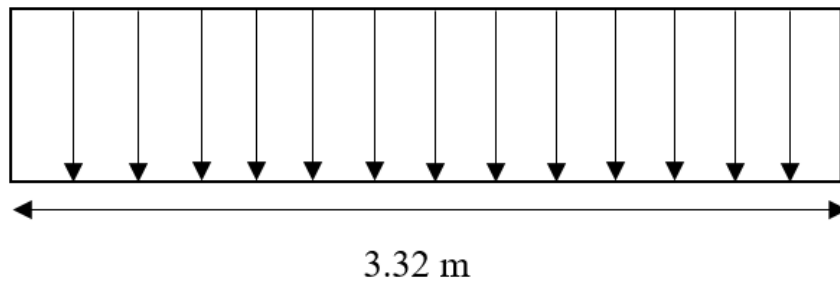

**III.5.3. Combinations of action :**

	stringer	Landing
ULS	$q_{u1} = 1.35 \times G_1 + 1.5 \times Q$ $= (1.35 \times 7.47) + (1.5 \times 2.5)$ $= 14.19 \text{ KN/m}$	$q_{u2} = 1.35 \times G_2 + 1.5 \times Q$ $= (1.35 \times 4.45) + (1.5 \times 2.5)$ $= 9.75 \text{ KN/m}$
SLS	$q_{ser1} = G_1 + Q$ $= 7.47 + 2.5$ $= 9.97 \text{ KN/m}$	$q_{ser2} = G_2 + Q$ $= 4.45 + 2.5$ $= 6.95 \text{ KN/m}$

$q_{u1}$  and  $q_{u2}$  are not close : the equivalent load :  $q_e = \frac{\sum q_i l_i}{\sum l_i}$

$$q_{eu} = \frac{(14.19 \times 2.02) + (9.75 \times 1.30)}{(2.02 + 1.30)} = 12.45 \text{ KN/m} \Rightarrow 1.245 \text{ T/m}$$

$$q_{eser} = \frac{(9.97 \times 2.02) + (6.95 \times 1.30)}{(2.02 + 1.30)} = 8.78 \text{ KN/m} \Rightarrow 0.878 \text{ T/m}$$

$$M_o = \frac{q_e \times l^2}{8}$$

$$T = \frac{q_e \times l}{2}$$

ULS	$M_{ou} = \frac{q_{eu} \times l^2}{8} = \frac{12.45 \times 3.32^2}{8} = 17.15 \text{ KN/m}$	
	Midspan (t)	$M_{tu} = 0.8 \times M_{ou} = 0.8 \times 17.15 = 13.72 \text{ KN/m}$
	Support (a)	$M_{au} = 0.4 \times M_{ou} = 0.4 \times 17.15 = 6.86 \text{ KN/m}$
	$T = \frac{q_{eu} \times l}{2} = \frac{12.45 \times 3.32}{2} = 20.66 \text{ KN/m}$	
SLS	$M_{oser} = \frac{q_{esre} \times l^2}{8} = \frac{8.78 \times 3.32^2}{8} = 12.09 \text{ KN/m}$	
	Midspan (t)	$M_{tser} = 0.8 \times M_{oser} = 0.8 \times 12.09$ $= 9.67 \text{ KN/m}$
	Support (a)	$M_{aser} = 0.4 \times M_{oser} = 0.4 \times 12.09$ $= 4.83 \text{ KN/m}$

#### □.5.4. Calculation of reinforcement :

The calculation is made in increments of 1 m in width.

$$f_{bc} = 14.2 \text{ MPA} ; f_{t28} = 2.1 ; \sigma_s = 348 \text{ MPA} ; d = 0.9 \times h = 0.9 \times 0.17 = 0.153 \text{ m}$$

$$\mu = \frac{M_{ut}}{b \times d \times f_{bc}}$$

$$\alpha = 1.25 \times (1 - \sqrt{1 - (2 \times \mu)})$$

$$\beta = 0.8 \times \alpha$$

$$A_s = \beta \times b \times d \times \frac{f_{bc}}{\sigma_s}$$

$$A_{smin} = \geq \max \left\{ \frac{b \times h}{1000}; 0.23 \times b \times d \times \frac{f_{t28}}{f_e} \right\}$$

	<b>M<sub>u</sub></b> <b>(KN.m)</b>	<b>b</b> <b>(cm)</b>	<b>d</b> <b>(cm)</b>	<b>μ</b>	<b>α</b>	<b>β</b>	<b>A<sub>s</sub></b> <b>(cm<sup>2</sup>)</b>	<b>A<sub>smin</sub></b> <b>(cm<sup>2</sup>)</b>	<b>Wetake</b> <b>(cm<sup>2</sup>)</b>
<b>Span</b>	13.72	100	15.3	0.041	0.0523	0.0418	2.55	1.84	4HA10 =3.14
<b>support</b>	6.86	100	15.3	0.020	0.0275	0.022	1.37	1.84	4HA10 = 3.14

**III.5.5. Verification SLS :**

As cracking is not very detrimental, Crack control is not necessary, and as the section is rectangular, subjected to simple bending with steel type FeE400, It therefore remains to be verified :  $\sigma_{bc} \leq 0.6f_{c28} = 0.6 \times 25 = 15$  MPA

This check may not be carried out if :  $\alpha \leq \frac{\gamma-1}{2} + \frac{f_{c28}}{100}$  with  $\gamma = \frac{M_u}{M_{ser}}$

$$\gamma = \frac{17.15}{12.09} = 1.41 ; \quad \alpha = 0.445$$

<b>In span</b>	$\alpha = 0.0523$	$0.0523 < 0.455 \dots CV$
<b>In support</b>	$\alpha = 0.0275$	$0.0275 < 0.455 \dots CV$

So the SLS check is not necessary.

- Verification of the shaft :

$$\frac{h}{L} \geq \frac{1}{16} \Rightarrow \frac{0.15}{3.32} = 0.0451 < \frac{1}{16} = 0.0625 \dots CNV$$

$$\frac{h}{L} \geq \frac{M_t}{10M_o} \Rightarrow \frac{0.15}{3.32} = 0.0451 < \frac{0.8M_o}{10M_o} = 0.08 \dots CNV$$

$$\frac{A_s}{bd} \leq \frac{4.2}{f_e} \Rightarrow \frac{3.14}{100 \times 15.3} = 2.05 \times 10^{-3} < \frac{4.2}{400} = 0.0105 \dots\dots\dots CV$$

$$L = 3.32 \leq 8 \text{ m} \dots\dots\dots CV$$

Since condition (1) and (3) are not verified, therefore the condition must be verified:

$$f = \frac{5 \times q_{ser} \times L^4}{348 \times EI}$$

$$I = \frac{b \times h^3}{12} = \frac{100 \times 15^3}{12} = 28125 \text{ cm}^4$$

$$E = 11000 \sqrt[3]{f_{c28}} = 32164.195 \text{ MPA}$$

$$f = \left( \frac{5 \times 878 \times 332^4}{348 \times 32164.195 \times 28125} \right) \times 10^{-3} = 0.1694$$

$$f_{adm} = 0.5 + \frac{L}{1000} = 0.5 + \frac{332}{1000} = 0.832$$

$$f = 0.1694 < f_{adm} = 0.832 \dots\dots\dots CV$$

#### □.5.6.Reinforcements distribution :

$$\text{In span: } A_t = \frac{A_s}{4} = \frac{3.14}{4} = 0.78 \quad \text{we take : } 3HA8 = 1.51 \text{ cm}^2$$

$$\text{In support: } A_s = \frac{A_s}{4} = \frac{1.84}{4} = 0.46 \quad \text{we take : } 4HA6 = 1.13 \text{ cm}^2$$

#### III.5.7Reinforcement Spacing :

➤ Spacing of the main reinforcement :

$$s_t \leq \min\{3h ; 33 \text{ cm}\}$$

$$s_t \leq \min\{(3 \times 17) = 51 \text{ cm} ; 33 \text{ cm}\}$$

$$s_t \leq 33 \text{ cm}$$

$$\text{In span: } s_t = \frac{100}{4} = 25 < 33 \text{ cm} \dots\dots\dots CV$$

$$\text{In support: } s_t = \frac{100}{4} = 25 < 33 \text{ cm} \dots\dots\dots CV$$

➤ Spacing of distribution reinforcement :

$$s_t \leq \min\{4h ; 45 \text{ cm}\}$$

$$s_t \leq \min\{(4 \times 17) = 68 ; 45 \text{ cm}\}$$

$$s_t \leq 45 \text{ cm}$$

$$\text{In span : } s_t = \frac{100}{3} = 33.33 < 45 \text{ cm} \dots\dots\dots\text{CV}$$

$$\text{In support : } s_t = \frac{100}{4} = 25 < 45 \text{ cm} \dots\dots\dots\text{CV}$$

### III.5.8.Verification of shear force:

$$\text{We must check : } \tau_u = \frac{T_u}{bd} \leq \overline{\tau}_u$$

$$\overline{\tau}_u = \min\left(\frac{0.2 \times f_{c28}}{\gamma_b} ; 5\right) = \min(3.33 ; 5)$$

$$\overline{\tau}_u = 3.33 \text{ MPA}$$

$$\tau_u = \frac{20.66 \times 10^3}{1000 \times 153} = 0.135 < 3.33 \dots\dots\dots\text{CV}$$

III.5.9. Stair reinforcement diagram :

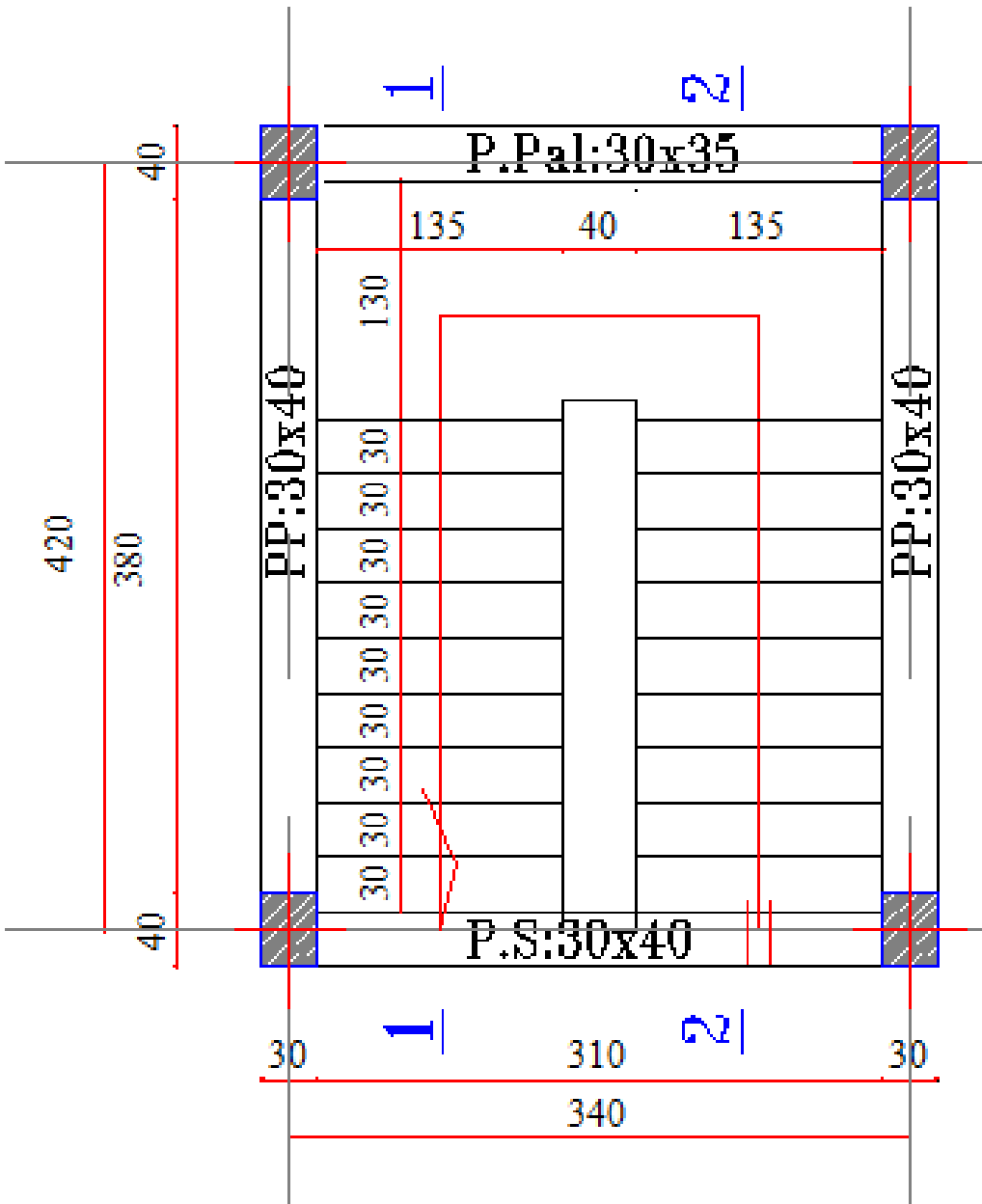
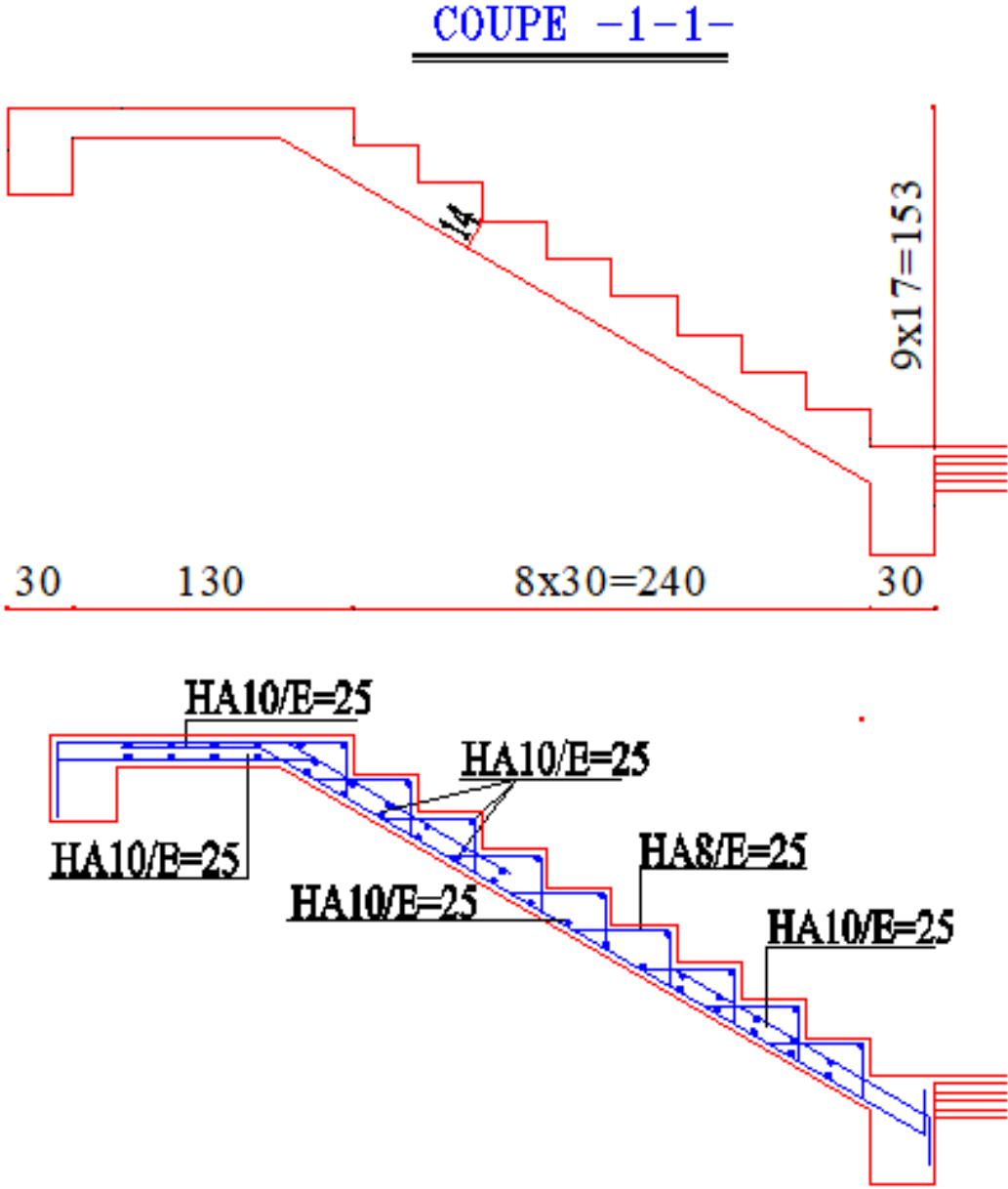

Figure III.30. Reinforcement diagram of the stair cutting 1-1



### III.6. Study of the platform screen beam :

The calculation is made by the simple bending of a beam that is simply supported and uniformly loaded, the charges are :

- ✓ Its own weight.
- ✓ Weight of masonry.
- ✓ Reaction from the Bearing and Bench.

$$L = 3.10 \text{ m} ; h = 35 \text{ cm} ; b = 30 \text{ cm}$$

According to the **RPA 99 / V 2003**

$$b = 30 > 20 \dots\dots\dots \text{CV}$$

$$h = 35 > 30 \dots\dots\dots \text{CV}$$

$$\frac{h}{b} = \frac{35}{30} = 1.16 < 4 \dots\dots\dots \text{CV}$$

#### III.6.1. Load evaluation :

- Own weight of the platform screen beam :

$$G_{pp} = h \times b \times \gamma = 0.35 \times 0.30 \times 25 = 2.62 \text{ KN/m}$$

- Own weight of the masonry wall :

$$G_{wall} = \left( \frac{h_e}{2} - h_p \right) \times G = \left( \frac{3.06}{2} - 0.35 \right) \times 3.41 = 4.02 \text{ KN/m}$$

$$G = G_{pp} + G_{wall} = 6.64 \text{ KN/m}$$

- Reactions :

$$R = \frac{q \times l}{2}$$

U.L.S	S.L.S
$R_u = 20.66 \text{ KN/m}$	$R_{ser} = 14.57 \text{ KN/m}$

**III.6.2. Load on the landing beam :**

$$\text{U.L.S : } q_u = 1.35 \times G + R_u = 8.964 + 20.66 = 29.62 \text{ KN/m}$$

$$\text{S.L.S : } q_{\text{ser}} = G + R_{\text{ser}} = 6.64 + 14.57 = 21.21 \text{ KN/m}$$

**Table III24 : Moments and shear force in the landing beam :**

	Formulas	U.L.S $q_u = 29.62$	S.L.S $q_{\text{ser}} = 21.21$
<b>Isostatic moment (KN.m)</b>	$M_o = \frac{q_{\text{eu}} \times l^2}{8}$	35.58	25.47
<b>Moment on Supports (KN.m)</b>	$M_a = 0.4 \times M_{\text{ou}}$	14.23	10.18
<b>Span Moment (KN.m)</b>	$M_t = 0.8 \times M_{\text{ou}}$	28.46	20.37
<b>Shear force (KN)</b>	$T = \frac{q \times l}{2}$	45.91	

**□.6.3. Reinforcement Design at the Strength ULS :**

$$b = 30 \text{ cm ; } h = 35 \text{ cm ; } d = 0.9 \times 0.35 = 0.315 \text{ m}$$

✓ Longitudinal reinforcement :

	$\mu$	A	$\beta_u$	$A_s$ ( $\text{cm}^2$ )	We take ( $\text{cm}^2$ )
<b>Span « t »</b>	0.067 $0.067 < 0.391$ $A'_s = 0$	0.086	0.068	2.60	6HA10 = 4.71
<b>Supports « a »</b>	0.033 $0.033 < 0.391$ $A'_s = 0$	0.041	0.033	1.26	2HA10 = 1.57

## III.6.3. Condition of non-fragility : BAEL 91 (art A.4.2.1)

$$A_{\min} = 0.23 \times b \times d \times \frac{f_{t28}}{f_e}$$

<b>In span</b>	$A_{\min} = 1.14 < 4.71 \dots \dots \dots CV$
<b>In supports</b>	$A_{\min} = 1.14 < 1.57 \dots \dots \dots CV$

❖ Transverse reinforcement :

$$\varnothing_t \leq \min \left\{ \frac{h}{35} ; \frac{b}{10} ; \varnothing_1 \right\}$$

$$\varnothing_t \leq \min \left\{ \frac{350}{35} ; \frac{300}{10} ; 10\text{mm} \right\} = \min \{ 10\text{mm} ; 30\text{mm} ; 10\text{mm} \}$$

$$\varnothing_t \leq 10 \text{ mm}$$

Therefore :

$$\varnothing_1 = 8 \text{ mm}$$

$$A_t = \frac{A_1}{4}$$

In span :

$$A_t = \frac{1.57}{4} = 0.392 \text{ cm}^2$$

We take : 4HA8 = 2.01 cm<sup>2</sup>

In support :

$$A_t = \frac{3.14}{4} = 0.785 \text{ cm}^2$$

We take : 4HA8 = 2.01 cm<sup>2</sup>

## 2.5. Verification S.L.S :

$$\alpha \leq \frac{\gamma-1}{2} + \frac{f_{c28}}{100} \text{ With } \gamma = \frac{M_u}{M_{ser}}$$

**In span :**

$$\gamma = \frac{28.46}{20.37} = 1.397$$

$$\alpha = 0.084$$

$$0.084 < \frac{1.397-1}{2} + \frac{25}{100} = 0.448 \dots \text{CV}$$

**In support :**

$$\gamma = \frac{14.23}{10.18} = 1.397$$

$$\alpha = 0.041$$

$$0.041 < \frac{1.397-1}{2} + \frac{25}{100} = 0.448 \dots \text{CV}$$

So the SLS check is not necessary.

- Verification of the shaft :

$$\frac{h}{L} \geq \frac{1}{16} \Rightarrow \frac{0.35}{3.10} = 0.11 > \frac{1}{16} = 0.0625 \dots \text{CV}$$

$$\frac{h}{L} \geq \frac{M_{ts}}{10M_o} \Rightarrow \frac{0.35}{3.10} = 0.11 > \frac{20.37}{10 \times 25.47} = 0.079 \dots \text{CV}$$

$$\frac{A_s}{bd} \leq \frac{4.2}{f_e} \Rightarrow \frac{3.14}{30 \times 31.5} = 3.32 \times 10^{-3} < \frac{4.2}{400} = 0.0105 \dots \text{CV}$$

$$L = 3.10 \leq 8 \text{ m} \dots \text{CV}$$

### III.6.4. Verification of shear force :

- Concrete Shear Verification :

$$\tau_u = \frac{T_u}{bd} \leq \overline{\tau_u}$$

$$\tau_u = \frac{49.91 \times 10}{30 \times 31.5} = 0.485 \text{ MPA} < \overline{\tau_u} = 2.67 \text{ MPA} \dots \text{CV}$$

- Verification of areas of application of forces :

➤ Edge support :

-Verification of longitudinal reinforcement :

$$A_s = 3.14 \text{ cm}^2 \geq \frac{T_u + H_u}{\frac{f_e}{\gamma_s}} = \frac{45.91 \times 10}{\frac{400}{1.15}} = 1.31 \text{ cm}^2$$

$$3.14 \text{ cm}^2 > 1.31 \text{ cm}^2 \dots\dots\dots \text{CV}$$

### III.6.5. Calculates the torsional of the platform screen beam :

$$T_u = \frac{V \times b}{2} = \frac{57.91 \times 0.3}{2} = 6.886 \text{ KN.m}$$

❖ Torsional stress calculation :

$$\tau_{uT} = \frac{T_u}{2 \times \Omega \times e}$$

$$e = \frac{h}{6} = \frac{35}{6} = 5.83 \text{ cm}$$

$$\Omega = (b - e) \times (h - e) = (30 - 5.83) \times (35 - 5.83) = 705.04 \text{ cm}^2$$

$$\tau_{uT} = \frac{6.886 \times 10^{-3}}{2 \times 705.04 \times 5.83 \times 10^{-6}} = 0.838 \text{ MPa}$$

e : Hollow section thickness.

$\Omega$  : Contour area drawn halfway through the walls.

❖ Calculate the shear stress :

$$T_{cis} = \frac{T_u}{b \times d} = \frac{45.90 \times 10^3}{30 \times 31.5 \times 10^2} = 0.486 \text{ MPa}$$

❖ Torsional and bending strength :

$$\tau_{uT}^2 + \tau_{uT}^2 \leq \overline{\tau_u^2}$$

$$0.838^2 + 0.486^2 \leq 2.67^2$$

$$0.938 \leq 7.13 \dots\dots\dots \text{CV}$$

❖ The necessary reinforcements of torsion :

- Longitudinal reinforcement :

$$A_1 = \frac{U \times T_u}{2 \times \Omega \times \sigma_s}$$

$$U = ((b - e) \times (h - e)) \times 2 = ((30 - 5.83) \times (35 - 5.83)) \times 2 = 106.63 \text{ cm}^2$$

$$A_1 = \frac{6.886 \times 10^3 \times 106.63}{2 \times 705.04 \times 348} = 1.496 \text{ cm}^2$$

We take : 2HA10 = 1.57 cm<sup>2</sup>

- Transverse reinforcement :

$$A_t = \frac{T_u \times S_t}{2 \times \Omega \times \sigma_s}$$

$$S_t \leq \min\{0.9 \times d ; 40 \text{ cm}\} = \min\{28.35 \text{ cm} ; 40 \text{ cm}\} = 28.35 \text{ cm}$$

$$S_t = 25 \text{ cm}$$

$$A_t = \frac{6.886 \times 10^3 \times 25}{2 \times 705.04 \times 348} = 0.350 \text{ cm}^2$$

We take : 4HA8 = 2.01 cm<sup>2</sup>

□.6.6. Reinforcement diagram of a platform screen beam :

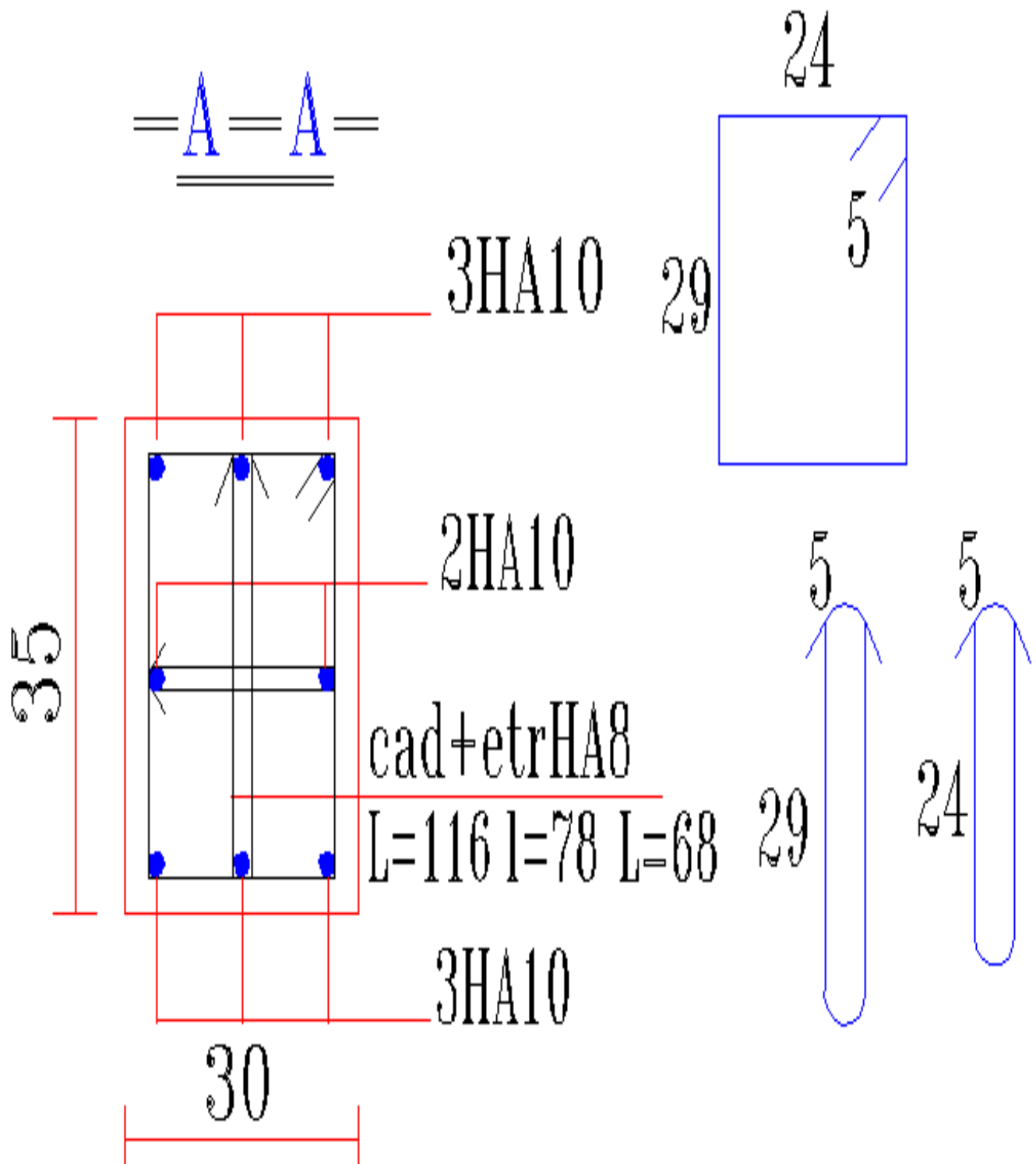

Figure III32:Reinforcement diagram of a platform screen beam

# CHAPTER IV

## SEISMIC AND DYNAMIC STUDY

## Seismic and dynamic study

### IV.1 Introduction:

Among the natural disasters that affect the earth's surface, tremors earthquakes are undoubtedly those, which have the most destructive effects in urbanized areas. Faced with this risk, and the impossibility of predicting it, it is necessary to build structures capable of resisting such phenomena, in order to ensure at least acceptable protection of human lives, hence the appearance of seismic construction. The latter is based generally on a dynamic study of constructions. The latter is generally based on a dynamic study of agitated constructions.

### IV.2 Modeling :

Modeling is the transformation of a real physical problem having an infinity of degrees of freedom (DDL) to a model having a finite number of DDL which describes the phenomenon studied as reliably as possible, in other words, this model must Reflect with good accuracy the behavior and parameters of the original system to have: mass, stiffness, damping and response.

One of the modeling methods is finite element modeling. It consists of discretized the structure has several elements, the unknowns are determined at the level of nodes. Using the interpolation function we sweep the element then the structure.

#### IV.2.1 Modeling software :

This software (Autodesk Robot Structural Analysis Professional 2010) allows us to automatically determine the dynamic characteristics of a structure (rigidity, displacement, effort, response) from a prior three-dimensional modalization is appropriate.

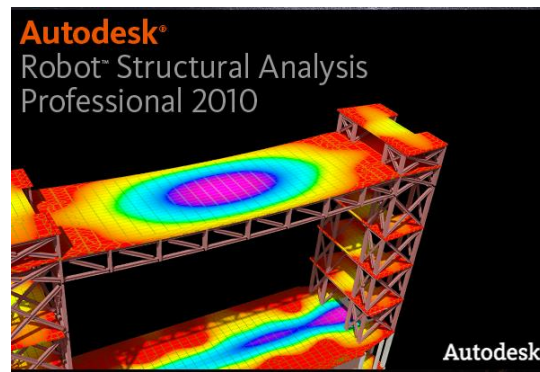

FigureIV.1 : Modeling software

The model adopted is embedded at the base, it only includes the elements (posts, beams, floor, staircase and sails), the rest of the elements are introduced as loading. Vertical loading is carried out using gravity loads (G and Q), and the horizontal loading is obtained by applying a response spectrum in both directions (X and Y) to have respectively ( $V_{xdyn}$  and  $V_{ydn}$ ).

### IV.2.2 Modeled elements :

The entire reinforced concrete supporting structure participating in the bracing of the building.

- For reinforced concrete walls, we used  $\Rightarrow$ shell type.
- For hollow-core slabs, we used deck slab  $\Rightarrow$ type in one direction.
- For balconies and stairs, we used  $\Rightarrow$ shell type.
- For the posts and beams, we used  $\Rightarrow$ bar type.

### IV.2.3 Structure mesh:

The mesh of the surface elements we opted for the COONS method, with a mesh size of 0.50 m. square type (rectangular outline). Mesh size adopted allows to mesh the surface elements with while having a precision of results and an acceptable calculation time.

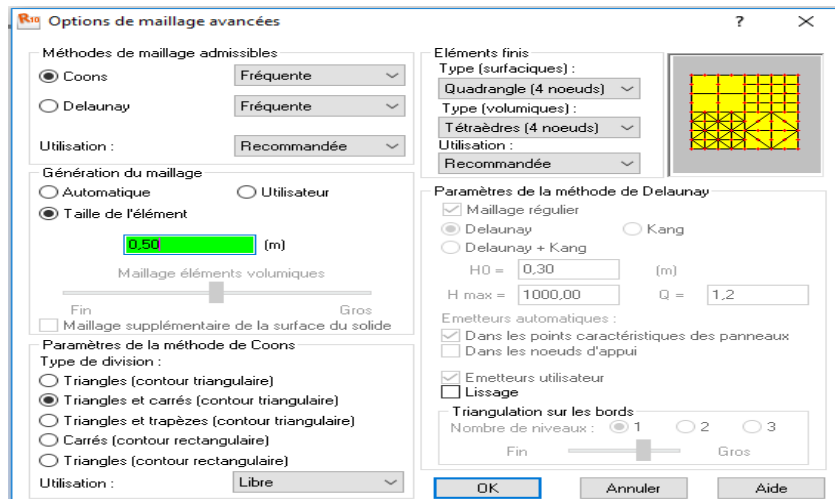

FigureIV.2 : Mesh options adopted for our

#### IV.2.4 Modeling steps:

##### ➤ Choice of structure type:

For our case, we will study a shell-type structure design as shown in the figure.



Figure IV.3 : Choice of structure type

##### ➤ Configuring case preferences:

To define the different parameters such as the materials, units and standards of the case, click on the “tool” icon... "case preferences".

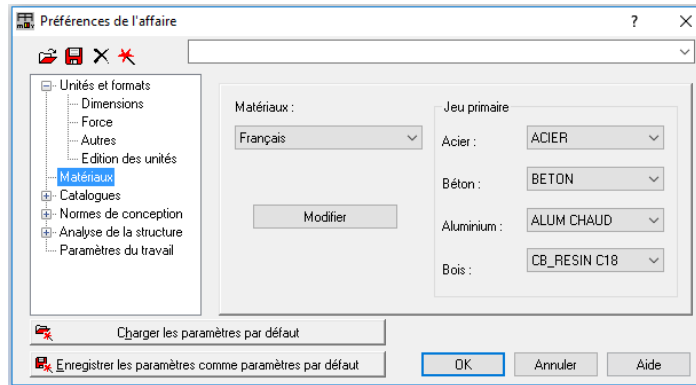

Figure IV.4 : Case preferences

**Dimensions :**

Dimensions de la structure :	m	0,21	E
Dimensions de la section :	cm	0,1	E
Caractéristiques de la section :	cm	0,21	E
Assemblages acier (dimensions) :	mm	0,	E
Barres du ferrailage (diamètre) :	mm	0,1	E
Section d'acier du ferrailage :	cm2	0,21	E
Largeur des fissures :	mm	0,1	E

**Strength :**

Force :	T	0,21	E
Moment :	T*m	0,21	E
Contrainte :	MN/m2	0,21	E

**Other :**

Déplacement linéaire :	cm	0,1	E
Angle / rotation (données) :	Deg	0,1	E
Angle / rotation (résultats) :	Rad	0,321	E
Température :	°C	0,21	E
Poids :	T	0,21	E
Masse :	t	0,21	E
Valeur numérique sans unité :		0,21	E
Règle :		0,1	E

**Materials :**

Matériaux :	Français	Modifier
Jeu primaire	Acier :	ACIER
	Béton :	BETON
	Aluminium :	ALUM CHAUD
	Bois :	CB_RESIN C18

**Standard And Design :**

Structures acier et aluminium :	CM66
Assemblages acier :	CM66
Structures bois :	CB71
Béton armé :	BAEL 91 mod. 99
Géotechniques :	DTU 13.12
	Plus de normes...

**charge :**

Pondérations :	BAEL 91
Charges de neige et vent :	DTR C2-47/NV99
Charges sismiques :	RPA 99 (2003)
	Plus de nomes...

**Structural Analysis:**

Méthode de résolution: Automatique (Paramètres)

Ignorer les avertissements:  Oui  Non

Vérification automatique: seulement erreurs

Si l'option exige des résultats de: demander si démarrer les calculs

Figurer automatiquement les résultats de calcul de la structure

Fusionner les barres automatiquement lors de l'import de la géométrie

Algorithme DSC (Relâchements sur barres)

Liaisons rigides (Liaisons rigides)

**Modal Analysis :**

Coefficients de participation modale:  Somme des valeurs absolues  Racine de la somme des carrés

Type de matrice de masses:  Cohérentes  Concentrées avec rotation  Concentrées sans rotation

Itération dans le sous-espace

Méthode de Lanczos

➤ **Definition of static loads :**

To define static loads (permanent and of operations) of the structure, in the “Loading”... “Load case” menu we choose the nature and the name then click on “New”

**Cas de charge**

Description du cas

Nature: permanente (Nouveau)

Numéro: 24 Préfixe: PERM5

Nom: PERM5

Liste de cas définis:

N°	Nom de cas	Nature
➔ 1	PP	permane...
2	g	permane...
3	Q	d'exploit...

Modifier Supprimer Supprimer tout

Fermer Aide

➤ **Allocation of charges:**

To load the structure we choose the type of load G (permanent) or Q (operation); We select from the drop-down menu: Loads ... define loads ... surface ... load uniform surface area.

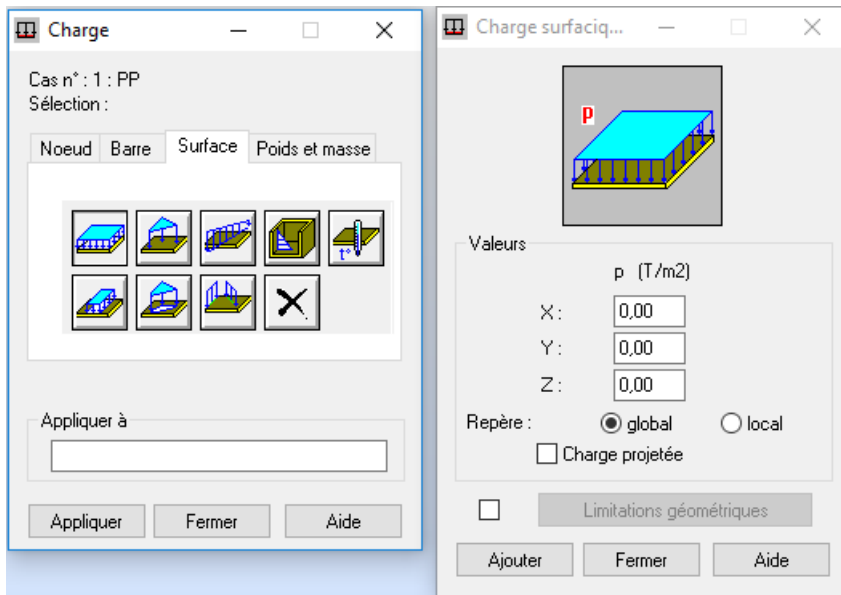

**Structural Analysis:**

We must introduce the law:  $W G + \beta Q$  For this, on the drop-down menu click on: Analysis ... type of analysis ... mass.

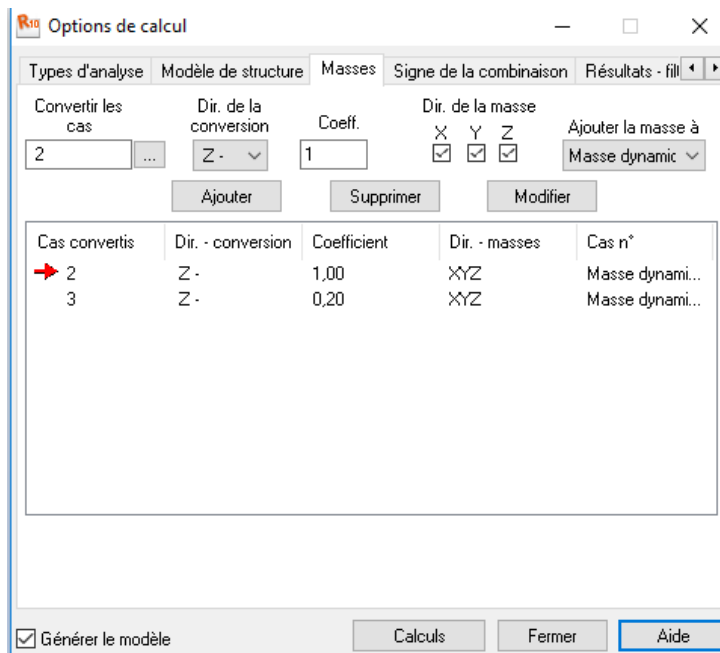

- **Modal analysis :**

- **Seismic analysis :**

- **Combination of loads:**

Loads ... manual combinations... We choose the type of the combination and its nature, Thus we introduce the static loads “ELU,ELS” and similarly the seismic combinations “G + Q ± E; 0.8 G ± E”

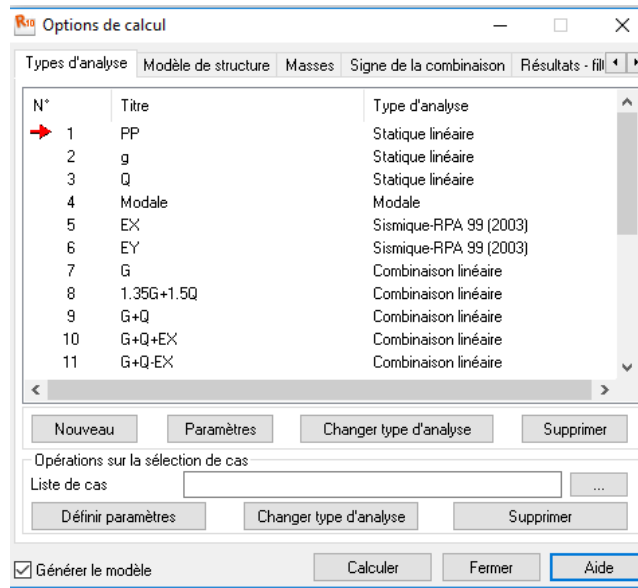

**Construction lines :**

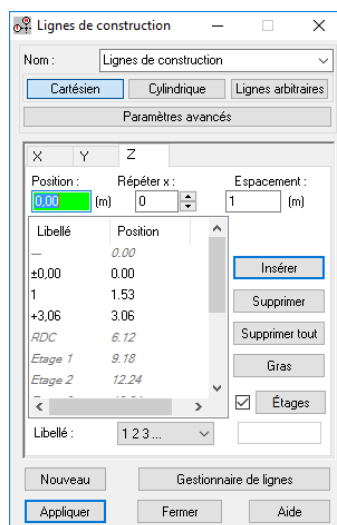
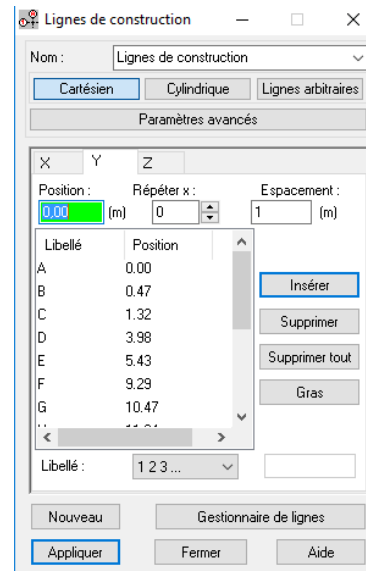
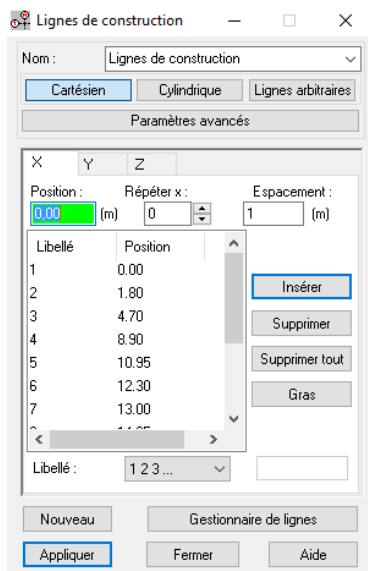

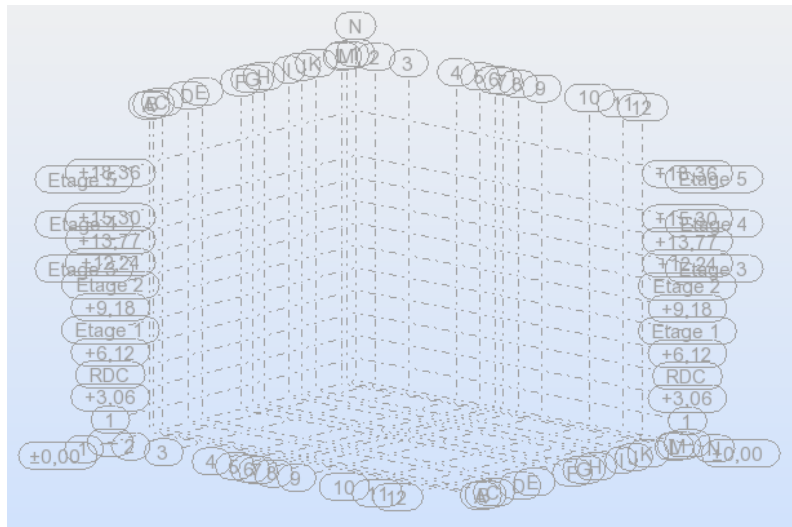

➤ **Definition of bar elements( posts, beams) :**

This step allows us to introduce the different cross sections of bar elements that exist in the structure.... Structure ...features ...bar profiles

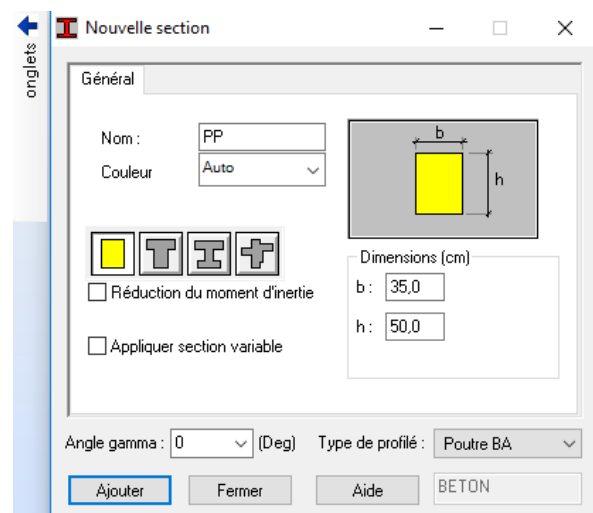
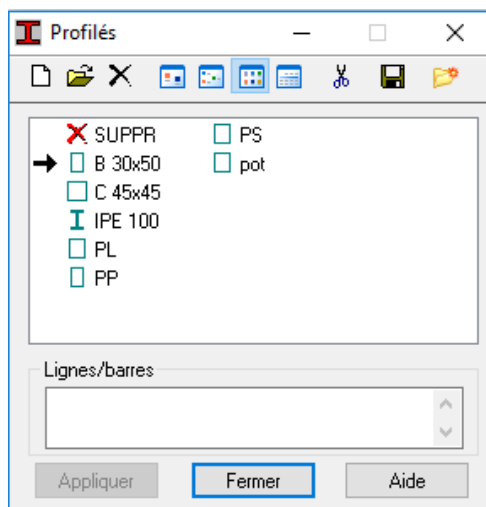

➤ **Definition of surface elements (panels):**

From the drop-down menu:...structure...characteristics... Thickness EF

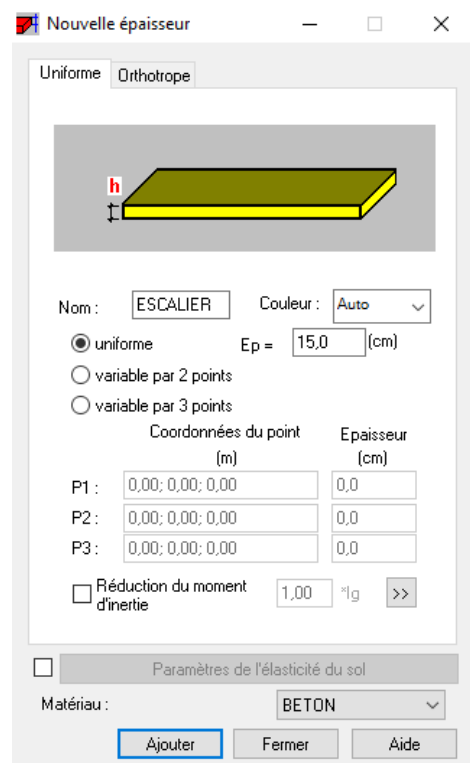
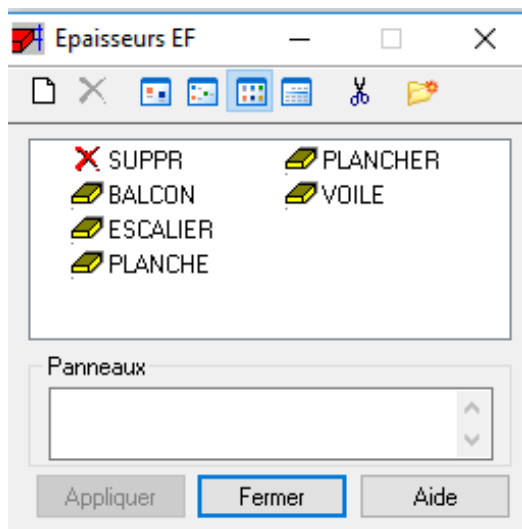

- **calculation of the structure:** After modeling and verification of the structure, if it does not present any error, we proceed to the static calculation.. Analysis

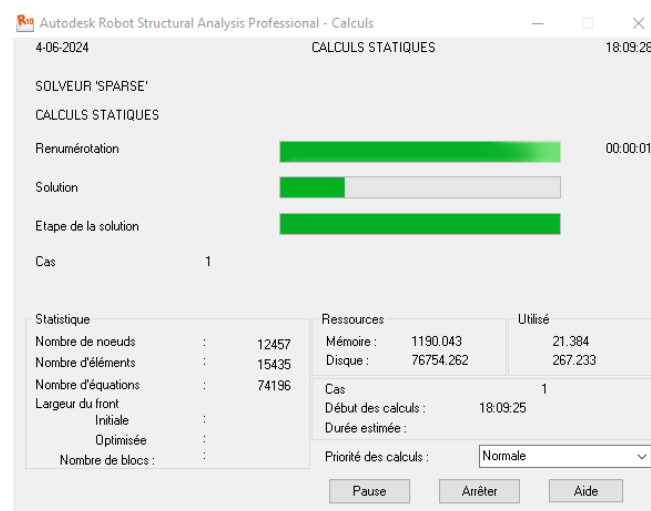

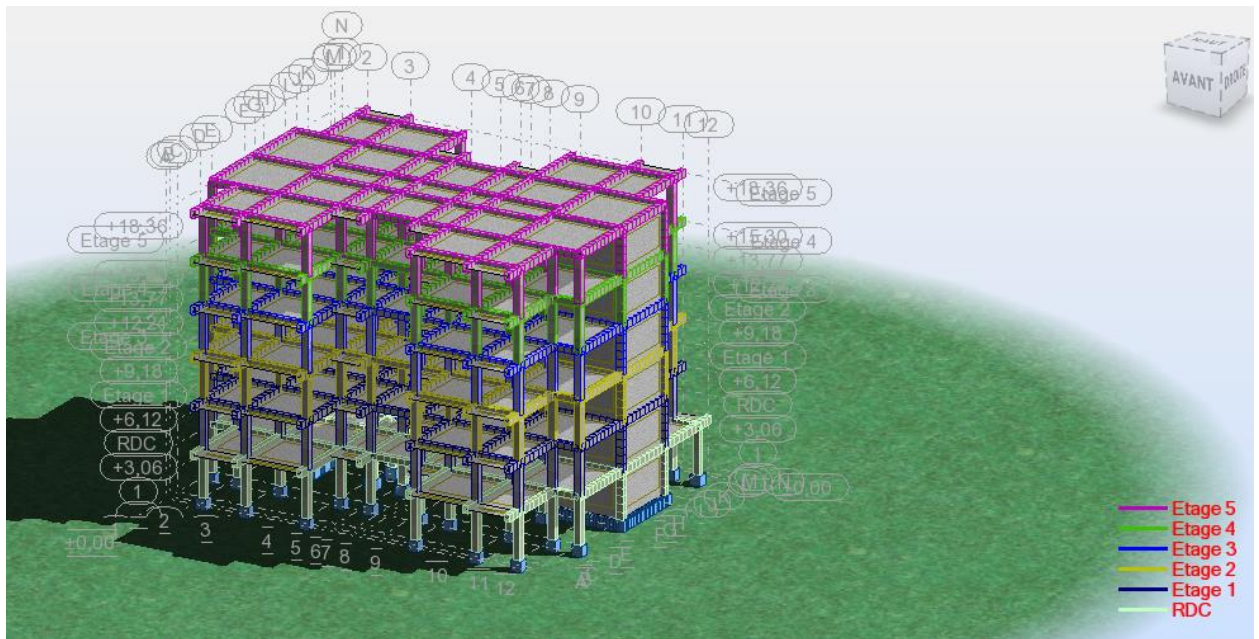

Figure IV.5 : 3D view of the structure

### IV.3 Classification criteria by RPA 99 version 2003:

A set of classifications necessary to define the seismic situation studied and the choice of the method and parameters for calculating seismic forces.

#### IV.3.1 Classification of seismic zones:

The national territory is divided into five (05) zones of increasing seismicity, defined on the seismic zone map and the associated table which specifies this distribution by province and by municipality, namely:

- Zone 0: Negligible seismicity
- Zone I: Low seismicity
- Zone IIa and IIb: Moderate seismicity
- Zone III: High seismicity

Our construction is located in the Skikda province, therefore in zone IIa (moderate seismicity).

### **IV.3.2 Classification of structures according to their importance :( RPA 99 version 2003)**

The minimum level of seismic protection granted to a structure depends on its purpose and its significance with respect to the protection objectives set by the community.

The lists described below are necessarily incomplete. However, they serve to illustrate this classification aimed at protecting the community's people, followed by its economic and cultural assets.

This classification recommends minimum protection thresholds that a project owner can only modify by upgrading the structure for increased protection, considering the nature and purpose of the structure with respect to the objectives targeted. Any structure falling under the scope of these rules must be classified into one of the four (04) groups defined below :

- Group 1A: Vital importance structures
- Group 1B: High importance structures
- Group 2: Common or moderate importance structures
- Group 3: Low importance structures

Our building is for collective residential use; therefore, it is classified in Group 2 (common or moderate importance structure).

### **IV.3.3 Site classification :**

Sites are classified into four (04) categories based on the mechanical properties of the soils they consist of:

- **Category S1 (rocky site):**

Rock or other geological formation characterized by an average shear wave velocity ( $V_s$ )  $\geq$  800m/s.

- **Category S2 (firm site) :**

Deposits of very dense sand and gravel and/or consolidated clay over 10 to 20 meters thick with  $V_s \geq 400$  m/s starting from 10 meters depth.

- **Category S3 (soft site):**

Thick deposits of moderately dense sand and gravel or moderately stiff clay with  $V_s \geq 200$  m/s starting from 10 meters depth.

- **Category S4 (very soft site) :**

Deposits of loose sands with or without layers of soft clay with  $V_s < 200$  m/s in the first 20 meters.

Deposits of soft to moderately stiff clay with  $V_s < 200$  m/s in the first 20 meters.

According to the geotechnical report relating to our building, we are in the presence of loose soil category S3.

#### **IV.3.4 Classification of bracing systems: (RPA99/Version2003 Art 3.4):**

The purpose of the classification of structural systems is translated in the rules and calculation methods by assigning for each category of this classification a numerical value of the behavior coefficient R (see Table 4.3 (RPA 99/V2003)).

The classification of structural systems is done taking into account their reliability and their ability to dissipate energy concerning seismic action, and the corresponding behavior coefficient is set based on the nature of constituent materials, the type of construction, possibilities of effort redistribution within the structure, and the deformation capacities of elements in the post-elastic domain.

In our case, the structure is braced by a system consisting of frames and shear walls.

#### **IV.3.5 Classification of the structure according to its configuration: (RPA99/Version2003 Art 3.5)**

Each building (and its structure) must be classified according to its plan and elevation configuration as either regular or irregular, based on the following criteria:

**a. Plan Regularity**

A building is classified as having regular plan if all criteria of plan regularity (a1 to a4) are met. Conversely, it is classified as having irregular plan if any of these criteria are not satisfied.

a1. The building must have a configuration that is substantially symmetrical with respect to two orthogonal directions, both for the distribution of rigidities and for the distribution of masses.

a2. At each level and for each calculation direction, the distance between the center of gravity of masses and the center of rigidities does not exceed 15% of the dimension of the building measured perpendicular to the direction of the seismic action considered.

a3. The shape of the building must be compact with a length/width ratio of the floor plan less than or equal to 4.

$$\frac{25.60}{21.10} = 1.21 < 4 \dots \dots \dots CV$$

The sum of the dimensions of the recessed or protruding parts of the building in a given direction must not exceed 25% of the total dimension of the building in that direction.

a4. The floors must have sufficient rigidity compared to that of the vertical bracings to be considered as rigid in their plane. In this context, the total surface area of floor openings must remain less than 15% of that of the floor.

All criteria of plan regularity (a1 to a4) are met, thus the structure is classified as regular in plan.

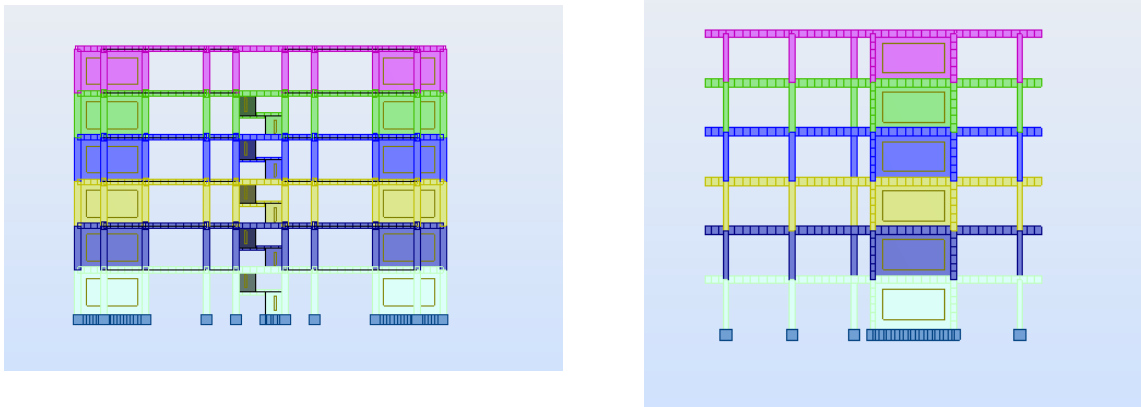
**b.Elevation Regularity :**

FigureIV.6 : Viewed in plan in each direction

A building is classified as regular in elevation if all criteria of elevation regularity (b1 to b4) are met. Conversely, it is classified as irregular in elevation if any of these criteria are not satisfied.

b1. The bracing system must not have discontinuous vertical load-bearing elements, whose load is not directly transmitted to the foundation.

b2. Both the stiffness and the mass of the different levels remain constant or gradually decrease without sudden loading from the base to the top of the building.

b3. The mass-to-stiffness ratio of two successive levels must not vary by more than 25% in each calculation direction. The variation in mass and stiffness from one floor to another is negligible.

b4. In the case of setbacks in elevation, the variation in plan dimensions of the building between two successive levels does not exceed 20% in both calculation directions and occurs only in the direction of decreasing height. The greatest lateral dimension of the building does not exceed 1.5 times its smallest dimension. No setback in elevation in both directions.

All criteria of elevation regularity (b1 to b4) are met, thus the structure is classified as regular in elevation.

## **IV.4 Presentation of the different methods for estimating seismic forces :**

The seismic study involves assessing the effects of accidental action (earthquake) on our existing structure. For this purpose, several approximate methods have been proposed to evaluate the internal forces generated within the structure. The calculation of these seismic forces can be determined using three methods:

- The equivalent static method.
- The spectral modal analysis method.
- The dynamic analysis method using accelerograms.

### **IV.4.1 The equivalent static method : (RPA99/Version2003 Art 3.5)**

- **Principle of the method:**

The actual dynamic forces that develop in the structure are replaced by a system of fictitious static forces whose effects are considered equivalent to ground motion in any direction in the horizontal plane.

The equivalent horizontal seismic forces will be considered applied successively along two orthogonal characteristic directions chosen a priori by the designer.

- **Modeling:**

The building model to be used in each of the two calculation directions is planar, with masses concentrated at the center of gravity of the floors and a single degree of freedom in horizontal translation per level, provided that the bracing systems in both directions can be decoupled.

The lateral stiffness of the load-bearing elements of the bracing system is calculated based on the unfissured sections for reinforced concrete or masonry structures.

Only the fundamental mode of vibration of the structure is to be considered in the calculation of the total seismic force.

### **IV.4.2 Modal spectral dynamic method :(RPA99/Version2003 Art3.5)**

- **Principle of the method:**

In this method, the maximum effects generated in the structure by the seismic forces represented by a response spectrum are sought for each mode of vibration. These effects are then combined

to obtain the structure's response. The natural modes depend on the mass of the structure, damping, and inertia forces.

- **Modeling:**

The building model to be used should best represent the distributions of stiffnesses and masses in order to take into account all significant modes of deformation in the calculation of seismic inertia forces.

- For structures with regular plans and rigid floors, the analysis is done separately in each of the two main directions of the building. The building is then represented in each of the two calculation directions by a planar model, fixed at the base, where masses are concentrated at the centers of gravity of the floors with a single degree of freedom in horizontal translation.

-For rigid floor structures, they are represented by a three-dimensional model, fixed at the base, where masses are concentrated at the centers of gravity of the floors with three degrees of freedom (two horizontal translations and one rotation about a vertical axis).

-For structures, whether regular or irregular, with flexible floors, they are represented by three-dimensional models fixed at the base with multiple degrees of freedom per floor.

-The deformability of the foundation soil must be taken into account in the model whenever the response of the structure depends on it significantly.

-The building model to be used must accurately represent the distributions of stiffnesses and masses to account for all significant modes of deformation in the calculation of seismic inertia forces (e.g., contribution of nodal zones and non-structural elements to the building's stiffness).

-For reinforced concrete or masonry buildings, the stiffness of load-bearing elements must be calculated considering the unfissured sections. If displacements are critical, especially in the case of structures associated with high values of the behavior coefficient, a more precise estimation of stiffness becomes necessary by considering cracked sections.

So the modeling is essentially based on four criteria specific to the structure and the site of installation:

1. Plan regularity.
2. Stiffness or flexibility of floors.
3. Number of degrees of freedom of concentrated masses.

4. Deformability of the foundation soil.

### IV.4.3 The dynamic analysis method using accelerograms :

- **Principle of the method :**

This method is based on studying the forces in the structure as a function of time, it requires the input of an accelerogram and practically requires the use of a computer.

The structure is assumed to be subjected to an earthquake that causes ground movements in a given direction, defined by the accelerogram. It is represented by a model for which the stiffness matrix, the mass matrix  $M$ , and the damping  $\xi$  are calculated, which is generally assumed to be identical for all modes.

- **Application domain :**

It is applied on a case-by-case basis for structures of significant importance by qualified personnel, who have previously justified the choices of design earthquakes and behavior laws used, as well as the method of interpreting results and the safety criteria to be satisfied

### IV.5 Geometric and Mass Characteristics of the Structure :

- **Center of gravity of masses :**

The masses are considered concentrated at the floor levels, so it is necessary to know the centers of mass which represent the points of application of lateral seismic forces. The center of mass is determined for each level by considering all elements that have an influence on the stability of the building (columns, beams, walls, stairs, shear walls, etc.).

$$X_{cm} = \frac{\sum m_i X_i}{\sum m_i} \quad Y_{cm} = \frac{\sum m_i Y_i}{\sum m_i}$$

**Table IV.1. : Center of mass of each floor**

Floor	$X_{cm}(m)$	$Y_{cm}(m)$

5	12.65	11.25
4	12.65	10.53
3	12.65	10.53
2	12.65	10.53
1	12.65	10.53
<b>Ground Floor</b>	12.65	10.49

▪ **Torsional center :**

The torsional center is the point through which the resultant of reactions from shear walls and columns passes. Any normal force exerted at this point will not produce any rotation. The position of the torsional center is determined using the following formulas:

$$X_{ct} = \frac{\sum l_{xi} X_i}{\sum l_{xi}} \quad Y_{ct} = \frac{\sum l_{yi} Y_i}{\sum l_{yi}}$$

**Tab IV.2 : Torsional center of each floor**

Floor	$X_{ct}(m)$	$Y_{ct}(m)$
5	12.65	10.51
4	12.65	10.49
3	12.65	10.49
2	12.65	10.49
1	12.65	10.49
<b>Ground Floor</b>	12.65	10.47

▪ **Eccentricity :**

**Theoretical (static) eccentricity :** It is the distance between the center of gravity of masses and the torsional center along the two axes, and it is calculated as follows:

$$e_{tx} = |X_{cm} - X_{ct}| \quad e_{ty} = |Y_{cm} - Y_{ct}|$$

**Accidental eccentricity ... (RPA99/Version2003 Art 4.2.7) :**

The Algerian seismic regulations require considering an accidental eccentricity equal to 5% of the largest dimension in plan of the level under consideration.

$$e_{ax} = 0.05L_x e_{ay} = 0.05L_y$$

**Tab IV.3 : Static and accidental eccentricity**

Floor	Theoretical eccentricity		Accidental eccentricity	
	$e_{tx}(m)$	$e_{ty}(m)$	$e_{ax}(m)$	$e_{ay}(m)$
<b>5</b>	0	0.72	1.265	1.047
<b>4</b>	0	0.04	1.265	1.047
<b>3</b>	0	0.04	1.265	1.047
<b>2</b>	0	0.04	1.265	1.047
<b>1</b>	0	0.04	1.265	1.047
<b>Ground Floor</b>	0	0.02	1.265	1.047

### Restrained eccentricity :

To account for the fact that eccentricity must be considered on both sides of the torsional center, we must analyze the following four cases and consider the most unfavorable scenario:

$$e_x = |e_{tx} + e_{ax}|$$

$$e_x = |e_{tx} - e_{ax}|$$

$$e_y = |e_{ty} + e_{ay}|$$

$$e_y = |e_{ty} - e_{ay}|$$

These four cases are considered for the following reasons:

- To compensate for errors in calculating the center of gravity of masses.
- To account for non-uniform distribution of loads.
- To compensate for execution errors.

The following table summarizes the previous results:

Tab TV.4 : Restrained eccentricity

Floor	$e_x =  e_{tx} + e_{ax} $ (m)	$e_x =  e_{tx} - e_{ax} $ (m)	$e_y =  e_{ty} + e_{ay} $ (m)	$e_y =  e_{ty} - e_{ay} $ (m)	$e_{xr}$ (m)	$e_{yr}$ (m)
5	1.265	1.265	1.767	0.327	1.265	1.767
4	1.265	1.265	1.087	1.007	1.265	1.087
3	1.265	1.265	1.087	1.007	1.265	1.087
2	1.265	1.265	1.087	1.007	1.265	1.087
1	1.265	1.265	1.087	1.007	1.265	1.087
GF	1.265	1.265	1.067	1.027	1.265	1.067

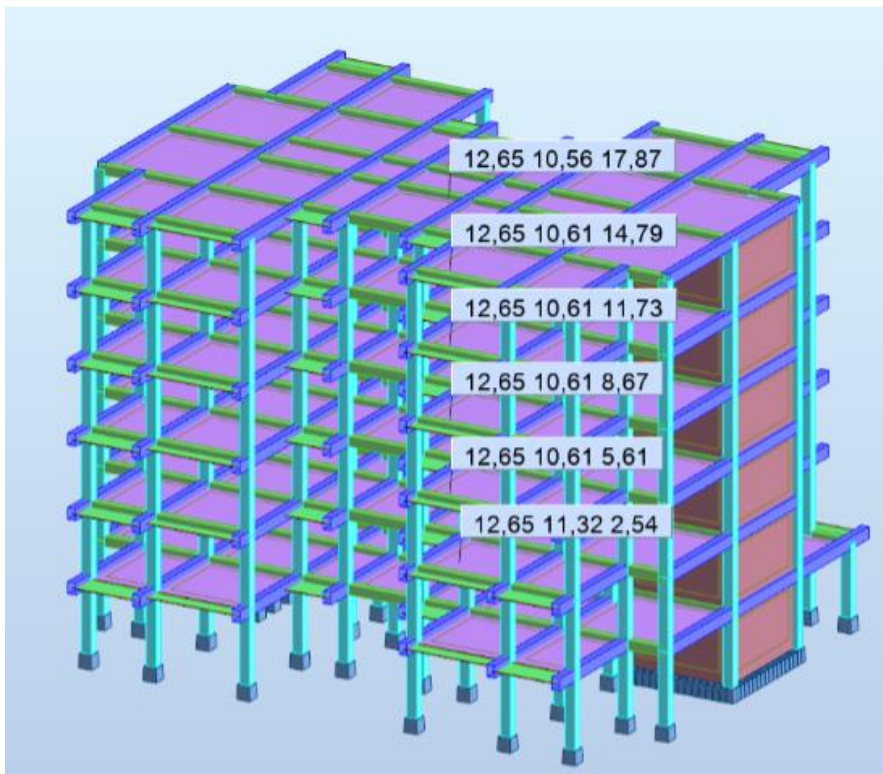

FigureIV.7 : Theoretical eccentricity

## IV.6 Structure Analysis :

The structure we propose to model is a building characterized by its regular shape in plan and elevation, braced by a mixed system (frame walls). It presents identical architecture on each floor. All of this simplifies the choice of wall positioning. Indeed, the choice of wall positioning must satisfy a number of conditions :

- The number of walls must be sufficiently high to ensure adequate rigidity while remaining within the realms of economic feasibility and ease of construction.
- The positioning of these walls must avoid detrimental torsional forces on the structure.

#### IV.6.1 Principles of Arrangement of Bracing Elements (Walls) :

The primary concern of the structural engineer should be to plan the arrangement of bracing walls ensuring overall stability, especially the overall bracing of the buildings. The pursuit of simplicity and good regularity in forms, in the distribution of load-bearing elements, is a fundamental principle of good seismic design. This not only ensures resistance to horizontal forces considered in the calculations but also potentially allows buildings to withstand, without excessive damage, the effects of certain exceptional loads.

##### ▪ Number of bracing elements :

The number of bracing elements must be such that under seismic action, their resistances are not exceeded nor their displacements excessive. When floors and roofs can be considered perfectly rigid in their plane, theoretically, three bracing elements per level are sufficient, provided they are non-concurrent and non-parallel; two to resist translations of the diaphragm respectively in the x, y directions, and a third producing, with one of the other two, a couple resisting vertical axis torsion.

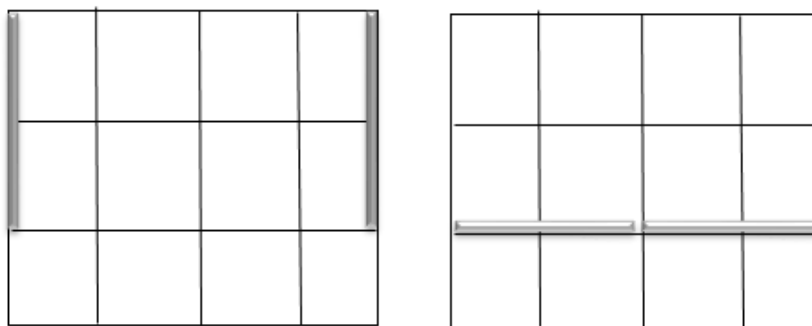

Figure IV.8 : Number of Walls

However, it is significantly preferable to use a higher number (hyperstatic system):

- Distribute horizontal loads across multiple elements;
- Avoid flexibility in the plane of long-span floors;

- Compensate for potential local failures of weakened elements.

▪ **Overall torsional resistance :**

To achieve maximum overall torsional stiffness, it is necessary for the elements capable of providing torsional stiffness to the structure to be positioned as much as possible towards the perimeter of the construction. The construction layout with a single core (staircase, elevator), which is traditional in non-seismic zones, is not ideal a priori.

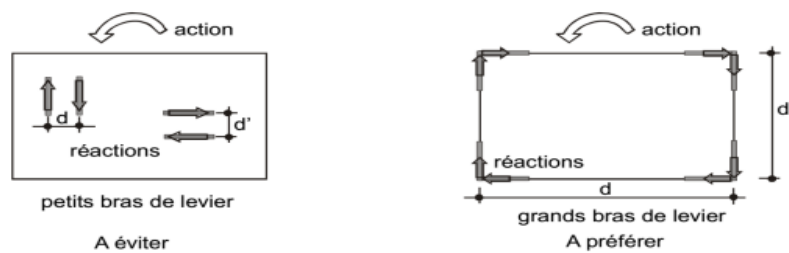

Figure IV.9 : Spacing between bracing elements. (AFPS, 0220)

• **Bracing width :**

In general, these elements should provide the construction with approximately the same rigidity in both the transverse and longitudinal directions in order to form an effective bracing system.

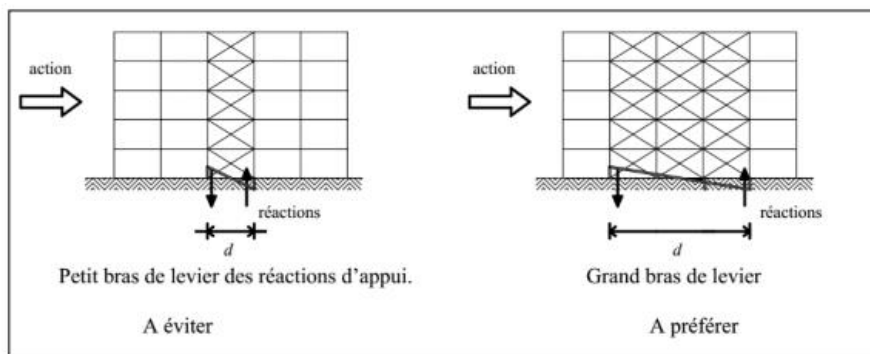

Figure IV.10 : Redundancy and a broad base ensure better distribution.

▪ **Distribution of vertical bracing elements :**

The distribution should be regular and continuous; the shear walls will preferably be stacked to provide the different levels with comparable stiffness in both translation and torsion.

The distribution should be regular and continuous; the shear walls should preferably be stacked to provide the different levels with comparable stiffness in both translation and torsion. By changing the section of the bracing elements from one floor to another, discontinuities are created, leading to abrupt variations in the stiffness and resistance of the building. This can result in heterogeneities in dynamic behavior, leading to additional stresses and problems with the transmission of forces at the local level.

- **Arranged symmetrically with respect to the center of gravity of the level :**

In the case of an asymmetrical distribution of bracing elements, the structure is subjected to additional forces due to vertical axis torsion during earthquakes.

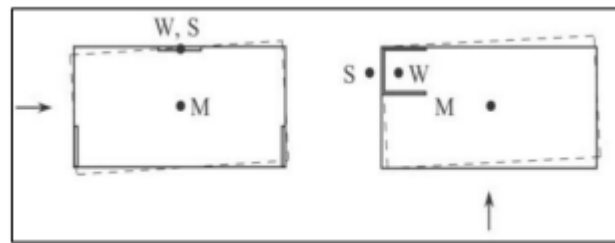
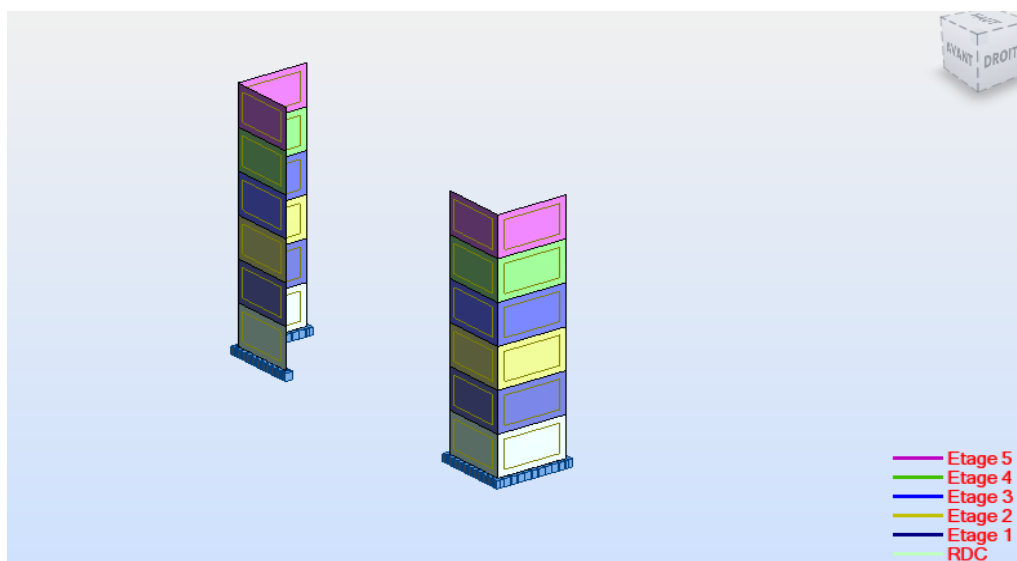

Figure IV.11 : Asymmetrical arrangement of shear walls should be avoided.

- **The arrangement of the bracing shear walls in our building :**



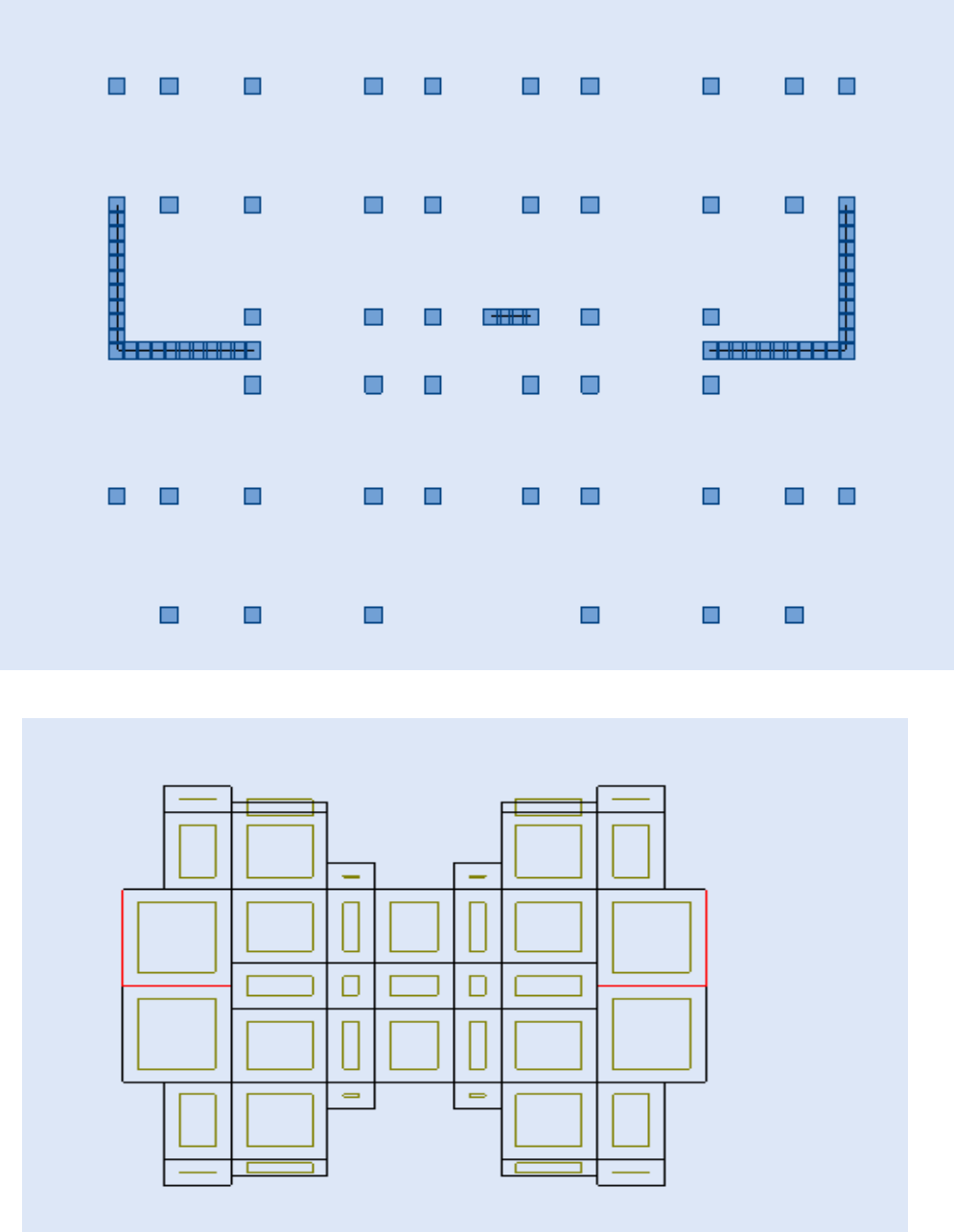

Figure IV.12 : Arrangement of the bracing shear walls

**IV.6.2 Calculation response spectrum :**

Seismic action is represented by the following calculation spectrum :

$$\frac{S_a}{g} = \begin{cases} 1.25A \left( 1 + \frac{T}{T_1} \left( 2.5\eta \left( \frac{Q}{R} - 1 \right) \right) \right) & 0 \leq T \leq T_1 \\ 2.5\eta(1.25A) \left( \frac{Q}{R} \right) & T_1 \leq T \leq T_2 \\ 2.5\eta(1.25A) \left( \frac{Q}{R} \right) \left( \frac{T_2^{\frac{2}{3}}}{T} \right) & T_2 \leq T \leq 3.0s \\ 2.5\eta(1.25A) \left( \frac{T_2^{\frac{2}{3}}}{3} \right) \left( \frac{3^{\frac{5}{3}}}{T} \right) \left( \frac{Q}{R} \right) & T > 3.0 s \end{cases}$$

- A: Zone acceleration coefficient
- $\eta$ : Damping correction factor.
- R: Structural behavior coefficient.
- T1, T2: Characteristic periods associated with the site category.
- Q: Quality factor"

**T2: Characteristic period associated with the site category as given by Table (4.7).**

**Tab IV.5. : Values of T1 and T2 (Table 4.7. RPA)**

site	S <sub>1</sub>	S <sub>2</sub>	S <sub>3</sub>	S <sub>4</sub>
T <sub>1</sub> (s)	0.15	0.15	<b>0.15</b>	0.15
T <sub>2</sub> (s)	0.30	0.40	<b>0.50</b>	0.70

The site category is S3 (soft site), therefore T1 = 0.15 sec and T2 = 0.50 sec.

- **A: Zone acceleration coefficient:**

The zone acceleration coefficient depends on the seismic zone and the building's occupancy group.

**Tab IV.6. Zone acceleration coefficient (Table 4.1. RPA)**

Group	zone			
	IA	IIA	IIB	III
1A	0.15	0.25	0.30	0.40
1B	0.12	0.20	0.25	0.30
2	0.10	<b>0.15</b>	0.20	0.25

3	0.07	0.10	0.14	0.18
---	------	------	------	------

In our case, we have an occupancy group 2 in seismic zone IIa, so  $A = 0.15$ .

▪ **Overall structural behavior coefficient:**

Justification of the Load-Bearing Capacity of structural elements regarding vertical and horizontal loads:

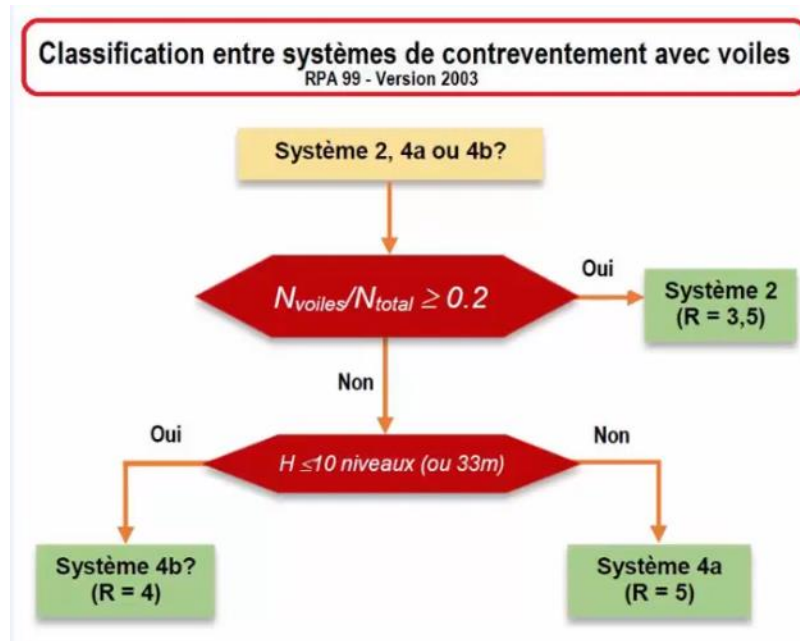

Figure IV.13 : Flowchart for Justification of the R coefficient.

The vertical loads resisted by the bracing system are provided by Robot Structural Analysis Professional 2010 under the combination  $(G + 0.2Q)$ :

**Tab IV.7 : The vertical loads supported by the bracing system**

Floor	Normal Force		
	$N_{posts}$ (T)	$N_{sail}$ (T)	$N_{total}$
5	-2471.10	-515.42	-2986.52
4	-2014.49	-425.19	-2439.68
3	-1614.68	-340.40	-1955.09
2	-1217.00	-253.50	-1470.50
1	-822.76	-163.15	-985.91
Ground Floor	-437.15	-63.79	-500.94

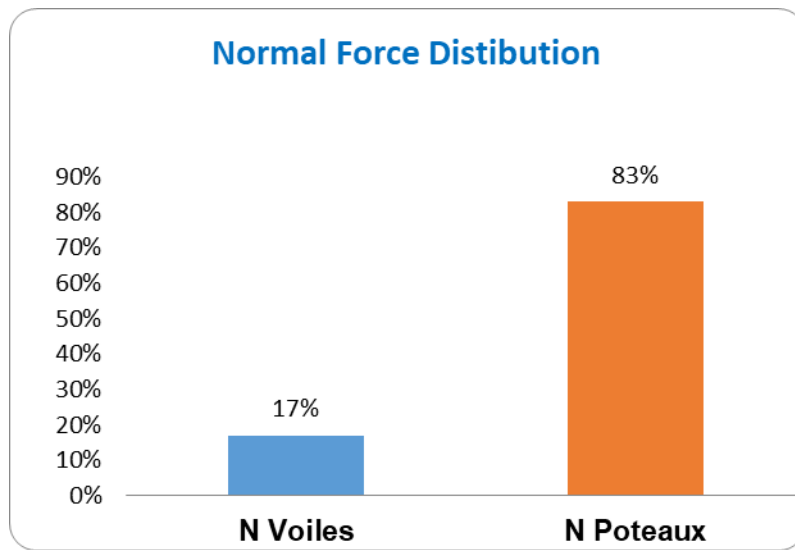

Figure IV.14 : Flowchart of Normal Force Distribution

The shear walls take more than 20% of the loads due to vertical forces; According to the modified RPA99 2003;The bracing is of type system 4b, constituted by shear walls. It is considered that the horizontal loading is solely resisted by the shear walls.

$$\frac{N_{sails}}{N_{total}} \geq 0.2 \dots \dots \dots CNV$$

$$H \leq 10 \text{ Levels} \Rightarrow H = 18.36\text{m} \leq 10\text{Levels} \dots \dots \dots cv$$

Therefore, the behavior coefficient :**R=4**

▪ **Damping correction factor:**

Given by the formula:  $\eta = \sqrt{\frac{7}{\xi + \varepsilon}} \geq 0.7$

Where  $\xi(\%)$  is the percentage of critical damping depending on the constituent material, structure type, and the significance of fillings, given by Table 4.2 (RPA 99/V2003).

**Tab IV.8 : Damping Value Table 4.2 RPA**

Fillings	Frames		Shear walls
	Reinforced concrete	Steel	Reinforced concrete/masonry
Light	6	4	

Dense	7	5	10
-------	---	---	----

▪ **Quality factor Q:**

The structure's quality factor depends on :

- Redundancy and geometry of its constituent elements
- Regularity in plan and elevation
- Quality of construction control

The value of Q is determined by formula (4-4. RPA 99/Version 2003):

$$Q = 1 + \sum_1^6 P_q$$

**P<sub>q</sub>**: is the penalty to be applied depending on whether the quality criterion "q" is satisfied or not.

Its value is given by Table [4.4] of the RPA 99/Version 2003.

**Tab IV.9 : Quality factor**

Criterion q	P <sub>q</sub> (following X)	P <sub>q</sub> (following Y)
Minimum requirements for bracing lines	0.05	0
Plan redundancy	0.05	0.05
Plan regularity	0.05	0.05
Elevation regularity	0.05	0.05
Quality control of execution	0.05	0.05
Quality control of materials	0.10	0.10
$Q = 1 + \sum_1^6 P_q$	1.35	1.3

All response spectrum data is known, so:

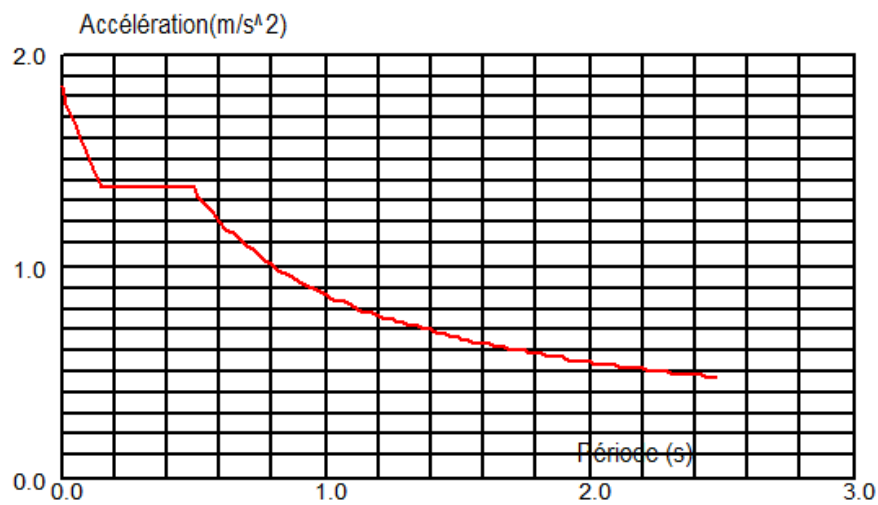

Figure IV.15 : Calculation response spectrum following X

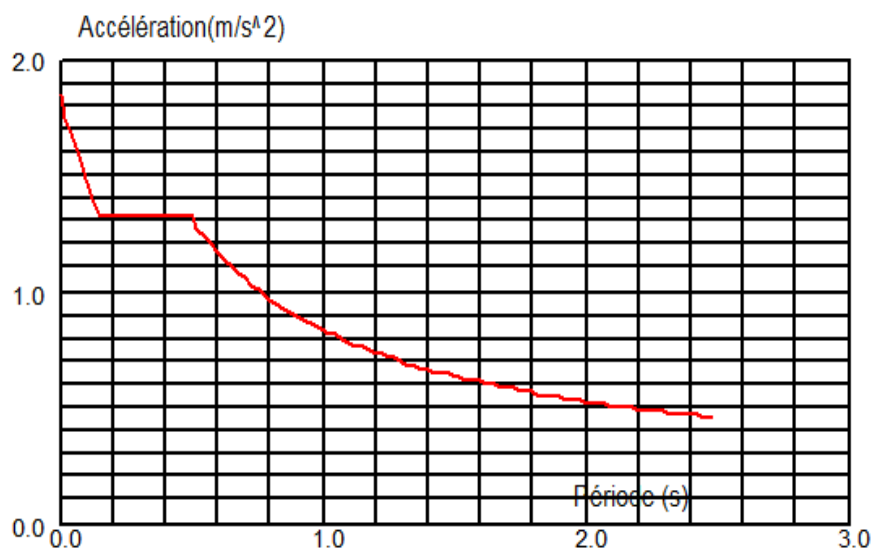

Figure IV.16 : Calculation response spectrum following Y

### IV.6.3 Results and verifications of dynamic analysis :

Common to both calculation methods (static and dynamic), the following verifications are necessary:

- Verification of behavior for the first three modes.
- Verification of mass participation
- Verification of reduced compression normal force

- Verification of resultant seismic forces
- Verification of overturning stability
- Verification of inter-story displacements
- Verification of top displacements
- Verification against P- $\Delta$  effect

#### IV.6.3.1 Verification of behavior for the first three modes :

The building has different responses according to the modes. It is necessary to target the modes that mobilize more mass first, and then the modes that mobilize the mass of the building in both directions, which means that the structure is subjected to torsion.

**Figure IV.10 : Behavior of the first three modes**

Mode	Frequency [HZ]	Period [sec]	Mass Modale UX[%]	Mass Modale UY[%]	Mass Modale UZ[%]	Behavior
1	2.71	0.37	63.07	0.00	0.00	Along the X axis
2	2.94	0.34	0.00	79.89	0.00	Along the Y axis
3	3.97	0.25	10.87	0.00	0.00	Rotation around the Z axis

#### ▪ Mode 1 :

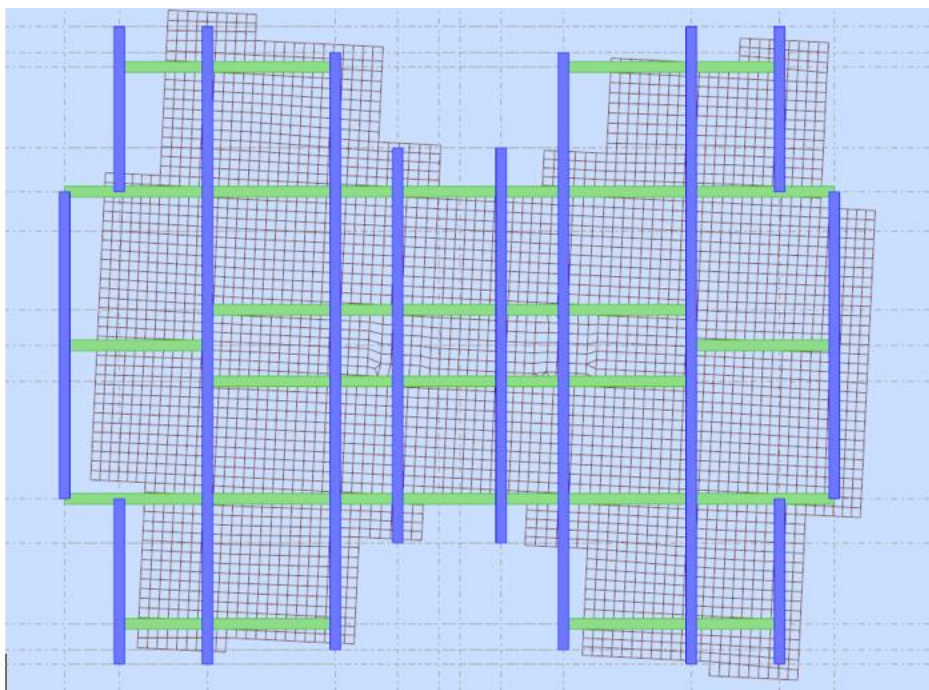

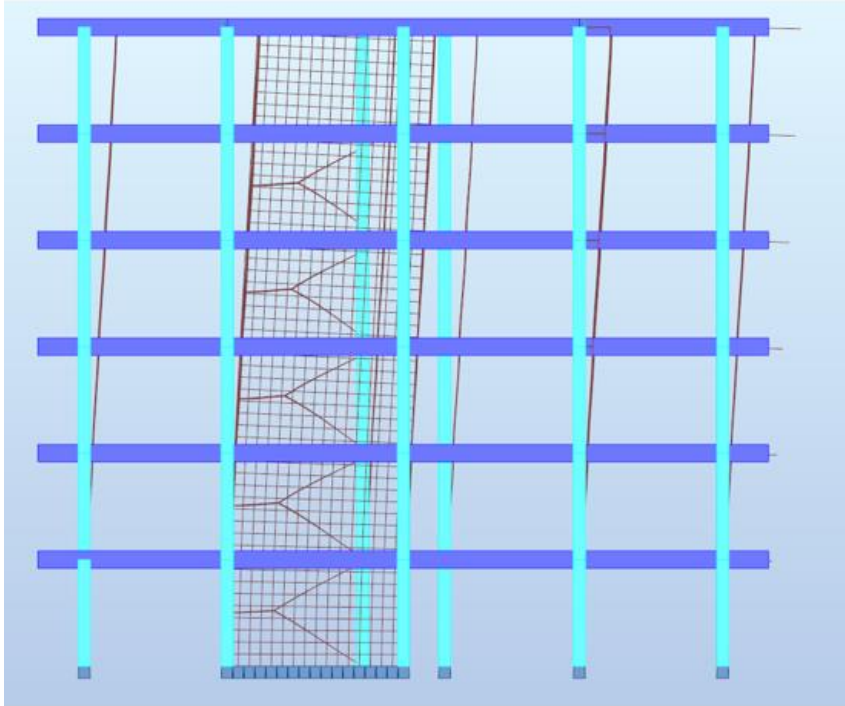

Figure IV.17 : Behavior of the 1st mode

▪ **Mode 02 :**

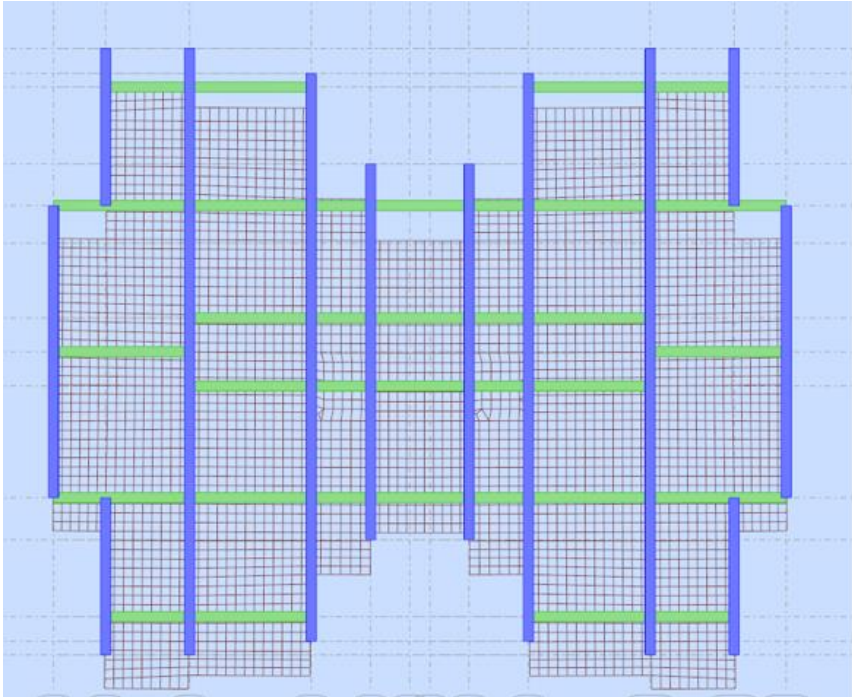

Figure IV.18 : Behavior of the 2nd mode

- **Mode 03 :**

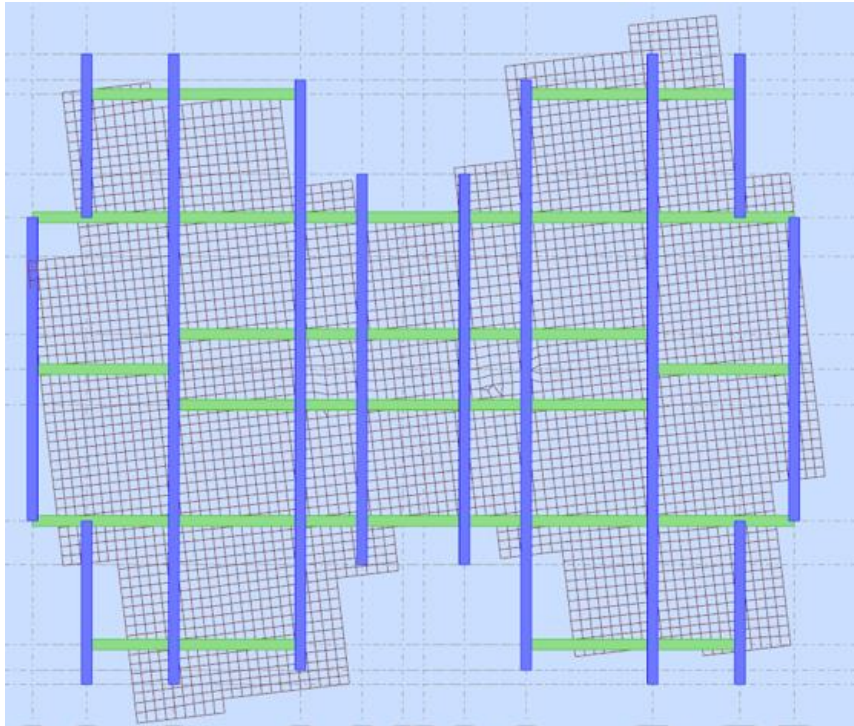

Figure 1Figure IV.19 : Behavior of the 3rd mode

#### IV.6.3.2 Verification of the specific mass participation :

a) For structures represented by plane models in two orthogonal directions, the number of vibration modes to be retained in each of the two excitation directions must be such that :

The sum of the effective modal masses for the selected modes shall be equal to at least 90% of the total mass of the structure.

Or that all modes with an effective modal mass greater than 5% of the total mass of the structure be retained for determining the total response of the structure.

The minimum number of modes to consider is three in each direction.

b) In cases where the conditions described above cannot be satisfied due to significant influence of torsional modes, the minimum number of modes (K) to be retained must...

must be such that :  $K \geq 3\sqrt{N}$  and  $T_k \leq 0.2$  sec

Where: N is the number of stories above ground level and TK is the period of mode K.  
(RPA99/Version2003 Art 4.3.4)

**Tab IV.11 : Verification of mass participation**

Mode N°	Frequency [HZ]	Period [sec]	Cumulative Masses UX [%]	Cumulative Masses UY [%]	Cumulative Masses UZ [%]
1	2.70	0.37	63.10	0.00	0.00
2	2.94	0.34	63.10	73.89	0.00
3	3.96	0.25	73.79	73.89	0.00
4	8.32	0.12	73.79	88.79	0.00
5	9.39	0.11	90.42	88.79	0.00
6	11.68	0.09	90.43	92.09	0.02
7	12.29	0.08	90.80	92.09	0.03
8	12.39	0.08	90.80	92.10	3.11
9	12.57	0.08	91.25	92.10	3.11
10	13.42	0.07	91.25	92.18	3.62
11	13.52	0.07	91.25	92.20	10.21
12	13.53	0.07	91.25	92.20	10.26

The structure has dissipated more than 90% of the stored energy at the 5th mode in the direction X and at the 6th mode in the direction Y.

#### IV.6.3.3 Verification of reduced compressive normal force (RPA99/Version2003 Art7.1.3.3) :

We must verify that :  $u = \frac{N_d}{B_c \times f_{c28}} \leq 0.3$

With:

- $N_d$ : The design normal force acting on a concrete section;
- $B_c$ : The area (gross section) of the concrete section;
- $f_{c28}$ : The characteristic strength of concrete.

We have the same posts section(35\*45) in every Floor of our building so :

$$u = \frac{111.77 \times 10^4}{(350 \times 450) \times 25} = 0.28 \text{mm} \leq 0.3 \dots \dots \text{cv}$$

**Tab IV.12 : Verification of the reduced normal force**

Floor	columns ( $m^2$ )	Combination	Nd(T)	Results	Verifi $\leq 0.3$
Floor	35*45	G + Q ± E	111.77	0.28	cv

**IV.6.3.4 Tangential solicitations (A.7.4.3.2 RPA99/2003) :**

The conventional calculation shear stress in concrete ( $\tau_{bu}$ ) under seismic combination must be less than or equal to the following limit value:

$$\bar{\tau}_{bu} = \rho_d f_{c28}$$

where  $\rho_d$  is equal to 0.075 if the geometric slenderness, in the considered direction, is greater than or equal to 5, and 0.04 otherwise.

The geometric slenderness is:

$$\lambda_g = \left( \frac{L_f}{a} \text{ or } \frac{L_f}{b} \right)$$

And :

$$\tau_{bu} = \frac{v}{b \times d}$$

With: a and b, dimensions of the cross-section of the column in the direction of deformation considered, and  $L_f$  is the buckling length of the column.

**According to X :**

**Tab IV.13 : Verification of Tangential Stresses along X-axis**

Floor	Columns( $m^2$ )	$L_f$	a	$\lambda_g$	$\rho_d$	$\tau_{bu}$	$\bar{\tau}_{bu}$	$\tau_{bu} \leq \bar{\tau}_{bu}$
GF	(35*45)	0.7	0.35	6.12	0.075	0.948	1.875	cv
Floor	(35*45)	0.7	0.35	6.12	0.075	0.948	1.875	cv

**According to Y :**

**Tab IV.14 : Verification of Tangential Stresses along Y-axis**

Floor	Columns( $m^2$ )	$L_f$	b	$\lambda_g$	$\rho_d$	$\tau_{bu}$	$\bar{\tau}_{bu}$	$\tau_{bu} \leq \bar{\tau}_{bu}$
GF	(35*45)	2.14	0.45	4.76	0.075	1.095	1.875	cv
Floor	(35*45)	2.14	0.45	4.76	0.075	1.095	1.875	cv

**IV.6.3.5 Verification of the resultant of seismic design forces :**

The resultant of seismic forces at the base,  $V_t$ , obtained by combining modal values, must not be less than 80% of the resultant of seismic forces determined by the equivalent static method,  $V$ , for a value of the fundamental period given by the appropriate empirical formula. (RPA99/Version2003 Art 4.3.6)

So, it is necessary to verify that :If  $V_t > 0.80V$ , all response parameters (forces, displacements, moments, etc.) will need to be increased proportionally  $\frac{0.8V}{V_t}$

**Calculation of the total seismic force V: (RPA99/Version2003 Art 4.2.3) :**

The total seismic force  $V$ , applied at the base of the structure, must be calculated successively in two orthogonal horizontal directions X, Y according to the formula :

$$v = \frac{A \cdot D \cdot Q}{R} W$$

With:

- A: Zone acceleration coefficient.  $A = 0.15$
- D: Average dynamic amplification factor;
- R: Overall structural behavior coefficient.  $R = 3.5$
- Q: Quality factor.  $Q_x = 1.35$ ;  $Q_y = 1.3$
- W: Total weight of the structure.

▪ **Average dynamic amplification factor:**

The average dynamic amplification factor is a function of the site category, the damping correction factor ( $\eta$ ), and the fundamental period of the structure ( $T$ ).

This coefficient is given by:

$$D \begin{cases} 2.5\eta & 0 \leq T \leq T_2 \\ 2.5\eta(T/T_2)^{2/3}T_2 & 2.5\eta(T/T_2)^{2/3}T_2 \leq T \leq 3.0s \\ 2.5\eta(T_2/3.0)^{2/3}(3.0/T)^{5/3} & T \geq 3.0s \end{cases}$$

- **Estimation of the fundamental period of the structure: (RPA99/Version2003 Art 4.2.4) :**

The value of the fundamental period (T) of the structure can be determined using empirical formulas or calculated through analytical or numerical methods.

Using the empirical formula:

The fundamental period corresponds to the smallest value obtained from formulas (4-6 and 4-7 of RPA99/Version 2003).

$$T_e = \min \left\{ C_t h_N^{3/4}; \frac{0.9h_N}{\sqrt{D}} \right\}$$

$h_N$ : height measured in meters from the base of the structure to the topmost level.

$$h_N = 3.06 \times 6 = 18.36\text{m}$$

$C_t$ : Coefficient, dependent on the bracing system, the type of infill, and provided by Table 4.6 of RPA 99/V2003:

Our structure is braced by reinforced concrete walls (CaseN°. 4) resulting in:  $C_T = 0.050$

$D$ : the dimension of the building measured at its base in the considered calculation direction.

$$D_x = 25.60\text{m} ; \quad D_y = 21.10\text{m}$$

$$C_t h_N^{3/4} = 0.050 \times 18.36^{3/4} = 0.443 \text{ sec}$$

$$\frac{0.09h_N}{\sqrt{D_x}} = \frac{0.09 \times 18.36}{\sqrt{25.60}} = 0.327 \text{ sec}$$

$$\frac{0.09h_N}{\sqrt{D_y}} = \frac{0.09 \times 18.36}{\sqrt{21.10}} = 0.359 \text{ sec}$$

$$\Rightarrow T_{x e} = \min \left\{ C_t h_N^{3/4}; \frac{0.09h_N}{\sqrt{D_x}} \right\} = \min\{0.443 \text{ s}; 0.327 \text{ s}\} = 0.327 \text{ s}$$

$$\Rightarrow T_{y e} = \min \left\{ C_t h_N^{3/4}; \frac{0.09h_N}{\sqrt{D_y}} \right\} = \min\{0.443 \text{ s}; 0.359 \text{ s}\} = 0.359 \text{ s}$$

**By the analytical method (modal analysis) :**

$$T_{x \text{ analytical}} = \mathbf{0.37 \text{ s}}$$

$$T_{y \text{ analytical}} = 0.34 \text{ s}$$

The T values calculated from numerical methods (analytical) should not exceed those estimated from appropriate empirical formulas by more than 30%.

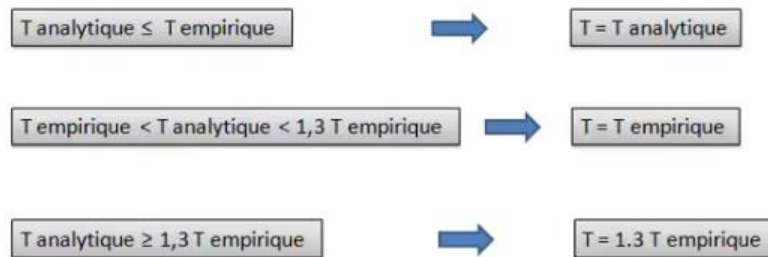

**According to X :**

$$T_{x e} = 0.327 \text{ s}$$

$$T_{x \text{ analytical}} = 0.370 \text{ s}$$

$$1.3T_{x e} = 0.327 \times 1.3 = 0.425 \text{ s}$$

$$\text{So : } T_{x e} = 0.327\text{s} < T_{x a} = 0.370\text{s} < 1.3T_{x e} = 0.425 \text{ s}$$

**According to Y :**

$$T_{y e} = 0.359 \text{ s}$$

$$T_{y \text{ analytical}} = 0.340 \text{ s}$$

$$1.3T_{y e} = 0.359 \times 1.3 = 0.467 \text{ s}$$

$$\text{So : } T_{y a} = 0.340 \text{ s} < T_{y e} = 0.359 \text{ s}$$

**Tab IV.15 : Verification of the fundamental period.**

	$T_e$	$T_{\text{analytical}}$	$1.3T_e$	The chosen period
<b>X-X</b>	0.327	0.370	0.425	0.327
<b>Y-Y</b>	0.359	0.340	0.467	0.340

**To calculate the mean dynamic amplification factor:**

**According to X** :  $0 < T_x = 0.327s < T_2 = 0.50 s$

$$D_x = 2.5 \times 0.76 = 1.91$$

**According to Y** :  $0 < T_y = 0.340 s < 0.50 s$

$$D_y = 2.5 \times 0.76 = 1.91$$

▪ **Total weight of the structure (W):**

W is equal to the sum of the weights  $W_i$  calculated at each level (i):

$$W = \sum_{i=1}^n W_i \quad ; \quad W_i = WGi + \beta WQi$$

With:

- WGi: weight due to permanent loads and those of any fixed equipment, integral with the structure.
- WQi: operating loads.
- $\beta$ : weighting coefficient, depending on the nature and duration of the operating load and given in Table 4.5 of RPA99/Version 2003.

In our case, for a building used for residential purposes,  $\beta=0.20$  is determined using Autodesk Robot Analysis Professional 2010, the total weight of the structure:

$$\mathbf{W=2630.32 T}$$

**Summary of results :**

**Tab IV.16 :Summary of results**

Parameters	A	R	$Q_x$	$Q_y$	$D_x$	$D_y$	W (T)
Value	0.15	4	1.35	1.3	1.91	1.91	2630.32

So the calculations will be provided:

$$V_x = \frac{0.15 \times 0.91 \times 1.35}{4} \times 2630.32 = 1211.75 \text{ KN} = 121.175 \text{ T}$$

$$V_Y = \frac{0.15 \times 0.91 \times 1.3}{4} \times 2630.32 = 1166.87 \text{ KN} = 116.687 \text{ T}$$

Using Autodesk Robot Analysis Professional 2021, the seismic force at the base  $V_t$ :

$$V_x = 179.51 \text{ T}$$

$$V_y = 199.67 \text{ T}$$

**According to X :**

$$\text{So : } 0.8 \times 121.175 = 96.94 \text{ T} \Rightarrow 179.51 > 96.94 \dots \dots cv$$

**According to Y :**

$$0.8 \times 116.678 = 93.35 \text{ T} \Rightarrow 199.67 > 93.35 \text{ T} \dots \dots cv$$

**IV.6.3.5 Verification of overturning stability: ... (RPA99/Version2003 Art 4.4.1)**

The overturning moment that may be caused by seismic action must be calculated with respect to the ground-foundation contact level.

we need to verify that:  $\frac{M_s}{M_r} \geq 1.5$

**a) The overturning moment:**

$$M_{rx} = \sum_{i=1}^n M_{rx_i} = \sum_{i=1}^n F_{iy} \times h_i$$

$$M_{ry} = \sum_{i=1}^n M_{ry_i} = \sum_{i=1}^n F_{ix} \times h_i$$

With:

- $F_{ix}$  and  $F_{iy}$ : the distributed forces at each level along x and y;
- $h_i$ : the height of the storey relative to the base.

**b) The stabilizing moment:**

$$M_{sx} = \sum_{i=1}^n M_i = \sum_{i=1}^n w_i \times Y_{Gi}$$

$$M_{sy} = \sum_{i=1}^n M_i = \sum_{i=1}^n w_i \times Y_{Gi}$$

With:

- XG and YG: the coordinates of the center of gravity of the structure
- Wi: the mass of the floor at each level.

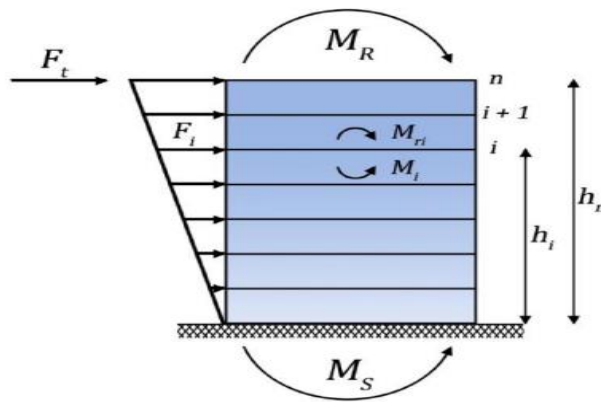

Figure IV.22. The forces acting on overturning stability

**IV.6.3.6 Distribution of the resultant seismic forces according to height: (RPA99/Version2003 Art 4.2.5)**

The resultant of seismic forces at the base  $V$  must be distributed over the height of the structure according to the following formulas:

$$V = F_t + \sum F_i$$

The concentrated force  $F_t$  at the top of the structure allows for the influence of higher modes of vibration. It must be determined by the formula:  $F_t = 0.07 TV$

where  $T$  is the fundamental period of the structure (in seconds). The value of  $F_t$  shall not exceed  $0.25V$  under any circumstances and shall be taken as 0 when  $T$  is less than or equal to 0.7 seconds. The remaining part of  $V$ , i.e.,  $(V - F_t)$ , must be distributed over the height of the structure according to the formula :

$$F_t = \frac{(V - F_t) \times W_i \times h_i}{\sum_{j=1}^n W_j h_j}$$

With :

- $F_i$ : horizontal force returning at level  $i$
- $h_i$ : level of the floor where force  $F_i$  is exerted
- $h_j$ : level of any floor
- $W_i, W_j$ : weight returning to floors  $i, j$

We have:  $T_x = 0.327 < 0.07$  ;  $T_y = 0.340 < 0.07$

So :  $F_t = 0$

So the formula for distributing the forces  $F_i$  becomes:

$$F_t = \frac{V \times W_i \times h_i}{\sum_{i=1}^n W_j h_j}$$

### Important Observation:

The Robot Structural Analysis Professional 2010 software provides shear forces and not seismic forces. We derive the values of seismic forces from the shear forces using the relation  $V = \sum F_i$

The overturning moment is calculated using the seismic forces ( $F_1, F_2, F_3, \dots F_7$ ) and not the shear forces. The results obtained are shown in the following table:

**Tab IV.17 : Distribution of the resultant of seismic forces**

Floor	wi(t)	hi(t)	wi*hi(t)	fix(t)	fiy(t)	vx(t)	vy(t)
5	487,71	3,06	1492,393	6,399	6,16	121,175	116,687
4	428,32	6,12	2621,318	11,240	10,82	121,175	116,687
3	428,32	9,18	3931,978	16,859	16,23	121,175	116,687
2	428,32	12,24	5242,637	22,479	21,65	121,175	116,687
1	428,32	15,3	6553,296	28,099	27,06	121,175	116,687
GF	458,56	18,36	8419,162	36,099	34,76	121,175	116,687
<b>Total</b>	2659,55		28260,783	121,175	116,69		

**Tab IV.18 : Overturning moment in both X and Y directions**

Floor	hi(t)	fix(t)	fiy(t)	Mrxi	Mryi
-------	-------	--------	--------	------	------

5	3,06	6,398	6,161	19,580	18,855
4	6,12	11,239	10,823	68,785	66,238
3	9,18	16,859	16,234	154,768	149,036
2	12,24	22,479	21,646	275,143	264,953
1	15,3	28,098	27,058	429,912	413,989
<b>GF</b>	18,36	36,099	34,762	662,781	638,233
<b>Total</b>				1610,973	1551,307

Tab IV.19 : Stability moment in both X and Y directions.

Floor	hi(t)	fix(t)	XG	YG	Mrxi	Mryi
5	3,06	487,71	12,65	10,49	6169,531	5116,077
4	6,12	428,32	12,65	10,53	5418,248	4510,209
3	9,18	428,32	12,65	10,53	5418,248	4510,209
2	12,24	428,32	12,65	10,53	5418,248	4510,209
1	15,3	428,32	12,65	10,53	5418,248	4510,209
<b>GF</b>	18,36	458,56	12,65	11,25	5800,784	5158,800
<b>Total</b>					33643,307	28315,716

We need to verify that:  $\frac{M_s}{M_r} \geq 1.5$

Tab IV.20 : Verification of overturning stability

	Ms	Mr	Ms/Mr	Ms/Mr $\geq$ 1,5
<b>x-x</b>	33643,31	1610,97	20,88	vr
<b>y-y</b>	28315,72	1551,31	18,25	vr

The structure is stable against overturning in both directions.

#### IV.6.3.7 Verification of inter-floor displacements :

The horizontal displacement at each level 'k' of the structure is calculated as follows:

$$\delta_k = R\delta_{ek}$$

With :

- $\delta_{ek}$ : Displacement due to seismic forces  $F_i$  (including torsional effects).
- **R**: behavior factor

The displacement relative to level 'k' with respect to level 'k-1' is equal to:

$$\Delta k = \delta k - \delta_{ek}$$

According to (RPA99/Version2003 Art 5.10), the lateral relative displacements of one floor with respect to adjacent floors must not exceed 1.0% of the floor height unless it can be demonstrated that a greater relative displacement can be tolerated.

$$\bar{\Delta} = 0,01h_e$$

$h_e$ : the height of the floor K

The verification results are provided in the following tables:

**Tab IV.21 : Inter-story displacement verification along the X direction**

Floor	Sk	$\Delta k$	$\bar{\Delta}$	$\Delta k < \bar{\Delta}$
<b>5</b>	8	1,2	3,06	vr
<b>4</b>	6,8	1,6	3,06	vr
<b>3</b>	5,2	1,7	3,06	vr
<b>2</b>	3,6	1,6	3,06	vr
<b>1</b>	2	1,2	3,06	vr
<b>GF</b>	0,8	0,8	3,06	vr

**Tab IV.22 : Inter-story displacement verification along the Y direction**

Floor	Sk	$\Delta k$	$\bar{\Delta}$	$\Delta k < \bar{\Delta}$
<b>5</b>	1,9	0,3	3,06	vr
<b>4</b>	1,6	0,3	3,06	vr
<b>3</b>	1,3	0,4	3,06	vr
<b>2</b>	0,9	0,4	3,06	vr
<b>1</b>	0,5	0,3	3,06	vr
<b>GF</b>	0,2	0,2	3,06	vr

**IV.6.3.8 Verification of displacements at the top :**

$$\delta_k = \frac{\text{height of the floor}}{250} = \frac{3.06 \times 6}{250} = 0.0734m \Rightarrow 7.34cm$$

**Tab IV.23 : Verification of displacements at the top following both directions.**

	<b>Sk</b>	<b>Slimit</b>	<b>s&lt;sli</b>
<b>x-x</b>	8	7,3	vr
<b>y-y</b>	1,9	7,3	vr

**IV.6.3.8 Justification with respect to the P-Δ effect:**

The second-order effects (or P-Δ effect) can be neglected in the case of buildings if the following condition is satisfied at all levels:

$$\theta = \frac{P_k \Delta_k}{V_k h_k} \leq 0.10$$

With:

- P<sub>k</sub>: total weight of the structure and operational loads associated above level k
- P<sub>k</sub> = ∑ (W<sub>gi</sub> + W<sub>qi</sub>)
- V<sub>k</sub>: floor shear force at level 'k'
- Δ<sub>k</sub>: relative displacement of level 'k' with respect to level 'k-1'
- h<sub>k</sub>: height of floor k
- If 0.10 < θ<sub>k</sub> ≤ 0.20, the P-Δ effects can be approximately accounted for by amplifying the effects of the seismic action calculated using a first-order elastic analysis by the factor 1/(1- θ<sub>k</sub>).
- If θ<sub>k</sub> > 0.20, the structure is potentially unstable and must be resized.

The calculation details of the coefficient θ are presented in the following tables.

**According to X :****Tab IV.24 : Justification regarding the P-Δ effect according to X.**

<b>Floor</b>	<b>Wi</b>	<b>Pk</b>	<b>ΔK</b>	<b>Vk</b>	<b>hk</b>	<b>θ</b>
<b>5</b>	487,71	487,71	1,2	121,175	306	0,0158

<b>4</b>	428,32	916,03	1,6	121,175	306	0,0395
<b>3</b>	428,32	1344,35	1,7	121,175	306	0,0616
<b>2</b>	428,32	1772,67	1,6	121,175	306	0,0765
<b>1</b>	428,32	2200,99	1,2	121,175	306	0,0712
<b>GF</b>	458,56	2659,55	0,8	121,175	306	0,0574

**According to Y :**

**Tab IV.25 : Justification regarding the P- $\Delta$  effect according to Y**

<b>Floor</b>	<b>Wi</b>	<b>Pk</b>	<b><math>\Delta K</math></b>	<b>Vk</b>	<b>hk</b>	<b><math>\theta</math></b>
<b>5</b>	487,71	487,71	0,3	116,687	306	0,004
<b>4</b>	487,71	916,03	0,3	116,687	306	0,007
<b>3</b>	487,71	1344,35	0,4	116,687	306	0,015
<b>2</b>	487,71	1772,67	0,4	116,687	306	0,019
<b>1</b>	487,71	2200,99	0,3	116,687	306	0,018
<b>GF</b>	487,71	2659,55	0,2	116,687	306	0,014

We have:  $\theta_i < 0.10$  for each level k and in both directions, therefore the P- $\Delta$  effect can be neglected in the calculation of structural elements.

## **IV.7 Conclusion:**

Dynamic analysis is the most important study in structural design as it is essential for defining the behavior of the structure in the event of an earthquake. This study helps us limit the damage to structural elements according to the Algerian seismic rules RPA 99/version 2003. Meeting all the requirements of dynamic analysis is not easy for all types of structures, as architectural constraints can hinder certain steps. Our structure is stable in the presence of seismic action.

## CHAPTER V

### REINFORCEMENT OF MAIN ELEMENTS

## Reinforcement of main elements

### V.1. Introduction :

The main elements are subjected to actions due to dead loads and live loads as well as seismic actions.

Their reinforcement must be made in such a way as to withstand the combinations of the different actions by considering the most unfavorable combinations.

Current regulations BAEL 91 and RPA 99 version 2003 dictate a number of combinations with which we will work.

- The beams are reinforced in simple bending.
- The posts are reinforced in compound bending.
- The sails are scraped in compound bending.

### V.2. The combinations of actions :

- **Regulation BAEL 21 :**

These are combination that take into account only dead loads G and the live loads Q.

$1.35G + 1.5 Q$  on U.L.S

$G + Q$  on S.L.S

- **Regulation RPA 99 (V2003) :**

These are combination that take into account account seismic loads E.

$G+Q\pm E$

$0.8G\pm E$

- **Mechanical characteristics of materials**

**Tab V.1 : Calculation data**

Situation durable		Situation accidental	
Concrete	Steel	Concrete	Steel
$\gamma_b = 1.5$	$\gamma_s = 1.15$	$\gamma_b = 1.15$	$\gamma_s = 1$
$f_{c28} = 25 \text{ MPA}$	$f_e = 400 \text{ MPA}$	$f_{c28} = 25 \text{ MPA}$	$f_e = 400 \text{ MPA}$

$f_{bc} = \frac{0.85 \times f_{c28}}{\theta \cdot \gamma_b}$ $= \frac{0.85 \times 25}{1 \times 1.5}$ $= 14.2 \text{ MPA}$	$\sigma_s = \frac{f_e}{\gamma_s}$ $= \frac{400}{1.15} = 348 \text{ MPA}$	$f_{bc} = \frac{0.85 \times f_{c28}}{\theta \cdot \gamma_b}$ $= \frac{0.85 \times 25}{1 \times 1.15}$ $= 18.48 \text{ MPA}$	$\sigma_s = \frac{f_e}{\gamma_s}$ $= \frac{400}{1} = 400 \text{ MPA}$
---	--	---	---

### V.3. Reinforcement beams :

The beams are scraped in single bending. The reinforcement is obtained in the ultimate limit state.

"ELU" under the effect of the most unfavorable solicitations in both directions and for both situations (durable and accidental).

#### □.3.1. Role of reinforced concrete beams :

Transmission of vertical loads resulting from the weight of the constituent elements the structure (walls, floors, stairs, etc.) as well as the operating structures of the different construction.

#### □.3.2. Recommendation :

##### a) Longitudinal reinforcement :

- Minimal reinforcement according to CBA 93 (condition of non-fragility) :

$$A_{smin} = \frac{0.23 b \cdot d \cdot f_{t28}}{f_e}$$

- Percentage of steels according to (RPA99/Version2003 Art 7.5.2.1) :

- The minimum total percentage of longitudinal steels along the entire length of the beam is 0.5% in any cross-section.
- The maximum total percentage of longitudinal steels is :
  - 4% in the current area.
  - 6% in the overlapping area.
- The minimum length of cover for Zone IIa is  $40\emptyset$ .
- The anchoring of the upper and lower longitudinal reinforcement in the edge and angle must be carried out with  $90^\circ$  hooks.
- The frames of the node arranged as transverse reinforcement of the posts, are made up of 2U superimposed forming a square or rectangle.

##### b) Transverse reinforcement :

- Verification of (RPA99/Version2003 Art 7.5.2.2) :

- The minimum quantity of transverse reinforcement is given by :  $A_t = 0.003 \cdot S_t \cdot b$   
With :  $b$  : Beam width.  
 $S_t$  : Maximum spacing between transverse reinforcement.
- The maximum spacing between the transverse reinforcement is determined as follows :
  - In the nodal zone and in the span if compressed reinforcement is required :

$$\text{minimum of } \left\{ \frac{h}{4} ; 12\emptyset \right\}$$

- Outside the nodal zone :  $S_t \leq \frac{h}{2}$
- The value of the diameter  $\emptyset_1$  of the longitudinal reinforcement to be taken is the smallest diameter used, and in the case of a span section with compressed reinforcement, it is the smallest diameter of compressed steels.
- The first transverse reinforcements must be placed at a distance of no more than 5 cm from the bare of the support or the embedment.

**c) Stress check :**

The rules of **CBA (Art 5.1)** considering the conventional tangent constraint or nominal as a state :  $\tau_u = \frac{V_u}{b \cdot d}$

It must be verified that :  $\tau_u < \overline{\tau_u}$

With :

$$\overline{\tau_u} = \begin{cases} \min \left\{ \frac{0.2 \times f_{c28}}{\gamma_b} ; 5 \text{ MPa} \right\} & \text{if Minimally damaging cracking} \\ \min \left\{ \frac{0.15 \times f_{c28}}{\gamma_b} ; 4 \text{ MPA} \right\} & \text{if Damaging or very damaging cracking} \end{cases}$$

#### V.4. Reinforcement of the main beams :

Les sollicitations de calcul sont tirées directement du logiciel Robot Structural Analyses Professional 2010.

**Tab V.2 : Summary of the loads for the main beams**

	ULS	SLS	ALS
The moment in the span (T.m)	4.70	3.43	5.90
The moment on the support (T.m)	-9.32	-6.79	-13.86

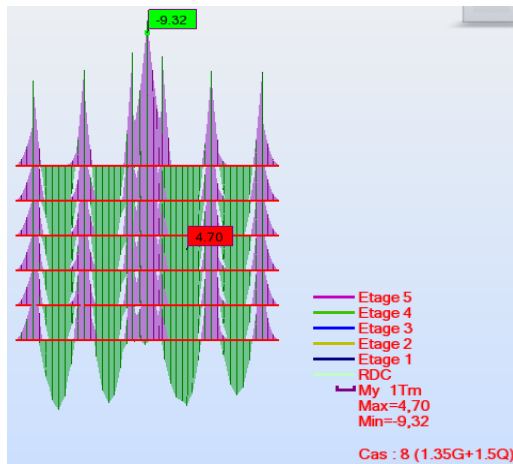

Figure V.1: Moment diagrams flexing  $M_y$  to the ULS

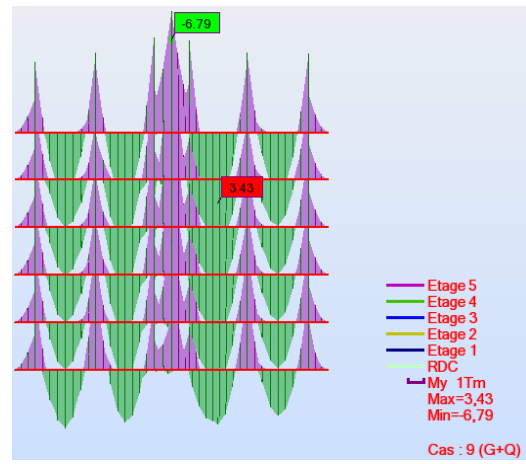

Figure V.2 : Moment diagrams flexing  $M_y$  to the SLS

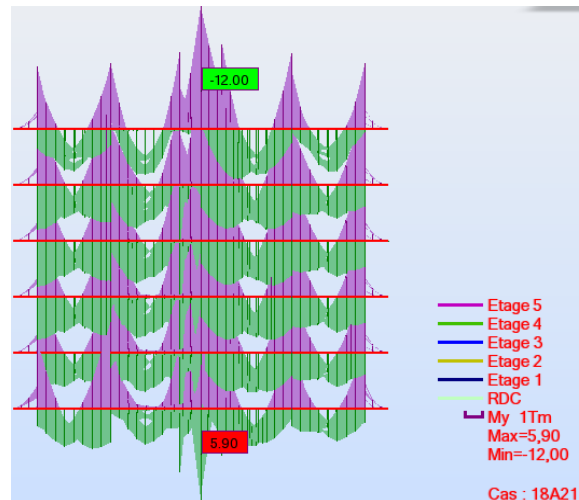
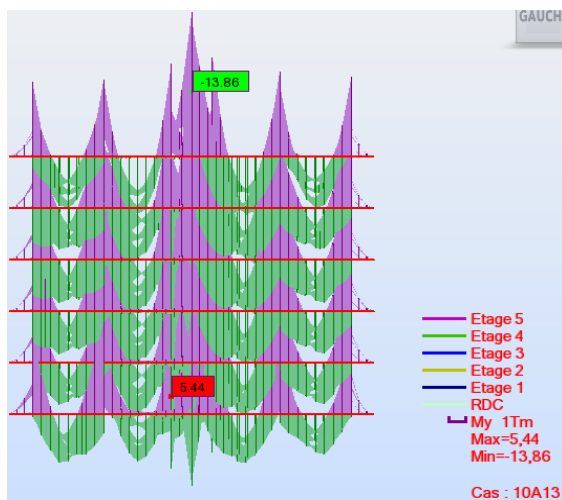

Figure V.3 : Moment diagram flexing  $M_y$  to the ALS

#### V.4.1. Longitudinal reinforcement :

The reinforcement is calculated in simple bending for a rectangular cross-section :

##### ➤ In span :

$$\text{U.L.S : } M_{\text{span}}^u = 4.70 \text{ T.m}$$

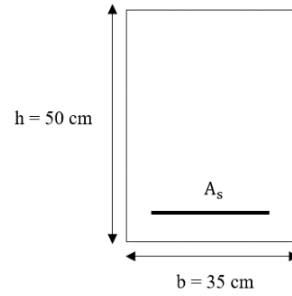

Figure V.4 : the design cross-section on span for the main beams

$$d = 0.9 \times h = 0.9 \times 0.50 = 0.45 \text{ m}$$

$$\mu = \frac{M_{\text{span}}^u}{b \cdot d^2 \cdot f_{bc}} = \frac{4.70 \times 10^{-2}}{0.35 \times 0.42^2 \times 14.2} = 0.047 < \mu_{\text{limit}} = 0.391 \rightarrow A' = 0$$

$$\mu = 0.047 < 0.186 \rightarrow \text{pivot } A$$

$$\alpha_u = 1.25 \times (1 - \sqrt{1 - 2\mu}) = 1.25 \times (1 - \sqrt{1 - 2 \times 0.047}) = 0.060$$

$$A_s = 0.8 \cdot \alpha_u \cdot b \cdot d \cdot \frac{f_{bc}}{\sigma_s} = \frac{0.8 \times 0.060 \times 0.35 \times 0.45 \times 14.2}{348} = 3.084 \times 10^{-4} \text{ m}^2$$

$$= 3.084 \text{ cm}^2$$

$$\text{ALS : } M_{\text{span}}^{\text{acc}} = 5.90 \text{ T.m}$$

$$\mu = \frac{M_{\text{span}}^{\text{acc}}}{b \cdot d^2 \cdot f_{bc}} = \frac{5.92 \times 10^{-2}}{0.35 \times 0.42^2 \times 18.48} = 0.045 < \mu_{\text{limit}} = 0.391 \rightarrow A' = 0$$

$$\mu = 0.045 < 0.186 \rightarrow \text{pivot } A$$

$$\alpha_u = 1.25 \times (1 - \sqrt{1 - 2\mu}) = 1.25 \times (1 - \sqrt{1 - 2 \times 0.045}) = 0.057$$

$$A_s = 0.8 \cdot \alpha_u \cdot b \cdot d \cdot \frac{f_{bc}}{\sigma_s} = \frac{0.8 \times 0.057 \times 0.35 \times 0.45 \times 18.48}{400} = 3.32 \times 10^{-4} \text{ m}^2$$

$$= 3.32 \text{ cm}^2$$

$$A_s = \max\{3.087 \text{ cm}^2 ; 3.32 \text{ cm}^2\} = 3.32 \text{ cm}^2$$

➤ **In support :**

$$\text{ULS : } M_{\text{support}}^u = 9.32 \text{ T.m}$$

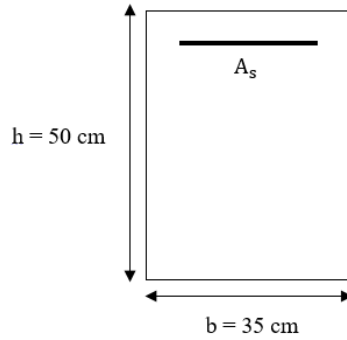

Figure V.5 : the design cross-section on supports for the main beams

$$\mu = \frac{M_{\text{support}}^u}{b \cdot d^2 \cdot f_{bc}} = \frac{9.32 \times 10^{-2}}{0.35 \times 0.42^2 \times 14.2} = 0.092 < \mu_{\text{limit}} = 0.391 \rightarrow A' = 0$$

$$\mu = 0.092 < 0.186 \rightarrow \text{pivot } A$$

$$\alpha_u = 1.25 \times (1 - \sqrt{1 - 2\mu}) = 1.25 \times (1 - \sqrt{1 - 2 \times 0.092}) = 0.120$$

$$A_s = 0.8 \cdot \alpha_u \cdot b \cdot d \cdot \frac{f_{bc}}{\sigma_s} = \frac{0.8 \times 0.120 \times 0.35 \times 0.45 \times 14.2}{348} = 6.16 \times 10^{-4} \text{m}^2 = 6.16 \text{ cm}^2$$

**ALS :**  $M_{\text{support}}^{\text{acc}} = 13.86 \text{ T.m}$

$$\mu = \frac{M_{\text{support}}^{\text{acc}}}{b \cdot d^2 \cdot f_{bc}} = \frac{13.86 \times 10^{-2}}{0.35 \times 0.42^2 \times 18.48} = 0.105 < \mu_{\text{limit}} = 0.391 \rightarrow A' = 0$$

$$\mu = 0.105 < 0.186 \rightarrow \text{pivot } A$$

$$\alpha_u = 1.25 \times (1 - \sqrt{1 - 2\mu}) = 1.25 \times (1 - \sqrt{1 - 2 \times 0.105}) = 0.138$$

$$A_s = 0.8 \cdot \alpha_u \cdot b \cdot d \cdot \frac{f_{bc}}{\sigma_s} = \frac{0.8 \times 0.138 \times 0.35 \times 0.45 \times 18.48}{400} = 8.03 \times 10^{-4} \text{m}^2$$

$$= 8.03 \text{ cm}^2$$

$$A_s = \max\{6.16 \text{ cm}^2 ; 8.03 \text{ cm}^2\} = 8.03 \text{ cm}^2$$

**V.4.2. Verification required :**

- Non-frailty condition : .... (CBA93 Art A.4.2)

It is necessary to check that:  $A_s \geq A_{s \text{ min}}$

$$A_{s \text{ min}} = \frac{0.23 \cdot b \cdot d \cdot f_{t28}}{f_e} = \frac{0.23 \times 0.35 \times 0.45 \times 2.1}{400} = 1.90 \times 10^{-4} \text{m}^2 = 1.90 \text{ cm}^2$$

$$A_{s \text{ span}} = 3.32 \text{ cm}^2 > A_{s \text{ min}} = 1.90 \text{ cm}^2 \dots\dots\dots \text{CV}$$

$$A_{s \text{ support}} = 8.03 \text{ cm}^2 > A_{s \text{ min}} = 1.90 \text{ cm}^2 \dots\dots\dots \text{CV}$$

So : we take :  $A_{s \text{ span}} = 3\text{HA}14 = 4.62 \text{ cm}^2$

And :  $A_{s \text{ support}} = 6\text{HA}14 = 9.24 \text{ cm}^2$

- Verification of longitudinal reinforcement according to the (RPA 99/V2003 Art 7.5.2.1) :

→ The minimum total percentage of longitudinal steels along the entire length of the beam is 0.5% in any section.

$$A_{\text{min RPA}} = 0.5\% b h = 0.005 \times 35 \times 50 = 8.75 \text{ cm}^2$$

$$A_s = 3\text{HA}14 + 6\text{HA}14 = 13.86 \text{ cm}^2$$

$$A_s = 13.86 \text{ cm}^2 > A_{\text{min}} = 8.75 \text{ cm}^2 \dots\dots\dots\text{CV}$$

→ The maximum total percentage of longitudinal steels is :

❖ Current area :

$$A_{s \text{ max RPA}} = 4\% b h = 0.04 \times 35 \times 50 = 70 \text{ cm}^2$$

$$A_{s \text{ span}} = 3\text{HA}14 + 6\text{HA}14 = 13.86 \text{ cm}^2$$

$$A_{s \text{ span}} = 13.86 \text{ cm}^2 < A_{\text{max}} = 70 \text{ cm}^2 \dots\dots\dots\text{CV}$$

❖ Overlay area :

$$A_{s \text{ max RPA}} = 6\% b h = 0.06 \times 35 \times 50 = 105 \text{ cm}^2$$

$$A_s = 3\text{HA}14 + 6\text{HA}14 = 13.86 \text{ cm}^2$$

$$A_{s \text{ span}} = 13.86 \text{ cm}^2 < A_{\text{max}} = 105 \text{ cm}^2 \dots\dots\dots\text{CV}$$

→ The minimum length of cover for Zone IIa is :

$$L_{\text{collection}} = 40\emptyset = 40 \times 1.4 = 56 \text{ cm} \quad \text{we take : } 60 \text{ cm}$$

- Verification S.L.S :

$$\alpha \leq \frac{\gamma - 1}{2} + \frac{f_{c28}}{100}$$

**ULS :**

**In span :**

$$\alpha = 0.060$$

$$\gamma = \frac{M_{\text{span}}^u}{M_{\text{span}}^{\text{ser}}} = \frac{4.70}{3.43} = 1.37$$

$$\alpha = 0.060 \leq \frac{1.37-1}{2} + \frac{25}{100} = 0.44 \dots\dots\dots\text{CV}$$

**In support :**

$$\alpha = 0.120$$

$$\gamma = \frac{M_{\text{support}}^u}{M_{\text{support}}^{\text{ser}}} = \frac{9.32}{6.79} = 1.37$$

$$\alpha = 0.120 \leq \frac{1.37-1}{2} + \frac{25}{100} = 0.44 \dots\dots\dots\text{CV}$$

**A.L.S :**

**In span :**

$$\alpha = 0.057$$

$$\gamma = \frac{M_{\text{span}}^{\text{acc}}}{M_{\text{span}}^{\text{ser}}} = \frac{5.90}{3.43} = 1.72$$

$$\alpha = 0.057 \leq \frac{1.72-1}{2} + \frac{25}{100} = 0.61 \dots\dots\dots\text{CV}$$

**In support :**

$$\alpha = 0.137$$

$$\gamma = \frac{M_{\text{support}}^{\text{acc}}}{M_{\text{support}}^{\text{ser}}} = \frac{13.86}{6.79} = 2.04$$

$$\alpha = 0.137 \leq \frac{2.04-1}{2} + \frac{25}{100} = 0.77 \dots\dots\dots\text{CV}$$

- Verification of the shear condition :(CBA93 Art A.5.1)

**Minimally damaging cracking**

It must be checked that :  $\tau_u < \bar{\tau}_u$

$$T_u = 10.55 \text{ T. m}$$

$$\tau_u = \frac{T_u}{b \cdot d} = \frac{10.55 \times 10^{-2}}{0.35 \times 0.45} = 0.669 \text{ MN. m}$$

$$\bar{\tau}_u = \min \left\{ \frac{0.2 \times f_{c28}}{\gamma_b} ; 5 \text{ MPa} \right\} = \min \left\{ \frac{0.2 \times 25}{1.5} = 3.33 \text{ MPa} ; 5 \text{ MPa} \right\}$$

$$\bar{\tau}_u = 3.33 \text{ MPa}$$

$$0.669 \text{ MPa} < 3.33 \text{ MPa} \dots\dots\dots\text{CV}$$

**V.4.3. Transverse reinforcement :**

Diameter : You have to check :  $\emptyset_{\text{tr}} \leq \min \left\{ \frac{h}{35} ; \frac{b}{10} ; \emptyset_1 \right\}$

$$\emptyset_{\text{tr}} \leq \min \left\{ \frac{50}{35} ; \frac{35}{10} ; 1.4 \right\}$$

$$\emptyset_{\text{tr}} \leq \min \{ 1.42 ; 3.5 ; 1.4 \} = 1.4 \text{ cm} = 14 \text{ mm} \rightarrow \text{ we take : } \emptyset_{\text{tr}} = 8 \text{ mm}$$

Spacing :

**Nodal area :**

$$S_t \leq \min \left\{ \frac{h}{4} ; 12\phi_1 \right\}$$

$$S_t \leq \min \left\{ \frac{50}{4} = 12.5 \text{ cm} ; 12 \times 1.4 = 16.8 \text{ cm} \right\} = 12.5 \text{ cm}$$

We take :  $S_t = 10 \text{ cm}$

**Current area :**

$$S_t \leq \frac{h}{2} = \frac{50}{2} = 25 \text{ cm}$$

We take :  $S_t = 15 \text{ cm}$

La section d'armatures transversales :

**Nodal area :**

$$A_t \geq 0.3\% S b$$

$$A_t \geq 0.003 \times 10 \times 35 = 1.05 \text{ cm}^2$$

**Current area :**

$$A_t \geq 0.3\% S b$$

$$A_t \geq 0.003 \times 15 \times 35 = 1.57 \text{ cm}^2$$

We take :  $A_t = 4T8 = 2.01 \text{ cm}^2$

$$A_{t \text{ adopt}} = 2.01 \text{ cm}^2 > A_{t \text{ calc}} = 1.05 \text{ cm}^2 \dots\dots\dots \text{CV}$$

$$A_{t \text{ adopt}} = 2.01 \text{ cm}^2 > A_{t \text{ calc}} = 1.57 \text{ cm}^2 \dots\dots\dots \text{CV}$$

#### **V.4.4. Checking the Arrow :**

It is not necessary to proceed with the calculation of the deflection if the beams

considered meet the following conditions :  $\frac{h}{L} \geq \frac{1}{6}$  ;  $\frac{A_s \text{ span}}{bd} \leq \frac{4.2}{f_e}$  ;  $\frac{h}{L} \geq \frac{M_{\text{span}}^{\text{ser}}}{10M_o^{\text{ser}}}$

With :  $M_t = K \times M_o$

K : is a reduction coefficient ( $0,75 \leq K \leq 0,85$ ) we adopt  $K = 0.8$

$$\frac{h}{L} \geq \frac{1}{6} \Rightarrow \frac{50}{505} \geq \frac{1}{6} \Rightarrow 0.09 > 0.06 \dots \text{CV}$$

$$\frac{A_s \text{ span}}{bd} \leq \frac{4.2}{f_e} \Rightarrow \frac{4.62}{35 \times 45} \leq \frac{4.2}{400} \Rightarrow 0.00293 < 0.0105 \dots \text{CV}$$

$$\frac{h}{L} \geq \frac{M_{\text{span}}^{\text{ser}}}{10M_0^{\text{ser}}} \Rightarrow \frac{50}{505} \geq \frac{3.43}{10 \times 4.28} \Rightarrow 0.09 > 0.08 \dots \text{CV}$$

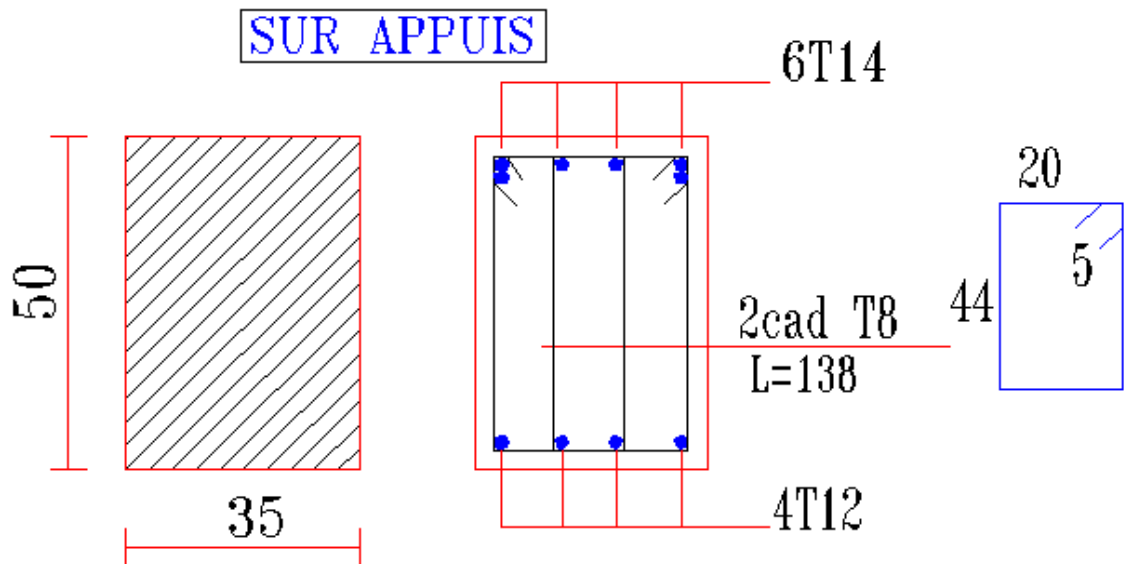
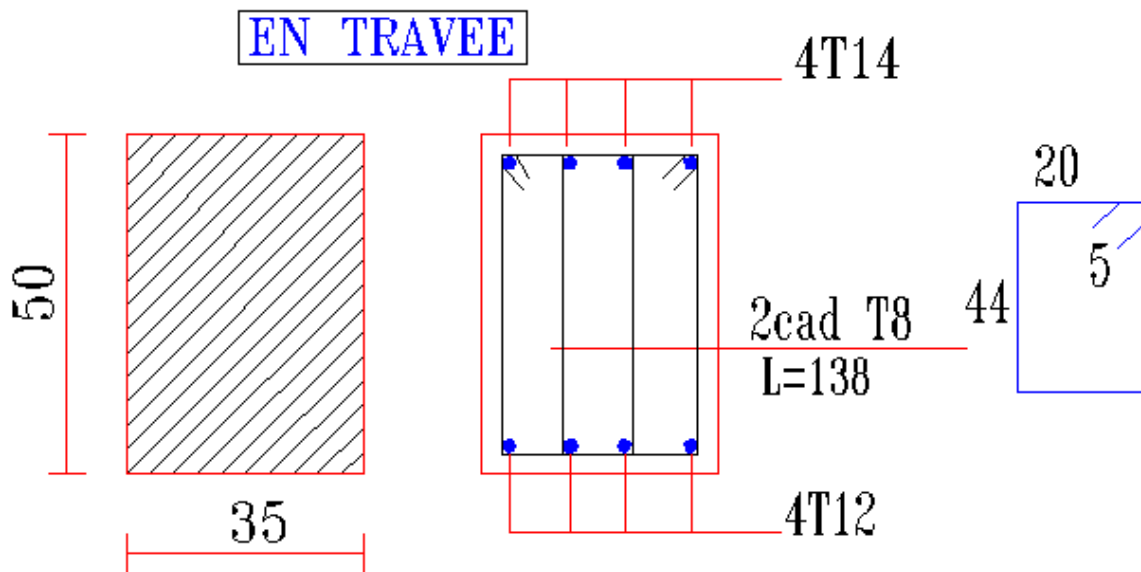
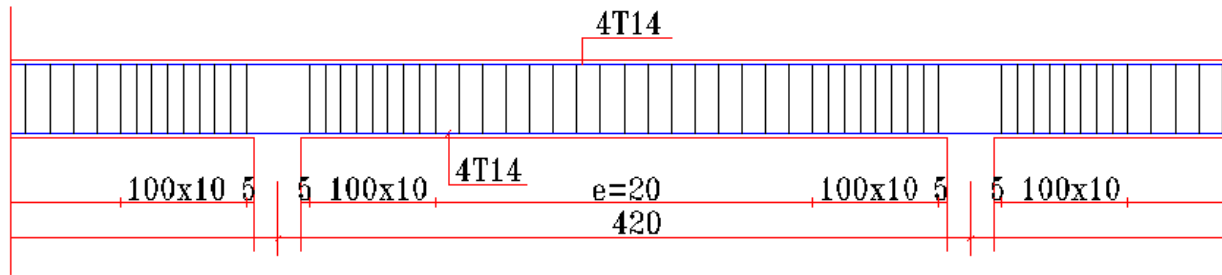

Figure V.6.: Main beam reinforcement

## V.5. Reinforcement of secondary beams :

Les sollicitations de calcul sont tirées directement du logiciel Robot Structural Analyses Professional 2010.

Tab V.3. Summary of loads for beams Secondary.

	ULS	SLS	ALS
The moment in the span (T.m)	2.48	1.80	6.36
The moment on the support (T.m)	-3.82	-2.78	-7.78

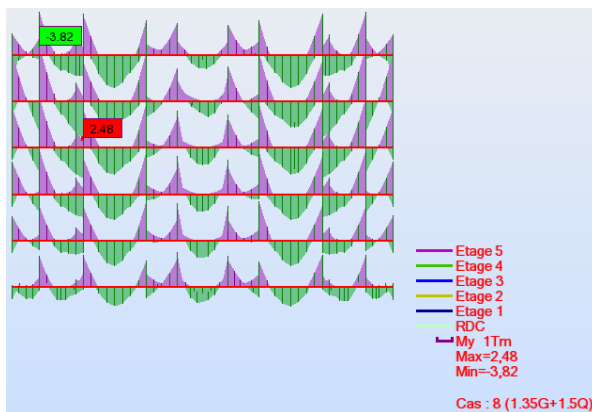

Figure V.7 : Moment diagrams flexing My to the ULS

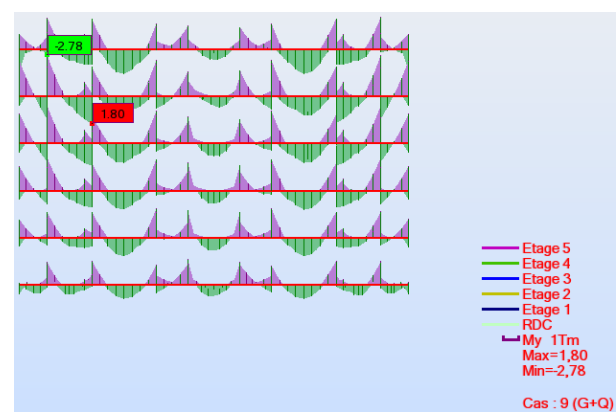

Figure V.8 : Moment diagrams flexing My to the SLS

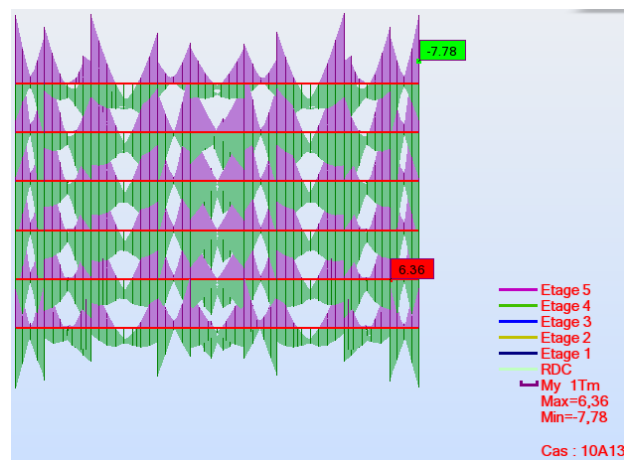

Figure V.9 : Moment diagrams flexing My to the ALS

### V.5.1. Longitudinal reinforcement :

The reinforcement is calculated in simple bending for a rectangular cross-section :

➤ **In span :**

$$\text{U.L.S : } M_{\text{span}}^u = 2.78 \text{ T.m}$$

$$\text{A.L.S : } M_{\text{span}}^{\text{acc}} = 6.36 \text{ T.m}$$

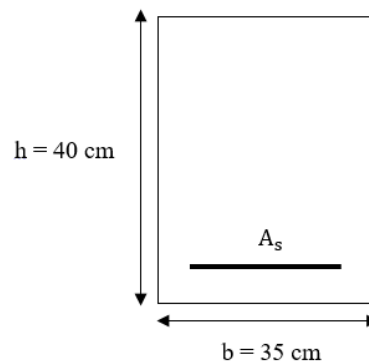

Figure V.10 : The span desing cross-section for secondary beams

$$d = 0.9 \times h = 0.9 \times 0.40 = 0.36 \text{ m}$$

Tab V.4 : Design note for secondary beams in span.

	$\mu$	$\alpha_u$	$A_s$
<b>ULS</b>	$\mu = \frac{M_{\text{span}}^u}{b \cdot d^2 \cdot f_{bc}}$ $= \frac{2.48 \times 10^{-2}}{0.35 \times 0.36^2 \times 14.2} = 0.038$ $\mu < \mu_{\text{limit}} = 0.391 \rightarrow A' = 0$ $\mu = 0.047 < 0.186 \rightarrow \text{pivot } A$	$1.25 \times (1 - \sqrt{1 - 2\mu})$ $\alpha_u = 0.048$	$A_s = \frac{0.8 \times \alpha_u \times b \times d \times f_{bc}}{\sigma_s}$ $A_s = 1.97 \times 10^{-4} \text{ m}^2$ $A_s = 1.97 \text{ cm}^2$
<b>ALS</b>	$\mu = \frac{M_{\text{span}}^{\text{acc}}}{b \cdot d^2 \cdot f_{bc}}$ $= \frac{6.36 \times 10^{-2}}{0.35 \times 0.36^2 \times 18.48} = 0.075$ $\mu < \mu_{\text{limit}} = 0.391 \rightarrow A' = 0$ $\mu = 0.075 < 0.186 \rightarrow \text{pivot } A$	$1.25 \times (1 - \sqrt{1 - 2\mu})$ $\alpha_u = 0.097$	$A_s = \frac{0.8 \times \alpha_u \times b \times d \times f_{bc}}{\sigma_s}$ $A_s = 4.51 \times 10^{-4} \text{ m}^2$ $A_s = 4.51 \text{ cm}^2$

$$A_s = \max\{1.97 \text{ cm}^2 ; 4.51 \text{ cm}^2\} = 4.51 \text{ cm}^2$$

➤ **In support :**

$$\text{ULS : } M_{\text{support}}^u = 3.82 \text{ T.m}$$

$$\text{ALS : } M_{\text{support}}^{\text{acc}} = 7.78 \text{ T.m}$$

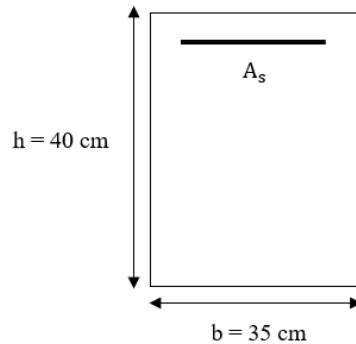

Figure V.11 : the support desing cross-section for secondary beams

Tab V.5 : Design note for secondary beams in support

	$\mu$	$\alpha_u$	$A_s$
<b>ULS</b>	$\mu = \frac{M_{\text{support}}^u}{b \cdot d^2 \cdot f_{bc}}$ $= \frac{3.82 \times 10^{-2}}{0.35 \times 0.36^2 \times 14.2} = 0.059$ $\mu < \mu_{\text{limit}} = 0.391 \rightarrow A' = 0$ $\mu = 0.059 < 0.186 \rightarrow \text{pivot A}$	$1.25 \times (1 - \sqrt{1 - 2\mu})$ $\alpha_u = 0.076$	$A_s = \frac{0.8 \times \alpha_u \times b \times d \times f_{bc}}{\sigma_s}$ $A_s = 3.12 \times 10^{-4} \text{ m}^2$ $A_s = 3.12 \text{ cm}^2$
<b>ALS</b>	$\mu = \frac{M_{\text{support}}^{\text{acc}}}{b \cdot d^2 \cdot f_{bc}}$ $= \frac{7.78 \times 10^{-2}}{0.35 \times 0.36^2 \times 18.48} = 0.092$ $\mu < \mu_{\text{limit}} = 0.391 \rightarrow A' = 0$ $\mu = 0.092 < 0.186 \rightarrow \text{pivot A}$	$1.25 \times (1 - \sqrt{1 - 2\mu})$ $\alpha_u = 0.120$	$A_s = \frac{0.8 \times \alpha_u \times b \times d \times f_{bc}}{\sigma_s}$ $A_s = 5.58 \times 10^{-4} \text{ m}^2$ $A_s = 5.58 \text{ cm}^2$

$$A_s = \max\{3.12 \text{ cm}^2 ; 5.58 \text{ cm}^2\} = 5.58 \text{ cm}^2$$

**V.5.2. Verification required :**

- Non-frailty condition : .... (CBA93 Art A.4.2)

It is necessary to check that:  $A_s \geq A_{s \min}$

$$A_{s \min} = \frac{0.23 \cdot b \cdot d \cdot f_{t28}}{f_e} = \frac{0.23 \times 0.35 \times 0.36 \times 2.1}{400} = 1.52 \times 10^{-4} \text{m}^2 = 1.52 \text{ cm}^2$$

$$A_{s \text{ span}} = 4.51 \text{ cm}^2 > A_{s \min} = 1.90 \text{ cm}^2 \dots\dots\dots \text{CV}$$

$$A_{s \text{ support}} = 5.58 \text{ cm}^2 > A_{s \min} = 1.90 \text{ cm}^2 \dots\dots\dots \text{CV}$$

So : we take :  $A_{s \text{ span}} = 4\text{HA}12 = 4.52 \text{ cm}^2$

And :  $A_{s \text{ support}} = 4\text{HA}14 = 6.16 \text{ cm}^2$

- Verification of longitudinal reinforcement according to the (RPA 99/V2003 Art 7.5.2.1) :

→ The minimum total percentage of longitudinal steels along the entire length of the beam is 0.5% in any section.

$$A_{\min \text{ RPA}} = 0.5\% \text{ b h} = 0.005 \times 35 \times 40 = 7 \text{ cm}^2$$

$$A_s = 4\text{HA}12 + 4\text{HA}14 = 10.68 \text{ cm}^2$$

$$A_s = 10.68 \text{ cm}^2 > A_{\min} = 7 \text{ cm}^2 \dots\dots\dots \text{CV}$$

→ The maximum total percentage of longitudinal steels is :

❖ Current area :

$$A_{s \max \text{ RPA}} = 4\% \text{ b h} = 0.04 \times 35 \times 40 = 56 \text{ cm}^2$$

$$A_{s \text{ span}} = 4\text{HA}12 + 4\text{HA}14 = 10.68 \text{ cm}^2$$

$$A_{s \text{ span}} = 10.68 \text{ cm}^2 < A_{\max} = 56 \text{ cm}^2 \dots\dots\dots \text{CV}$$

❖ Overlay area :

$$A_{s \max RPA} = 6\% b h = 0.06 \times 35 \times 40 = 84 \text{ cm}^2$$

$$A_s = 4HA12 + 4HA14 = 10.68 \text{ cm}^2$$

$$A_{s \text{ span}} = 10.68 \text{ cm}^2 < A_{\max} = 84 \text{ cm}^2 \dots\dots\dots CV$$

→ The minimum length of cover for Zone IIa is :

$$L_{\text{collection}} = 40\emptyset = 40 \times 1.4 = 56 \text{ cm} \quad \text{we take : } 60 \text{ cm}$$

- Verification S.L.S :

$$\alpha \leq \frac{\gamma - 1}{2} + \frac{f_{c28}}{100}$$

**ULS :**

**In span :**

$$\alpha = 0.048$$

$$\gamma = \frac{M_{\text{span}}^u}{M_{\text{span}}^{\text{ser}}} = \frac{2.48}{1.80} = 1.38$$

$$\alpha = 0.048 \leq \frac{1.38-1}{2} + \frac{25}{100} = 0.43 \dots\dots\dots CV$$

**In support :**

$$\alpha = 0.076$$

$$\gamma = \frac{M_{\text{support}}^u}{M_{\text{support}}^{\text{ser}}} = \frac{3.82}{2.78} = 1.37$$

$$\alpha = 0.120 \leq \frac{1.37-1}{2} + \frac{25}{100} = 0.44 \dots\dots\dots CV$$

**ALS :**

**In span :**

$$\alpha = 0.097$$

$$\gamma = \frac{M_{\text{span}}^{\text{acc}}}{M_{\text{span}}^{\text{ser}}} = \frac{6.36}{1.80} = 3.53$$

$$\alpha = 0.057 \leq \frac{1.72-1}{2} + \frac{25}{100} = 1.51 \dots \text{CV}$$

**In support :**

$$\alpha = 0.120$$

$$\gamma = \frac{M_{\text{support}}^{\text{acc}}}{M_{\text{support}}^{\text{ser}}} = \frac{7.78}{2.78} = 2.79$$

$$\alpha = 0.120 \leq \frac{2.79-1}{2} + \frac{25}{100} = 1.14 \dots \text{CV}$$

- Verification of the shear condition : (CBA93 Art A.5.1)

### Minimally damaging cracking

It must be checked that :  $\tau_u < \bar{\tau}_u$

$$T_u = 5.64 \text{ T.M}$$

$$\tau_u = \frac{T_u}{b \cdot d} = \frac{5.64 \times 10^{-2}}{0.35 \times 0.36} = 0.447 \text{ MN.m}$$

$$\bar{\tau}_u = \min \left\{ \frac{0.2 \times f_{c28}}{\gamma_b} ; 5 \text{ MPa} \right\} = \min \left\{ \frac{0.2 \times 25}{1.5} = 3.33 \text{ MPa} ; 5 \text{ MPa} \right\}$$

$$\bar{\tau}_u = 3.33 \text{ MPa}$$

$$0.447 \text{ MPa} < 3.33 \text{ MPa} \dots \text{CV}$$

### V.5.3. Transverse reinforcement :

Diameter : You have to check :  $\emptyset_{\text{tr}} \leq \min \left\{ \frac{h}{35} ; \frac{b}{10} ; \emptyset_1 \right\}$

$$\emptyset_{\text{tr}} \leq \min \left\{ \frac{40}{35} ; \frac{35}{10} ; 1.4 \right\}$$

$$\emptyset_{\text{tr}} \leq \min \{ 1.14 ; 3.5 ; 1.4 \} = 1.14 \text{ cm} = 11.4 \text{ mm} \quad \rightarrow \quad \text{we take : } \emptyset_{\text{tr}} = 8 \text{ mm}$$

Spacing :

**Nodal area :**

$$S_t \leq \min \left\{ \frac{h}{4} ; 12\phi_1 \right\}$$

$$S_t \leq \min \left\{ \frac{40}{4} = 10 \text{ cm} ; 12 \times 1.4 = 16.8 \text{ cm} \right\} = 10 \text{ cm}$$

We take :  $S_t = 10 \text{ cm}$

**Current area :**

$$S_t \leq \frac{h}{2} = \frac{40}{2} = 20 \text{ cm}$$

We take :  $S_t = 15 \text{ cm}$

**The section of transverse reinforcements:**

**Nodal area :**

$$A_t \geq 0.3\% S b$$

$$A_t \geq 0.003 \times 10 \times 0.35 = 1.05 \text{ cm}^2$$

**Current area :**

$$A_t \geq 0.3\% S b$$

$$A_t \geq 0.003 \times 15 \times 0.35 = 1.57 \text{ cm}^2$$

We take :  $A_t = 4T8 = 2.01 \text{ cm}^2$

$$A_{t \text{ adopt}} = 2.01 \text{ cm}^2 > A_{t \text{ calc}} = 1.05 \text{ cm}^2 \dots\dots\dots CV$$

$$A_{t \text{ adopt}} = 2.01 \text{ cm}^2 > A_{t \text{ calc}} = 1.57 \text{ cm}^2 \dots\dots\dots CV$$

### V.5.4. Checking the Arrow :

It is not necessary to proceed with the calculation of the deflection if the beams considered

meet the following conditions :  $\frac{h}{L} \geq \frac{1}{6}$  ;  $\frac{A_s \text{ span}}{bd} \leq \frac{4.2}{f_e}$  ;  $\frac{h}{L} \geq \frac{M_{\text{span}}^{\text{ser}}}{10M_0^{\text{ser}}}$

With :  $M_t = K \times M_0$

K : is a reduction coefficient ( $0,75 \leq K \leq 0,85$ ) we adopt  $K = 0.8$

$$\frac{h}{L} \geq \frac{1}{6} \quad \Rightarrow \quad \frac{40}{420} \geq \frac{1}{6} \quad \Rightarrow \quad 0.095 > 0.06 \dots \dots \dots \text{CV}$$

$$\frac{A_s \text{ span}}{bd} \leq \frac{4.2}{f_e} \quad \Rightarrow \quad \frac{4.52}{35 \times 36} \leq \frac{4.2}{400} \quad \Rightarrow \quad 0.00358 < 0.0105 \dots \dots \dots \text{CV}$$

$$\frac{h}{L} \geq \frac{M_{\text{span}}^{\text{ser}}}{10M_0^{\text{ser}}} \quad \Rightarrow \quad \frac{40}{420} \geq \frac{1.80}{10 \times 2.25} \quad \Rightarrow \quad 0.09 \geq 0.08 \dots \dots \dots \text{CV}$$

□.6. Reinforcement of the columns:

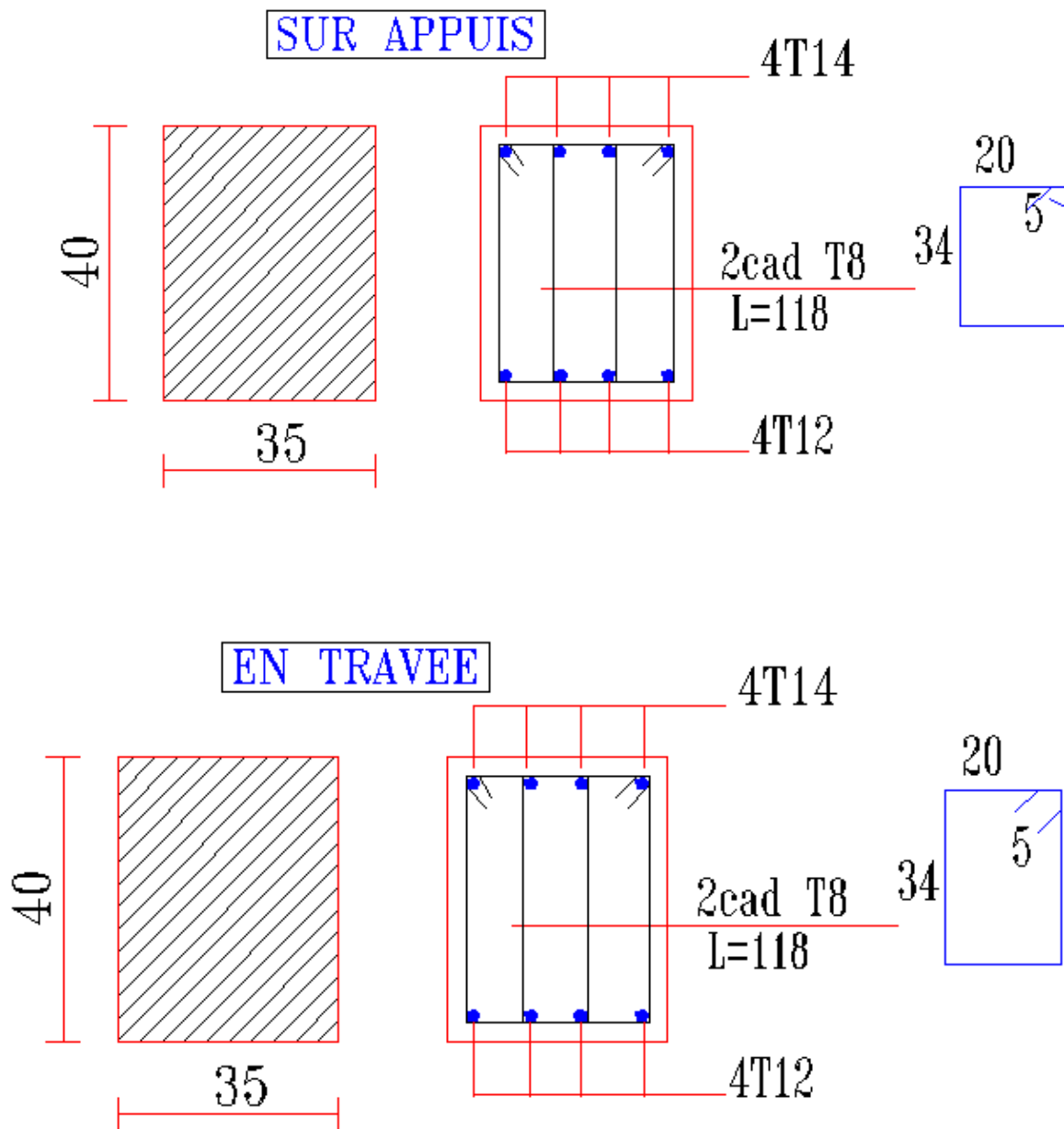
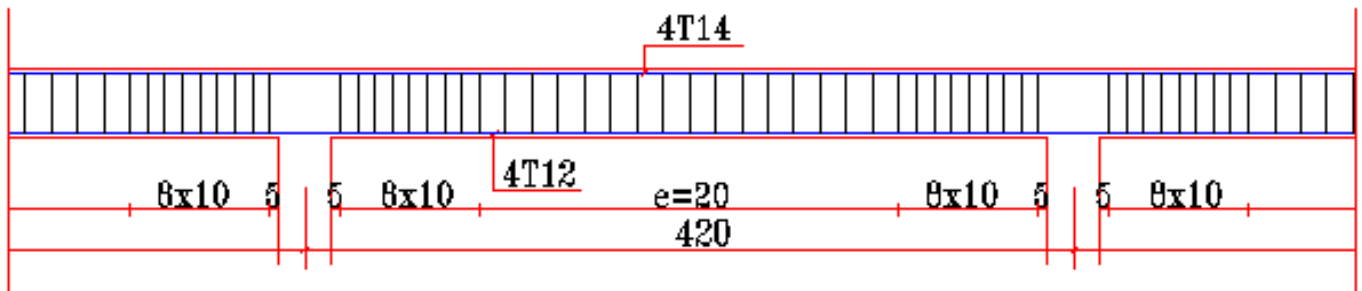

Figure V.12 : Diagram of the reinforcement of the secondary beams

## □.6. the columns :

### V.6.1 Introduction :

The columns are structural elements ensuring the transmission of forces from the beams to the foundations, and are subjected to a normal force "N" and a bending moment "M" in both directions: longitudinal and transverse. So they are calculated in compound bending.

### V.6.2. Roles of reinforced concrete columns :

1. Constitute the load-bearing elements of the column-beam system by isolated support points.
2. Supporting vertical loads (compressive force in columns).
3. Participates in transverse stability (column-beam system) to combat stress horizontal (winds, earthquake, expansion).
4. Vertical bargain hunting service.

### V.6.3. Solicitations to consider :

The calculations are made taking into account three types of solicitation :

1. Maximum Normal Effort ( $N_{\max}$ ) and the corresponding moment ( $M_{\text{corresponding}}$ ).
2. Minimal normal effort ( $N_{\min}$ ) and the corresponding moment ( $M_{\text{corresponding}}$ ).
3. Maximum Bending Moment ( $M_{\max}$ ) and the corresponding normal effort ( $N_{\text{corresponding}}$ ).

$$N_{\max} \rightarrow M_{\text{corresponding}} \rightarrow A_1$$

$$N_{\min} \rightarrow M_{\text{corresponding}} \rightarrow A_2 \rightarrow A = \max(A_1 ; A_2 ; A_3)$$

$$M_{\max} \rightarrow N_{\text{corresponding}} \rightarrow A_3$$

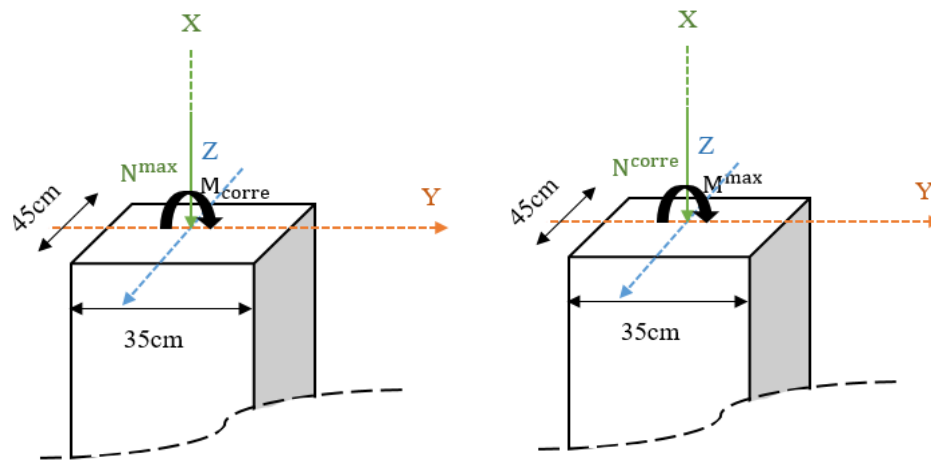

Figure V.13: solicitation of a column

A section subjected to compound bending can occur in one of three cases Following :

- **Partially compressed cross-section :**
  - If the normal force is a compressive force, the center of pressure is outside the section.
  - If the normal force is compressive, the centre of pressure is inside the section and  $e > \frac{h}{6}$
- **Fully compressed section :**
  - A section is said to be fully compressed if the center of pressure is inside the central core  $e < \frac{h}{6}$  of the total cross-section made homogeneous.
- **Fully tensioned section :**
  - A section is fully tensioned if the normal force is a tensile force and the centre of pressure is between the two reinforcement marks.

#### V.6.4. Recommendations :

a) According to RPA99 version 2003 :

- **Longitudinal reinforcement: (Art 7.4.2.1)**

Longitudinal reinforcement must be high-adhesion, straight and without hooks :

→ Their minimum percentage will be: 0.8% in zone Iia

→ Their maximum percentage will be :

1. 3% in the current area.
2. 6% in the overlapping area.

→ Minimum diameter is 12 mm.

→ The minimum length of the covers is :  $40\emptyset$  in zone Iia.

→ The distance between the vertical bars in one face of the post must not exceed 25 m in zone Iia

→ The height of the nodal zone :  $h' = \max \left\{ \frac{h_e}{6} ; b ; h ; 60 \text{ cm} \right\}$

▪ **Transverse reinforcement :**

- The transverse reinforcement of the columns is calculated using the formula :

$$\frac{A_t}{S_t} = \frac{\rho_a V_u}{h f_e}$$

With :

$V_u$  : Calculation Cutting Force.

$h_e$  : Total height of the gross section.

$f_e$  : Elastic Stress of Transverse Reinforcing Steel.

$\rho_a$  : Correction coefficient which takes into account the brittle mode of fracture by shear force,

it is taken equal to :  $\begin{cases} \rho_a = 2.5 & \text{if : } \lambda_g > 5 \\ \rho_a = 3.75 & \text{if : } \lambda_g \leq 5 \end{cases}$

- Maximum spacing of transverse reinforcement :

→ In the nodal area :  $S_t \leq \min \{ 10\emptyset_1 ; 15 \text{ cm} \}$

→ In the current area :  $S_t \leq 15\emptyset_1$

- $\emptyset_1$  : Minimum diameter of longitudinal column reinforcement.

- $\lambda_g : \lambda_g = \frac{L_f}{a} \text{ or } \frac{L_f}{b}$

- Minimum amount of transverse reinforcement  $\frac{A_t}{S_t \cdot b}$  in % is given as follows:

- If :  $\lambda_g \geq 5 \frac{A_t}{S_t \cdot b} = 0.3\%$

- If :  $\lambda_g \geq 3 \frac{A_t}{S_t \cdot b} = 0.8\%$

- If :  $3 < \lambda_g < 5$  interpolate between previous limit values

$\lambda_g$  : is the geometric slenderness of the column  $\lambda_g = \frac{L_f}{a}$  or  $\frac{L_f}{b}$

b) According to : CBA 93 (Art A.4.3.5)

- **Calculating eccentricity** : Case of compound bending with compression

Sections subjected to normal compressive stress shall be justified with respect to the limit-ultimate state of shape stability by replacing the actual eccentricity :

$$e_1 = \frac{M_u}{N_u} \text{ (in compound bending)}$$

By a total eccentricity of calculation :  $e = e_1 + e_2$

With :

$e_1$  : eccentricity (called first-order), of the resultant of normal stresses, before the application of additional eccentricities,

$e_2$  : addition eccentricity translating initial geometric imperfections ( after execution ).

$e_a$  : eccentricity due to second arder effects.

$$\begin{cases} e_1 = \frac{M_u}{N_u} + e_a \\ e_2 = \frac{3 \times L_f^2}{10^4 \times h} (2 + \alpha \emptyset) \end{cases}$$

With :

L : total height of the column.

$L_f$  : buckling length of the column.

h : total length of the column section in the direction of buckling.

$\alpha$  : the ratio of the moment of the first order, due to the permanent and quasi-permanent loads, at the total moment of the first order, these moments being taken before the

application of the coefficients :  $\alpha = 10 \left( 1 - \frac{M_u}{1.5 M_{ser}} \right)$

$\emptyset$  : is the ratio of the final deformation due to creep to the instantaneous deformation under the load considered, this ratio is generally taken to be equal to 2.

$$L_f = 0.7 \times L$$

$$e_a = \text{Max} \left\{ 2\text{cm} ; \frac{L}{250} \right\}$$

- Filling coefficient :

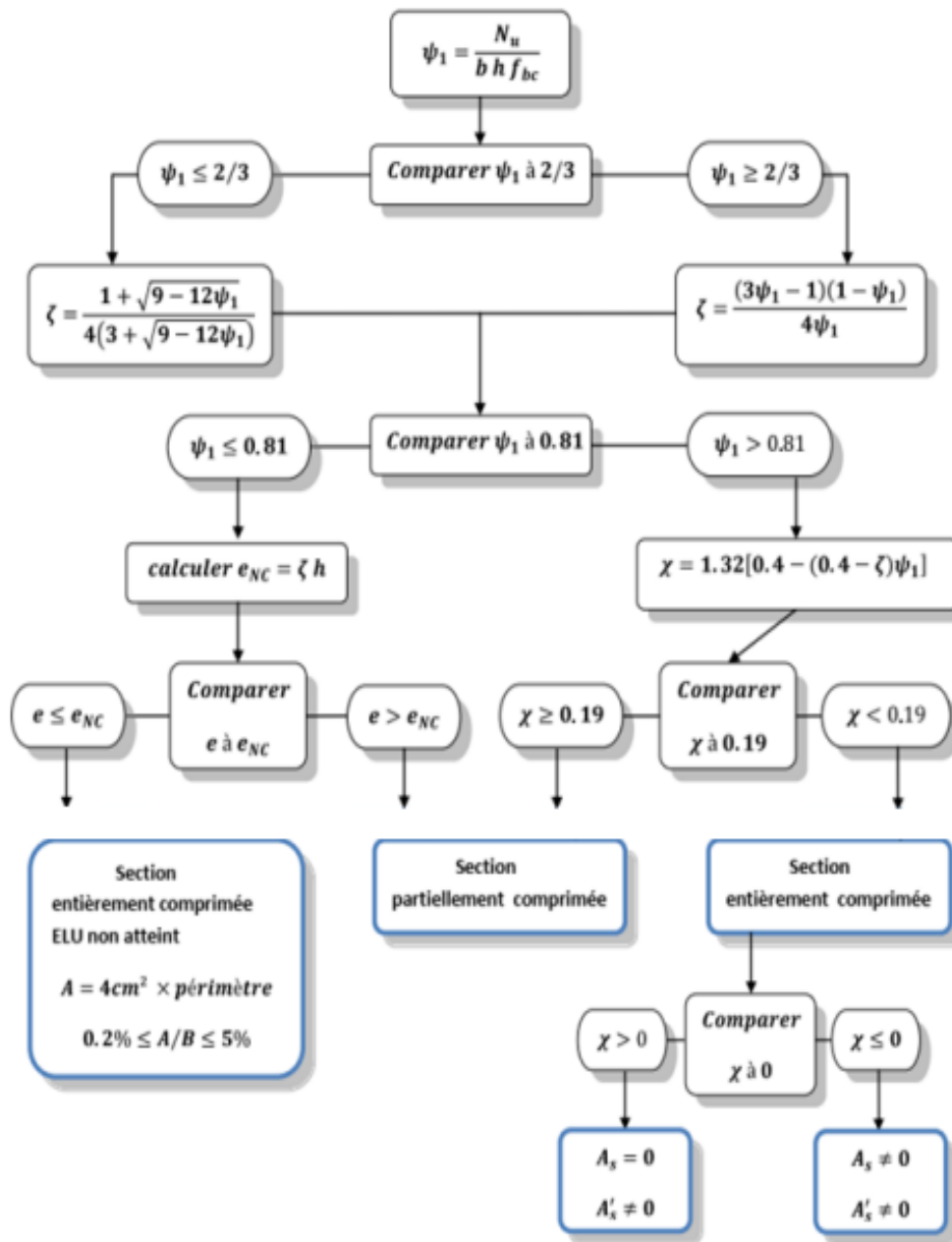

Figure V.14: Flowchart justifying the State of stress of the sections subjected to

To determine the reinforcement in each case of section above, follow the following flowchart :

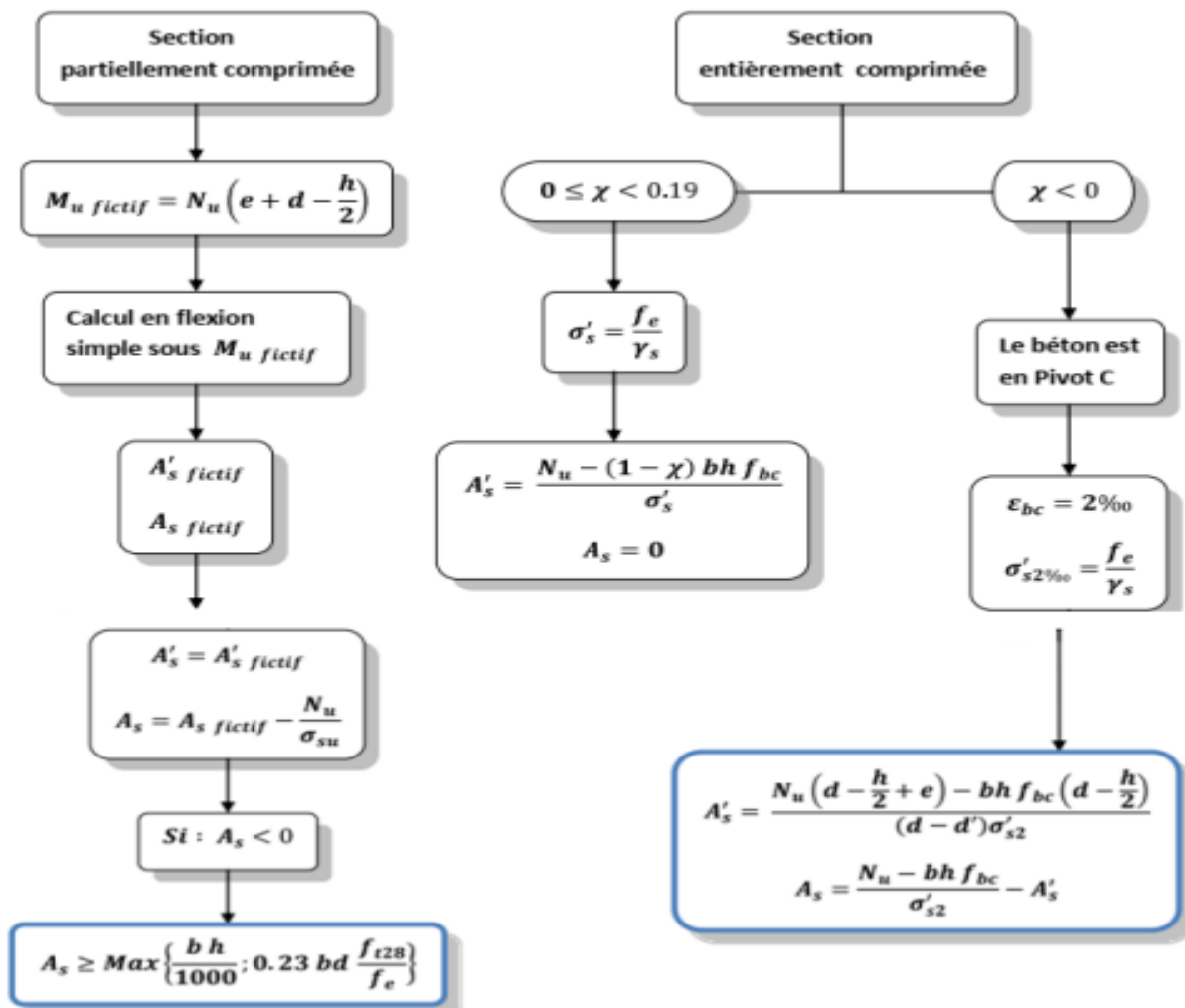
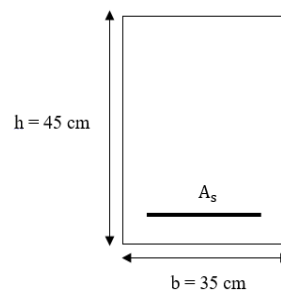

Figure V.15 : folwchart for calculating reinforcement section according to the state of stress

**V.6.5. reinforcement of columns :**

Calculation example : (column 35cm × 45cm)

$d = 0.9 \times h = 0.9 \times 0.45 = 0.402 \text{ m}$



Tab V.6 : sollicitation of the column (35cm \* 45cm)

Figure V.16 : Calculation cross section for columns

Situation	Case
-----------	------

<b>ULS</b>	$N_{\max} = 110.66 \text{ T} \rightarrow M_{\text{corres}}^{\max} = 0.41 \text{ T.m} \rightarrow M_{\text{ser}} = 0.30 \text{ T.m}$ $N_{\min} = 1.79 \text{ T} \rightarrow M_{\text{corres}}^{\max} = 2.15 \text{ T.m} \rightarrow M_{\text{ser}} = 1.57 \text{ T.m}$ $M_{\max} = 4.73 \text{ T} \rightarrow N_{\text{corres}} = 10.56 \text{ T.m} \rightarrow M_{\text{ser}} = 3.43 \text{ T.m}$
<b>ALS</b>	$N_{\max} = 111.77 \text{ T} \rightarrow M_{\text{corres}}^{\max} = 2.95 \text{ T.m} \rightarrow M_{\text{ser}} = 0.46 \text{ T.m}$ $N_{\min} = 2.95 \text{ T} \rightarrow M_{\text{corres}}^{\max} = 3.14 \text{ T.m} \rightarrow M_{\text{ser}} = 1.34 \text{ T.m}$ $M_{\max} = 2.95 \text{ T} \rightarrow N_{\text{corres}} = 3.14 \text{ T.m} \rightarrow M_{\text{ser}} = 3.17 \text{ T.m}$

**ULS:**

Case n° 01 :  $N_{\max} = 110.66 \text{ T} \rightarrow M_{\text{corres}}^{\max} = 0.41 \text{ T.m}$

a) Calculation of the eccentricity:

$$e_a = \max \left\{ 2\text{cm} ; \frac{L}{250} \right\} = \max \left\{ 2\text{cm} ; \frac{306}{250} \right\} = \max \{ 2\text{cm} ; 1.224\text{cm} \} = 2\text{cm}$$

$$e_a = 0.02\text{m}$$

$$e_1 = \frac{M_u}{N_u} = \frac{0.41 \times 10^{-2}}{110.69 \times 10^{-2}} = 3.70 \times 10^{-3}\text{m}$$

$$\alpha = 10 \times \left( 1 - \frac{M_u}{1.5 \times M_{\text{ser}}} \right) = 10 \times \left( 1 - \frac{0.41 \times 10^{-2}}{1.5 \times 0.30 \times 10^{-2}} \right) = 0.888$$

$$\emptyset = 2 \quad ; \quad L = 3.06 \text{ m} \quad ; \quad L_f = 0.7 \times L = 0.7 \times 3.06 = 2.14 \text{ m}$$

$$e_2 = \frac{3 \times L_f^2}{10^4 \times h} (2 + \alpha \emptyset) = \frac{3 \times 2.14^2}{10000 \times 0.45} \times (2 + (0.888 \times 2)) = 0.0115\text{m}$$

$$e_{\text{tot}} = 0.02 + 3.70 \times 10^{-3} + 0.0115 = 0.0352$$

b) Filling coefficient :

$$\psi = \frac{N_u}{b \times h \times f_{bc}} = \frac{110.66 \times 10^{-2}}{0.35 \times 0.45 \times 14.2} = 0.494$$

$$\psi = 0.494 < 0.81 \dots \dots \dots \text{cv}$$

$$\psi = 0.494 < \frac{2}{3} = 0.667 \dots \dots \dots \text{cv}$$

So; we determine the relative critical eccentricity :  $\xi = \frac{1 + \sqrt{9 - 12 \times \psi}}{4 \times (3 + \sqrt{9 - 12 \times \psi})} =$   
 $\frac{1 + \sqrt{9 - 12 \times 0.494}}{4 \times (3 + \sqrt{9 - 12 \times 0.494})} = 0.144$

We calculate :  $e_{Nc} = h \times \xi = 0.45 \times 0.144 = 0.0648 \text{ m}$

So,  $e = 0.0352 \text{ m} < e_{Nc} = 0.0648 \text{ m}$

So; the section is fully compressed and the ultimate limit state is not reached; we place a minimum percentage of reinforcement identical to that of the column :

$A = (4 \text{ cm}^2 \times \text{the perimeter of the section, the rate of reinforcement in the concrete section ; } 0.2\% \leq \frac{A}{B} \leq 5\%)$

$A = (4 \times (0.35 + 0.45) \times 2) = 6.4 \text{ cm}^2$

$0.2\% \leq \frac{6.4}{35 \times 45} \leq 5\% \quad \Rightarrow \quad 0.2\% \leq 0.0040 \leq 5\% \dots \dots \dots cv$

So :  $A_s = 6.4 \text{ cm}^2$

➤ Case n° 02 :  $N_{min} = 1.79 \text{ T} \quad \rightarrow \quad M_{corres}^{max} = 2.15 \text{ T.m}$

a) Calculation of the eccentricity:

$e_a = \max \left\{ 2\text{cm} ; \frac{L}{250} \right\} = \max \left\{ 2\text{cm} ; \frac{306}{250} \right\} = \max \{ 2\text{cm} ; 1.224\text{cm} \} = 2\text{cm}$

$e_a = 0.02\text{m}$

$e_1 = \frac{M_u}{N_u} = \frac{2.15 \times 10^{-2}}{1.79 \times 10^{-2}} = 1.201\text{m}$

$\alpha = 10 \times \left( 1 - \frac{M_u}{1.5 \times M_{ser}} \right) = 10 \times \left( 1 - \frac{2.15 \times 10^{-2}}{1.5 \times 1.57 \times 10^{-2}} \right) = 0.870$

$\emptyset = 2 \quad ; \quad L = 3.06 \text{ m} \quad ; \quad L_f = 0.7 \times L = 0.7 \times 3.06 = 2.14 \text{ m}$

$e_2 = \frac{3 \times L_f^2}{10^4 \times h} (2 + \alpha \emptyset) = \frac{3 \times 2.14^2}{10000 \times 0.45} \times (2 + (0.870 \times 2)) = 0.011\text{m}$

$e_{tot} = 0.02 + 1.201 + 0.011 = 1.232$

b) Filling coefficient :

$$\psi = \frac{N_u}{b \times h \times f_{bc}} = \frac{1.79 \times 10^{-2}}{0.35 \times 0.45 \times 14.2} = 0.008$$

$$\psi = 0.008 < 0.81 \dots \dots \dots cv$$

$$\psi = 0.008 < \frac{2}{3} = 0.667 \dots \dots \dots cv$$

So; we determine the relative critical eccentricity :  $\xi = \frac{1 + \sqrt{9 - 12 \times \psi}}{4 \times (3 + \sqrt{9 - 12 \times \psi})} =$

$$\frac{1 + \sqrt{9 - 12 \times 0.008}}{4 \times (3 + \sqrt{9 - 12 \times 0.008})} = 0.166$$

We calculate :  $e_{Nc} = h \times \xi = 0.45 \times 0.166 = 0.0747 \text{ m}$

So,  $e = 1.232 \text{ m} > e_{Nc} = 0.0747 \text{ m}$

So; the section is partially compressed and the ultimate limit state may not be reached.

Calculating the fictitious moment :

$$M_{u \text{ ficti}} = M_u + N_u \left( d - \frac{h}{2} \right) = N_u \times \left( e + d - \frac{h}{2} \right)$$

$$M_{u \text{ ficti}} = 1.79 \times 10^{-2} \times \left( 1.232 + 0.405 - \frac{0.45}{2} \right) = 0.025 \text{ MN.m}$$

$$\mu = \frac{M_{u \text{ ficti}}}{b \times d^2 \times f_{bc}} = \frac{0.025}{0.35 \times 0.405^2 \times 14.2} = 0.030 < \mu_{\text{limit}} = 0.391 \rightarrow A'_s = 0$$

$$\mu = 0.030 < 0.186 \rightarrow \text{pivot } A$$

$$\alpha_u = 1.25 \left( 1 - \sqrt{1 - 2 \times \mu} \right) = 1.25 \times \left( 1 - \sqrt{1 - 2 \times 0.030} \right) = 0.038$$

$$A_{s \text{ ficti}} = \frac{0.8 \times \alpha_u \times b \times d \times f_{bc}}{\sigma_s} = \frac{0.8 \times 0.038 \times 0.35 \times 0.405 \times 14.2}{348}$$

$$A_{s \text{ ficti}} = 1.758 \times 10^{-4} \text{ m}^2 = 1.758 \text{ cm}^2$$

$$A_s = A_{s \text{ ficti}} - \frac{N_u}{\sigma_s} = 1.758 - \frac{1.79 \times 10^{-2}}{348} = 1.758 \text{ cm}^2$$

Case n° 03:  $M_{\text{max}} = 4.73 \text{ T} \rightarrow N_{\text{corres}} = 10.56 \text{ T.m}$

a) Calculation of the eccentricity:

$$e_a = \max \left\{ 2\text{cm} ; \frac{L}{250} \right\} = \max \left\{ 2\text{cm} ; \frac{306}{250} \right\} = \max \{ 2\text{cm} ; 1.224\text{cm} \} = 2\text{cm}$$

$$e_a = 0.02\text{m}$$

$$e_1 = \frac{M_u}{N_u} = \frac{4.73 \times 10^{-2}}{10.56 \times 10^{-2}} = 0.447\text{m}$$

$$\alpha = 10 \times \left( 1 - \frac{M_u}{1.5 \times M_{\text{ser}}} \right) = 10 \times \left( 1 - \frac{4.73 \times 10^{-2}}{1.5 \times 3.43 \times 10^{-2}} \right) = 0.806$$

$$\emptyset = 2 \quad ; \quad L = 3.06 \text{ m} \quad ; \quad L_f = 0.7 \times L = 0.7 \times 3.06 = 2.14 \text{ m}$$

$$e_2 = \frac{3 \times L_f^2}{10^4 \times h} (2 + \alpha \emptyset) = \frac{3 \times 2.14^2}{10000 \times 0.45} \times (2 + (0.806 \times 2)) = 0.011\text{m}$$

$$e_{\text{tot}} = 0.02 + 0.447 + 0.011 = 0.478$$

b) Filling coefficient :

$$\psi = \frac{N_u}{b \times h \times f_{bc}} = \frac{10.56 \times 10^{-2}}{0.35 \times 0.45 \times 14.2} = 0.047$$

$$\psi = 0.047 < 0.81 \dots \dots \dots \text{cv}$$

$$\psi = 0.047 < \frac{2}{3} = 0.667 \dots \dots \dots \text{cv}$$

$$\text{So; we determine the relative critical eccentricity : } \xi = \frac{1 + \sqrt{9 - 12 \times \psi}}{4 \times (3 + \sqrt{9 - 12 \times \psi})} = \frac{1 + \sqrt{9 - 12 \times 0.047}}{4 \times (3 + \sqrt{9 - 12 \times 0.047})} =$$

$$0.165$$

$$\text{We calculate : } e_{Nc} = h \times \xi = 0.45 \times 0.165 = 0.0743 \text{ m}$$

$$\text{So, } e = 0.478 \text{ m} > e_{Nc} = 0.0743\text{m}$$

So; the section is partially compressed and the ultimate limit state may not be reached.

Calculating the fictitious moment :

$$M_{u \text{ ficti}} = M_u + N_u \left( d - \frac{h}{2} \right) = N_u \times \left( e + d - \frac{h}{2} \right)$$

$$M_{u \text{ ficti}} = 10.56 \times 10^{-2} \times \left( 0.478 + 0.405 - \frac{0.45}{2} \right) = 0.0694 \text{ MN.m}$$

$$\mu = \frac{M_{u \text{ ficti}}}{b \times d^2 \times f_{bc}} = \frac{0.0694}{0.35 \times 0.405^2 \times 14.2} = 0.085 < \mu_{\text{limit}} = 0.391 \rightarrow A'_s = 0$$

$$\mu = 0.085 < 0.186 \rightarrow \text{pivot } A$$

$$\alpha_u = 1.25 (1 - \sqrt{1 - 2 \times \mu}) = 1.25 \times (1 - \sqrt{1 - 2 \times 0.085}) = 0.111$$

$$A_{s \text{ ficti}} = \frac{0.8 \times \alpha_u \times b \times d \times f_{bc}}{\sigma_s} = \frac{0.8 \times 0.111 \times 0.35 \times 0.405 \times 14.2}{348}$$

$$A_{s \text{ ficti}} = 5.136 \times 10^{-4} \text{m}^2 = 5.136 \text{ cm}^2$$

$$A_s = A_{s \text{ ficti}} - \frac{N_u}{\sigma_s} = 5.136 - \frac{10.56 \times 10^{-2}}{348} = 5.135 \text{ cm}^2$$

**ALS :**

$$\text{Case n}^\circ 01 : N_{\text{max}} = 111.77 \text{ T} \rightarrow M_{\text{corres}}^{\text{max}} = 2.95 \text{ T.m}$$

a) Calculation of the eccentricity:

$$e_a = \max \left\{ 2\text{cm} ; \frac{L}{250} \right\} = \max \left\{ 2\text{cm} ; \frac{306}{250} \right\} = \max \{ 2\text{cm} ; 1.224\text{cm} \} = 2\text{cm}$$

$$e_a = 0.02\text{m}$$

$$e_1 = \frac{M_u}{N_u} = \frac{2.95 \times 10^{-2}}{111.77 \times 10^{-2}} = 0.0263 \text{ m}$$

$$\alpha = 1\emptyset = 2 \quad ; \quad L = 3.06 \text{ m} \quad ; \quad L_f = 0.7 \times L = 0.7 \times 3.06 = 2.14 \text{ m}$$

$$e_2 = \frac{3 \times L_f^2}{10^4 \times h} (2 + \alpha \emptyset) = \frac{3 \times 2.14^2}{10000 \times 0.45} \times (2 + (1 \times 2)) = 0.0122 \text{ m}$$

$$e_{\text{tot}} = 0.02 + 0.0263 + 0.0122 = 0.0585$$

b) Filling coefficient :

$$\psi = \frac{N_u}{b \times h \times f_{bc}} = \frac{111.77 \times 10^{-2}}{0.35 \times 0.45 \times 18.48} = 0.384$$

$$\psi = 0.384 < 0.81 \dots \dots \dots \text{cv}$$

$$\psi = 0.384 < \frac{2}{3} = 0.667 \dots \dots \dots \text{cv}$$

$$\text{So; we determine the relative critical eccentricity : } \xi = \frac{1 + \sqrt{9 - 12 \times \psi}}{4 \times (3 + \sqrt{9 - 12 \times \psi})} = \frac{1 + \sqrt{9 - 12 \times 0.384}}{4 \times (3 + \sqrt{9 - 12 \times 0.384})} =$$

$$0.151$$

We calculate :  $e_{Nc} = h \times \xi = 0.45 \times 0.151 = 0.0683 \text{ m}$

So,  $e = 0.0585 \text{ m} < e_{Nc} = 0.0683 \text{ m}$

So; the section is fully compressed and the ultimate limit state is not reached; we place a minimum percentage of reinforcement identical to that of the column :

$A = (4 \text{ cm}^2 \times \text{the perimeter of the section, the rate of reinforcement in the concrete section ; } 0.2\% \leq \frac{A}{B} \leq 5\%)$

$$A = (4 \times (0.35 + 0.45) \times 2) = 6.4 \text{ cm}^2$$

$$0.2\% \leq \frac{6.4}{35 \times 45} \leq 5\% \quad \Rightarrow \quad 0.2\% \leq 0.0040 \leq 5\% \dots \dots \dots \text{cv}$$

$$\text{So : } A_s = 6.4 \text{ cm}^2$$

$$\text{Case n}^\circ 02 : N_{\min} = 2.95 \text{ T} \quad \rightarrow \quad M_{\text{corres}}^{\max} = 3.14 \text{ T.m} \quad N_u = 1.83 \text{ T.m}$$

a) Calculation of the eccentricity :

$$e_a = \max \left\{ 2\text{cm} ; \frac{L}{250} \right\} = \max \left\{ 2\text{cm} ; \frac{306}{250} \right\} = \max \{ 2\text{cm} ; 1.224\text{cm} \} = 2\text{cm}$$

$$e_a = 0.02\text{m}$$

$$e_1 = \frac{M_u}{N_u} = \frac{3.14 \times 10^{-2}}{2.95 \times 10^{-2}} = 1.064 \text{ m}$$

$$\alpha = 10 \times \left( 1 - \frac{M_u}{1.5 \times M_{ser}} \right) = 10 \times \left( 1 - \frac{1.83 \times 10^{-2}}{1.5 \times 1.34 \times 10^{-2}} \right) = 0.962$$

$$\emptyset = 2 \quad ; \quad L = 3.06 \text{ m} \quad ; \quad L_f = 0.7 \times L = 0.7 \times 3.06 = 2.14 \text{ m}$$

$$e_2 = \frac{3 \times L_f^2}{10^4 \times h} (2 + \alpha \emptyset) = \frac{3 \times 2.14^2}{10000 \times 0.45} \times (2 + (0.962 \times 2)) = 7.986 \times 10^{-3} \text{ m}$$

$$e_{tot} = 0.02 + 1.064 + 7.982 \times 10^{-3} = 1.092$$

b) Filling coefficient :

$$\psi = \frac{N_u}{b \times h \times f_{bc}} = \frac{2.95 \times 10^{-2}}{0.35 \times 0.45 \times 18.48} = 0.0101$$

$$\psi = 0.0101 < 0.81 \dots \dots \dots \text{cv}$$

$$\psi = 0.0101 < \frac{2}{3} = 0.667 \dots \text{cv}$$

So; we determine the relative critical eccentricity :  $\xi = \frac{1 + \sqrt{9 - 12 \times \psi}}{4 \times (3 + \sqrt{9 - 12 \times \psi})} =$

$$\frac{1 + \sqrt{9 - 12 \times 0.0101}}{4 \times (3 + \sqrt{9 - 12 \times 0.0101})} = 0.1663$$

We calculate :  $e_{Nc} = h \times \xi = 0.45 \times 0.1663 = 0.0748 \text{ m}$

So,  $e = 1.092 \text{ m} > e_{Nc} = 0.0748 \text{ m}$

So; the section is partially compressed and the ultimate limit state may not be reached.

c) Calculating the fictitious moment :

$$M_{u \text{ ficti}} = M_u + N_u \left( d - \frac{h}{2} \right) = N_u \times \left( e + d - \frac{h}{2} \right)$$

$$M_{u \text{ ficti}} = 2.95 \times 10^{-2} \times \left( 1.092 + 0.405 - \frac{0.45}{2} \right) = 0.0375 \text{ MN.m}$$

$$\mu = \frac{M_{u \text{ ficti}}}{b \times d^2 \times f_{bc}} = \frac{0.0375}{0.35 \times 0.405^2 \times 18.48} = 0.0353 < \mu_{\text{limit}} = 0.391 \rightarrow A'_s = 0$$

$$\mu = 0.0353 < 0.186 \rightarrow \text{pivot } A$$

$$\alpha_u = 1.25 \left( 1 - \sqrt{1 - 2 \times \mu} \right) = 1.25 \times \left( 1 - \sqrt{1 - 2 \times 0.0353} \right) = 0.0449$$

$$A_{s \text{ ficti}} = \frac{0.8 \times \alpha_u \times b \times d \times f_{bc}}{\sigma_s} = \frac{0.8 \times 0.0449 \times 0.35 \times 0.405 \times 18.48}{400}$$

$$A_{s \text{ ficti}} = 2.352 \times 10^{-4} \text{ m}^2 = 2.352 \text{ cm}^2$$

$$A_s = A_{s \text{ ficti}} - \frac{N_u}{\sigma_s} = 2.352 - \frac{2.95 \times 10^{-2}}{400} = 2.352 \text{ cm}^2$$

➤ Case n° 03 :  $M_{\text{max}} = 7.34 \text{ T} \rightarrow N_{\text{corres}} = 4.42 \text{ T.m}$

a) Calculation of the eccentricity :

$$e_a = \max \left\{ 2 \text{ cm} ; \frac{L}{250} \right\} = \max \left\{ 2 \text{ cm} ; \frac{306}{250} \right\} = \max \{ 2 \text{ cm} ; 1.224 \text{ cm} \} = 2 \text{ cm}$$

$$e_a = 0.02 \text{ m}$$

$$e_1 = \frac{M_u}{N_u} = \frac{7.34 \times 10^{-2}}{4.42 \times 10^{-2}} = 1.660 \text{ m}$$

$$\alpha = 1\emptyset = 2 \quad ; \quad L = 3.06 \text{ m} \quad ; \quad L_f = 0.7 \times L = 0.7 \times 3.06 = 2.14 \text{ m}$$

$$e_2 = \frac{3 \times L_f^2}{10^4 \times h} (2 + \alpha \emptyset) = \frac{3 \times 2.14^2}{10000 \times 0.45} \times (2 + (1 \times 2)) = 0.0122 \text{ m}$$

$$e_{tot} = 0.02 + 1.660 + 0.0122 = 1.692$$

b) Filling coefficient :

$$\psi = \frac{N_u}{b \times h \times f_{bc}} = \frac{4.42 \times 10^{-2}}{0.35 \times 0.45 \times 18.48} = 0.015$$

$$\psi = 0.015 < 0.81 \dots \dots \dots cv$$

$$\psi = 0.015 < \frac{2}{3} = 0.667 \dots \dots \dots cv$$

So; we determine the relative critical eccentricity :  $\xi = \frac{1 + \sqrt{9 - 12 \times \psi}}{4 \times (3 + \sqrt{9 - 12 \times \psi})} =$   
 $\frac{1 + \sqrt{9 - 12 \times 0.015}}{4 \times (3 + \sqrt{9 - 12 \times 0.015})} = 0.166$

We calculate :  $e_{Nc} = h \times \xi = 0.45 \times 0.166 = 0.0747 \text{ m}$

So,  $e = 1.692 \text{ m} > e_{Nc} = 0.0747 \text{ m}$

So; the section is partially compressed and the ultimate limit state may not be reached.

c) Calculating the fictitious moment :

$$M_{u \text{ ficti}} = M_u + N_u \left( d - \frac{h}{2} \right) = N_u \times \left( e + d - \frac{h}{2} \right)$$

$$M_{u \text{ ficti}} = 4.42 \times 10^{-2} \times \left( 1.692 + 0.405 - \frac{0.45}{2} \right) = 0.083 \text{ MN.m}$$

$$\mu = \frac{M_{u \text{ ficti}}}{b \times d^2 \times f_{bc}} = \frac{0.083}{0.35 \times 0.405^2 \times 18.48} = 0.078 < \mu_{\text{limit}} = 0.391 \rightarrow A'_s = 0$$

$$\mu = 0.078 < 0.186 \rightarrow \text{pivot } A$$

$$\alpha_u = 1.25 (1 - \sqrt{1 - 2 \times \mu}) = 1.25 \times (1 - \sqrt{1 - 2 \times 0.078}) = 0.102$$

$$A_{s \text{ ficti}} = \frac{0.8 \times \alpha_u \times b \times d \times f_{bc}}{\sigma_s} = \frac{0.8 \times 0.102 \times 0.35 \times 0.405 \times 18.48}{400}$$

$$A_{s \text{ ficti}} = 5.34 \times 10^{-4} \text{m}^2 = 5.34 \text{ cm}^2$$

$$A_s = A_{s \text{ ficti}} - \frac{N_u}{\sigma_s} = 5.34 - \frac{4.42 \times 10^{-2}}{400} = 5.34 \text{ cm}^2$$

Tab V.7 Reinforcement of the columns.

Case	Situation	N (T)	M (T.m)	Nature of the section	A <sub>s</sub> (cm <sup>2</sup> )
N <sub>max</sub> → M <sub>corre</sub>	Durable	110.66	0.41	fully compressed	6.4
N <sub>min</sub> → M <sub>corre</sub>		1.79	2.15	partially compressed	1.758
M <sub>max</sub> → N <sub>corre</sub>		4.73	10.56	partially compressed	5.135
N <sub>max</sub> → M <sub>corre</sub>	Accidental	111.77	2.95	fully compressed	6.4
N <sub>min</sub> → M <sub>corre</sub>		2.95	3.14	partially compressed	2.352
M <sub>max</sub> → N <sub>corre</sub>		7.34	4.42	partially compressed	5.34

$$A_s = 6.4 \text{ cm}^2$$

### V.6.6. Verification required :

- Non-frailty condition : (CBA93 Art A.4.2)

It is necessary to check that:  $A_s \geq A_{s \text{ min}}$

$$A_{s \text{ min}} = \frac{0.23 \cdot b \cdot d \cdot f_{t28}}{f_e} = \frac{0.23 \times 0.35 \times 0.405 \times 2.1}{400} = 1.71 \times 10^{-4} \text{m}^2$$

$$A_{s \min} = 1.71 \text{ cm}^2$$

$$A_s = 6.4 \text{ cm}^2 > A_{s \min} = 1.71 \text{ cm}^2 \dots\dots\dots \text{CV}$$

Therefore:

$$\text{We take : } 4\text{HA16}+8\text{HA14} = 20.36 \text{ cm}^2$$

- Verification of longitudinal reinforcement according to the (RPA 99/V2003 Art 7.5.2.1) :

Longitudinal reinforcement must be high-adhesion, straight and without hooks.

- **their minimum percentage will be 0.8% in zone IIa :**

$$A_{\min \text{RPA}} = 0.8\% b h = 0.008 \times 35 \times 0.45 = 1.26 \times 10^{-3} = 12.6 \text{ cm}^2$$

$$A_s = 4\text{HA16} + 8\text{HA14} = 20.36 \text{ cm}^2$$

$$A_s = 20.36 \text{ cm}^2 > A_{\min} = 12.6 \text{ cm}^2 \dots\dots\dots \text{CV}$$

- **The maximum total percentage of longitudinal steels is :**

Current area :

$$A_{s \max \text{RPA}} = 3\% b h = 0.03 \times 35 \times 45 = 47.25 \text{ cm}^2$$

$$A_s = 4\text{HA16} + 8\text{HA14} = 20.36 \text{ cm}^2$$

$$A_s = 20.36 \text{ cm}^2 < A_{\max} = 47.25 \text{ cm}^2 \dots\dots\dots \text{CV}$$

Overlay area :

$$A_{s \max \text{RPA}} = 6\% b h = 0.06 \times 35 \times 45 = 94.5 \text{ cm}^2$$

$$A_s = 4\text{HA16} + 8\text{HA14} = 20.36 \text{ cm}^2$$

$$A_s = 20.36 \text{ cm}^2 < A_{\max} = 94.5 \text{ cm}^2 \dots\dots\dots \text{CV}$$

- Minimum diameter:  $\emptyset_{1 \min} \geq 12 \text{ mm}$

$$\emptyset_{1 \min} = 14 \text{ mm} > 12 \text{ mm} \dots\dots\dots \text{CV}$$

- The minimum length of cover for Zone IIa is :

$$L_{\text{collection}} = 40\emptyset = 40 \times 1.4 = 56 \text{ cm} \quad \text{we take : } 60 \text{ cm}$$

### V.6.7. Transverse reinforcement :

$$\left\{ \begin{array}{l} \frac{A_t}{t} = \frac{\rho_a V_u}{h f_e} \\ \lambda_g = \left( \frac{l_f}{a} \text{ or } \frac{l_f}{b} \right) \\ t \leq \min(10\emptyset_1 ; 15\text{cm}) \quad \text{in nodal area} \\ t \leq 15\emptyset_1 \quad \text{in current area} \end{array} \right.$$

Column : (35 \* 45)

$$\lambda_g = \frac{l_f}{a} = \frac{214}{45} = 4.7 < 5 \quad \text{so } \rho_a = 3.75$$

**Nodal area spacing :**

$$t \leq \min\{10\emptyset_1 ; 15 \text{ cm}\} = \min\{10 \times 1.4 = 14 \text{ cm} ; 15 \text{ cm}\} = 14\text{cm}$$

$$t = 10 \text{ cm}$$

**Overlapping area spacing :**

$$t \leq 15\emptyset_1 = 15 \times 1.4 = 21 \text{ cm}$$

$$t = 15 \text{ cm}$$

**Transverse reinforcement in nodal area :**

$$A_t = \frac{\rho_a \times V_u \times t}{h_1 \times f_e} = \frac{3.75 \times 4.48 \times 10^{-2} \times 0.10}{0.45 \times 400} = (0.93 \times 10^{-5}) \times 10000 = 0.93 \text{ cm}^2$$

**Transverse reinforcement in current area :**

$$A_t = \frac{\rho_a \times V_u \times t}{h_1 \times f_e} = \frac{3.75 \times 4.48 \times 10^{-2} \times 0.15}{0.45 \times 400} = (1.4 \times 10^{-4}) \times 10000 = 1.40 \text{ cm}^2$$

**Minimum cross-section of the transverse reinforcement :**

$$\begin{cases} A_{\min} = 0,3\% * t * b & \text{if } \lambda_g \geq 5 \\ A_{\min} = 0,8\% * t * b & \text{if } \lambda_g \leq 3 \\ A_{\min} = \frac{(0,3\% * t * b) + (0,8\% * t * b)}{2} & \text{if } 3 < \lambda_g < 5 \end{cases}$$

**Nodal area :**

$$A_{\min} = \frac{(0,3\% * t * b) + (0,8\% * t * b)}{2}$$

$$A_{\min} = \frac{(0,003 * 0,1 * 0,35) + (0,008 * 0,1 * 0,35)}{2} = 1,925 * 10^{-4} \text{m}^2 = 1,925 \text{cm}^2$$

**Overlapping area :**

$$A_{\min} = \frac{(0,3\% * t * b) + (0,8\% * t * b)}{2}$$

$$A_{\min} = \frac{(0,003 * 0,15 * 0,35) + (0,008 * 0,15 * 0,35)}{2} = 2,88 * 10^{-4} \text{m}^2 = 2,88 \text{cm}^2$$

**Adopted cross-sections:**

$$A_s = 2,88 \text{cm} \quad \text{we take : } 4\text{HA}10 = 3,14 \text{cm}^2$$

**V.6.8. Shear force verification :**

It is necessary that:

$$\tau_u \leq \bar{\tau}_u$$

The ultimate shear stress is given by:

**Damaging cracking**

$$\bar{\tau}_u = \min \left\{ \frac{0,15 * f_{c28}}{\gamma_b} ; 5 \text{MPa} \right\} = \min \left\{ \frac{0,2 * 25}{1,5} = 2,5 \text{MPa} ; 5 \text{MPa} \right\} = 2,5 \text{MPa}$$

$$\tau_u = \frac{V}{b * d} = \frac{4,48 * 10^{-2}}{0,35 * 0,405} = 0,316 \text{MPa}$$

Therefore :

$$\tau_u = 0.316 \text{ MPa} \leq \bar{\tau}_u = 2.5 \text{ MPa} \dots\dots\dots\text{CV}$$

### V.6.9. Buckling Verification :

It must be verified that :  $\lambda < 50$

$$I = \frac{b \times h^3}{12} = \frac{0.35 \times 0.45^3}{12} = 2.657 \times 10^{-3} \text{ m}^4$$

$$i = \sqrt{\frac{I}{A}} = \sqrt{\frac{2.657 \times 10^{-3}}{0.35 \times 0.45}} = 0.126$$

$$\lambda = \frac{l_f}{i} = \frac{2.14}{0.129} = 16.5$$

$$\lambda = 16.5 < 50 \dots\dots\dots\text{CV}$$

V.6.10. Diagram of the reinforcement of column :

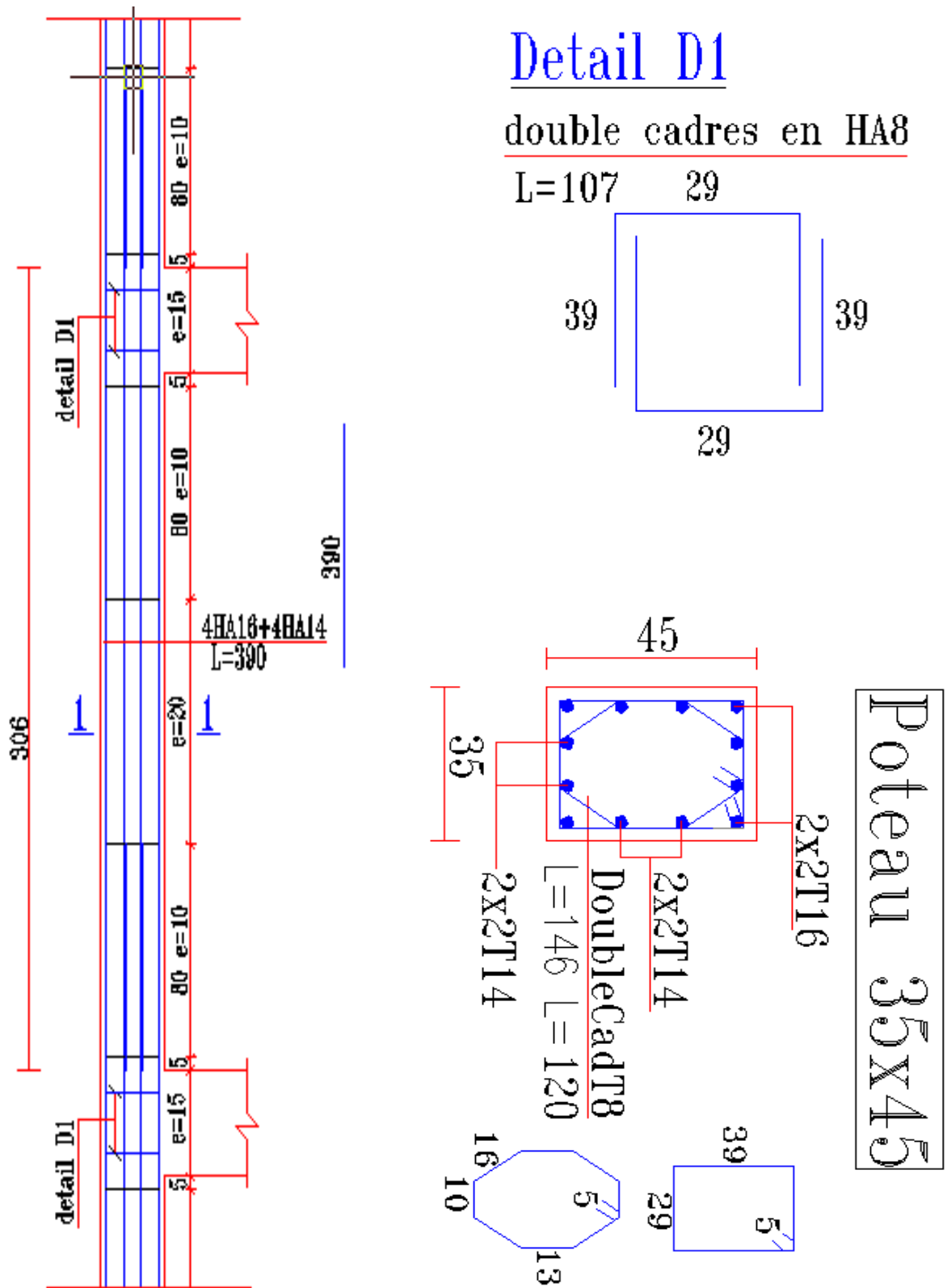

Figure V.17 :Diagram of the reinforcement of column

### □.7 Calculation of the sails :

The walls are bracing elements subject to vertical loads (dead loads and live loads) and to horizontal forces due to the earthquake.

Ils présentent deux plans l'un de faible inertie et l'autre de forte inertie ce qui impose une disposition dans les deux sens (x et y).

A sail works like a console recessed at its base, there are two types of sails which have a different behavior :

- Slender sails :  $\frac{h}{L} > 1.5$
- Short sails :  $\frac{h}{L} < 1.5$

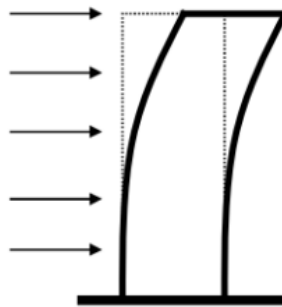

Figure V.18 : Behavior of the veil as a console

- Failure by bending.
- Rupture in bending by shear stress.
- Breaking by crushing or pulling concrete

In order to avoid the methods of termination mentioned above, the following procedures must be respected :

- For the first two modes of failure, the sections of the walls must have sufficient vertical and horizontal reinforcement.
- For the third mode, transverse reinforcement must be installed.

### V.7.1. Principles of sails sizing :

Under seismic action, more or less important parts of the end of the concrete wall, stressed in compression, that may be in the inelastic domain, This situation can be the cause of lateral stability.

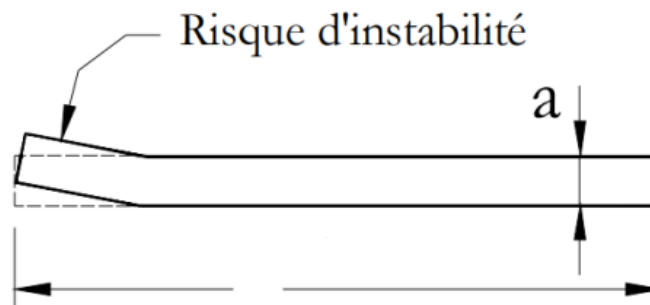

Figure V.19 : Lateral instability of the sails

As in view of this eventuality, seismic regulations impose a minimum thickness of the core at 15cm, and from a certain level of constraints, it is necessary to provide reinforcements at the ends of the walls designed like columns.

### V.7.2. Recommendation of RPA99/2003 :

❖ Specification for vertical steels (A.7.7.4.1 RPA99/2003) :

The vertical reinforcement shall be arranged in such a way that it will take up the compound bending stresses taking into account the requirements imposed by the RPA99 described below :

- The tensile force generated in a part of the wall must be taken up in full by the reinforcement, the minimum percentage of which is 0.20% of the horizontal section of the tensile concrete.
- Vertical bars in extreme areas should be tied with horizontal frames whose spacing should not be greater than the thickness of the wall.
- At each end of the wall, the spacing of the bars must be reduced by half over (1/10) of the width of the wall, this spacing must be at most equal to 15cm.

- If there is a lot of compressive force on the extremity, the vertical members must comply with the conditions imposed on the poles.
- The vertical bars on the top level must have hooks at the top. All other bars have no hooks (overlapping joint).

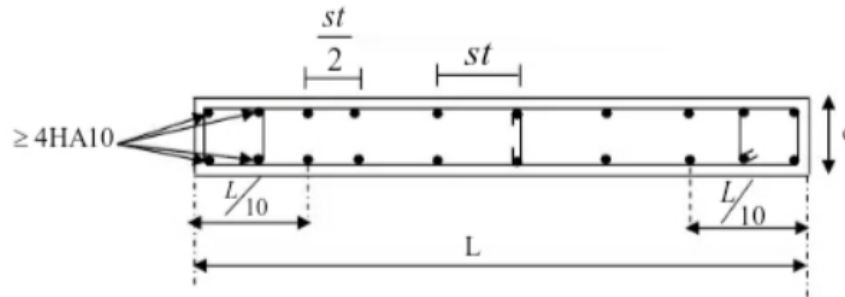

Figure V.20 : Arrangement of vertical reinforcement in the walls

❖ Specification for Horizontal Steels (A.7.7.4.2 RPA99/2003) :

Horizontal bars must be provided with  $135^\circ$  hooks with a length of  $10\emptyset$ .

In the case where there are stiffness heels, the horizontal bars must be anchored without hooks if the dimensions of the heels allow for a straight anchorage.

- The section of reinforcement corresponding to the percentage  $\rho_v$  must be distributed in half on each of the faces of the strip of the wall in question.
- The section of the horizontal reinforcement parallel to the faces of the wall must be distributed in half on each of the faces in a uniform manner over the entire length of the wall or of the limited wall element through openings.

❖ Transverse reinforcement :

The transverse reinforcement is perpendicular to the faces of the slats.

They retain the two vertical reinforcement layers. These are generally pins whose role is to prevent buckling of vertical steels under the action of compression, according to the **article 7.7.4.3 of the RPA 2003**.

The two vertical reinforcement layers must be connected by at least (04) pins per square metre. In each tablecloth, the horizontal bars must be arranged outwards.

❖ Seam reinforcement :

Along the re-casting joints, the shear force must be taken by the seam steels, the cross-section of which must be calculated with the formula :

$$A_{vj} = 1.1 \frac{\bar{V}}{f_e}$$

This amount must be added to the section of tensioned steels needed to balance the tensile forces due to the overturning moments.

❖ Common rules (vertical and horizontal reinforcement) (A.7.7.4.3 RPA99/2003) :

**The minimum percentage of vertical and horizontal reinforcement is :**

- Overall in the veil section : 0, 15%.
- In the current area : 0.10%

**Overlap length :**

- $40\emptyset$  : for members located in areas where the reversal of the force sign is possible.
- $20\emptyset$  : for members located in compressed areas under the action of all possible combinations of loads.

### V.7.3. Reinforcement of the sails :

The stress method is used to determine the vertical reinforcement. She admits to making the stress calculations assuming a line diagram. The wall will be symmetrically welded, in order to ensure safety in the event of a reversal of the seismic action.

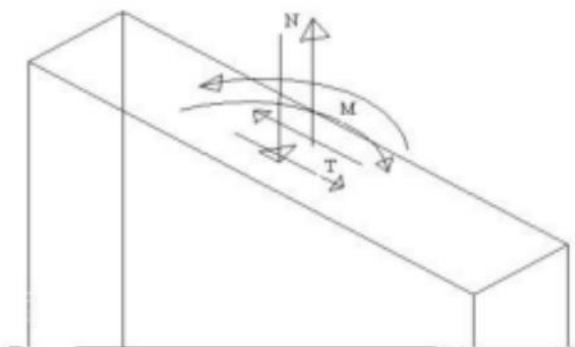

Figure V.21 : Stresses on the bracing sails

The reinforcement of the sails will be done for vertical strips of width  $d$  :

$$d \leq \min \left( \frac{h_e}{2} ; \frac{2}{3} L_c \right)$$

A veil is defined by these coordinates  $v$  and  $v'$  of the center of gravity  $G$ , its cross-section (area)  $(B)$ , its moment of inertia  $(I)$  with respect to its center of gravity  $G$ .

The method consists of determining the stress diagram (stress state of the plane section) from the worst-case loads using the following RDM formulas :

$$\begin{cases} \sigma_{\max} = \frac{N}{B} + \frac{M * v}{I} \\ \sigma_{\min} = \frac{N}{B} + \frac{M * v'}{I} \end{cases}$$

In our building. There are two types of sails, either :

- Type 1 (y-y direction) : Full sail.
- Type 2 (x-x direction) : Opening veil (trumeaux and lintels).

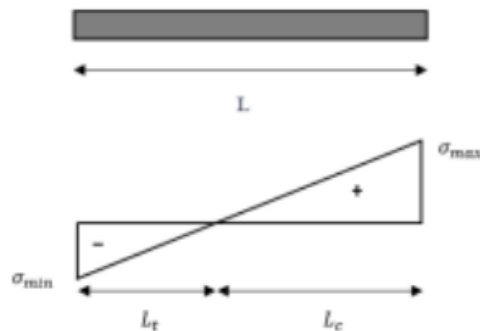

Figure V.22 : Constraints on the sails

#### V.7.4. Example of Calculation :

In this example, we will present the detailed calculation of the reinforcement of a single wall.

Table V.8 : Stresses of the sail.

Case	Combinaison	N (T)	M (T.m)	V <sub>max</sub> (T)
M <sub>max</sub> → N <sub>corr</sub>	G + Q + EX	65.12	377.62	84.85
N <sub>max</sub> → M <sub>corr</sub>	0.8G + EY	69.56	42.03	
N <sub>min</sub> → M <sub>corr</sub>	G + Q - EY	296.74	45.46	

Case n°1 : M<sub>max</sub> = 377.62 T.m

N<sub>corr</sub> = 65.12 T

Favorable case.

$$e = b = 0,20 \text{ m}$$

$$L = h = 5.50 \text{ m}$$

With :

► e : Thickness of the sail.

► L : Length of the sail.

$$\text{Minimum moment of inertia of the cross-section : } I = \frac{b \times h^3}{12} = \frac{0,20 \times 5.5^3}{12} = 2.77 \text{ m}^4$$

$$\text{Area of the concrete section : } B = b \times h = 0.20 \times 5.5 = 1.1 \text{ m}^2$$

$$y = \frac{L}{2} = \frac{5.5}{2} = 2.75 \text{ m}$$

$$\text{Flaming Length : } L_f = 0.8 \times h_e = 0.8 \times 3.06 = 2.45 \text{ m}$$

$$\text{Turning Radius : } i = \sqrt{\frac{B}{I}} = \sqrt{\frac{1.1}{2.77}} = 0.630 \text{ m}$$

$$\text{Slenderness : } \lambda = \frac{L_f \sqrt{12}}{b} = \frac{2.45 \sqrt{12}}{0.20} = 42.44 < 50$$

$$\text{So } \alpha = \frac{0.85}{1+0.20\left(\frac{\lambda}{35}\right)^2} = \frac{0.85}{1+0.20\left(\frac{42.44}{35}\right)^2} = 0.656$$

Reduced section :

$$Br = L \times (b - 2\text{cm}) = 5.5 \times (0.2 - 0.02) = 0.99\text{m}^2$$

$$\sigma_1 = \frac{N}{B} + \frac{M}{I}y = \frac{65.12 \times 10^{-2}}{1.1} + \frac{377.62 \times 10^{-2}}{2.77} \times 2.75 = 4.340 \text{ MPa}$$

$$\sigma_2 = \frac{N}{B} - \frac{M}{I}y = \frac{65.12 \times 10^{-2}}{1.1} - \frac{377.62 \times 10^{-2}}{2.77} \times 2.75 = -3.157 \text{ MPa}$$

$\sigma_1 \geq 0$  And  $\sigma_2 \leq 0$  So the section is partially compressed, Using the formula of

‘NAVIER-BERNOULLI’ The length of the taut area is evaluated from the triangles Similar.

Stretched length :

$$L_t = L \times \frac{|\sigma_2|}{|\sigma_1| + |\sigma_2|} = 5.5 \times \frac{3.157}{4.340 + 3.157} = 2.316 \text{ m}$$

Compressed Area Length :

$$L_c = L - L_t = 5.5 - 2.316 = 3.184 \text{ m}$$

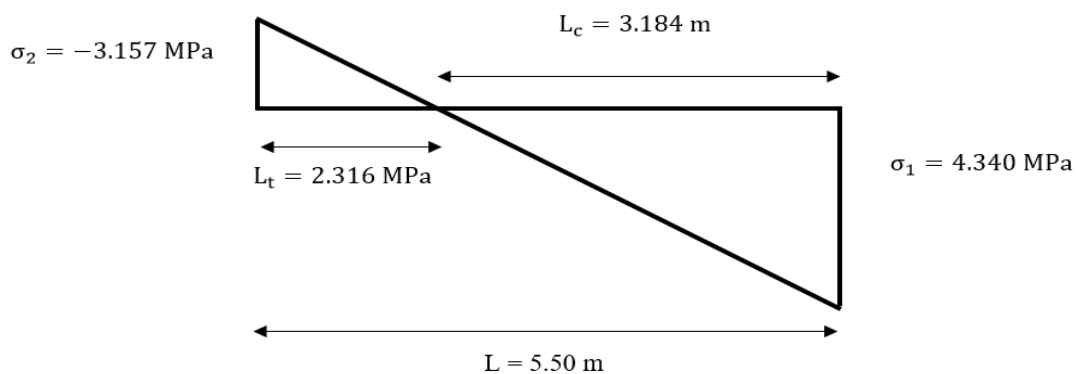

Figure V.23 : Constrain diagram

$$d \leq \min \left\{ \frac{h_e}{2}; \frac{2}{3} L_c \right\} = \min \left\{ \frac{3.06}{2}; \frac{2}{3} \times 3.184 \right\} = \min \{1.53; 2.123\} = 1.53 \text{ m}$$

Calculation of  $\sigma_2'$ :

$$\sigma_2' = \tan\alpha \times (L_t - d)$$

$$\tan\alpha = \frac{\sigma_2}{L_t} = \frac{-3.157}{2.316} = -1.363$$

$$\sigma_2' = -1.363 \times (2.316 - 1.53) = -1.07 \text{ MPa}$$

Therefore :

$$I' = \frac{e \times d^3}{12} = \frac{0.20 \times 1.53^3}{12} = 0.059 \text{ m}^4$$

$$y' = \frac{d}{2} = \frac{1.53}{2} = 0.77 \text{ m}$$

$$B' = e \times d = 0.2 \times 1.53 = 0.31 \text{ m}^2$$

$$N' = \frac{B'}{2} (\sigma_2 + \sigma_2') = \frac{0.31}{2} (-3.157 - 1.07) = -0.66 \text{ Kn}$$

$$M' = \frac{I'}{2y'} (\sigma_2 + \sigma_2') = \frac{0.059}{2 \times 0.77} (-3.157 - 1.07) = -0.162 \text{ Kn}$$

Eccentricity :

$$e_0 = \frac{M'}{N'} = \frac{-0.162}{-0.66} = 0.25$$

We put  $c = c' = 0.05 \text{ m}$

$$e_1 = \frac{d}{2} - e_0 - c' = \frac{1.53}{2} - 0.25 - 0.05 = 0.47$$

$$e_2 = \frac{d}{2} + e_0 - c' = \frac{1.53}{2} + 0.25 - 0.05 = 2.95$$

Then the determination of the reinforcement will be done as below :

$$A_s = \frac{N' \times e_2}{(e_1 + e_2) \times f_e} = \frac{0.66 \times 2.95}{(0.47 + 2.95) \times 400} = 1.423 \times 10^{-3} \text{ m}^2 = 14.23 \text{ cm}^2$$

$$A_s' = \frac{N' \times e_1}{(e_1 + e_2) \times f_e} = \frac{0.66 \times 0.47}{(0.47 + 2.95) \times 400} = 2.26 \times 10^{-4} \text{ m}^2 = 2.26 \text{ cm}^2$$

$$A_{s \text{ tot}} = A_s + A_s' = 14.23 + 2.26 = 16.49 \text{ cm}^2$$

For 1 ml :

Minimum reinforcement according to the RPP 99 V 2003 :

$$A_{s \min} = 0,20\% \times e \times L_t = 0.002 \times 20 \times 231.6 = 9.264 \text{ cm}^2$$

For 1 ml :

Globalement in the section of the sails : According to RPA 99 V 2003 (Art 7.7.4.3) :

$$A_{s \min} = 0,15\% \times e \times L = 0.0015 \times 20 \times 550 = 16.5 \text{ cm}^2$$

For 1 ml :

In the current zone: According to RPA 99 V 2003 (Art 7.7.4.3) :

$$A_{s \min} = 0,1\% \times e \times L = 0.0010 \times 20 \times 550 = 11 \text{ cm}^2$$

For 1 ml :

Choice of reinforcements:

- In the current area

$$A_s = \max(A_s ; A_{s \min}) = \max(2.99 ; 2.00) = 2.99 \text{ cm}^2/\text{ml}$$

$$\text{We take : } 4\text{HA}12 = 4.52 \text{ cm}^2$$

With a spacing determined by the following relation :  $S_t < \min(30; 15.e)$

$$S_t < \min(30; 15 \times 20) = \min(30; 300) = 30 \text{ cm}$$

$$\text{We take : } S_t = 20 \text{ cm}$$

- In a tense area (end area) :

$$A_s = \max(A_s ; A_{s \min}) = \max(2.99 ; 3.00) = 3.00 \text{ cm}^2/\text{ml}$$

$$\text{We take : } 5\text{HA}12 = 5.65 \text{ cm}^2$$

With a spacing determined by the following relation :  $S_t \leq \frac{S_t}{2}$

$$S_t \leq \frac{20}{2} = 10 \text{ cm}$$

$$S_t = 10 \text{ cm}$$

End Area Length according RPA 99 V 2003 :

$$L_{\text{end area}} = \frac{L}{10} = \frac{550}{10} = 55 \text{ cm}$$

Horizontal reinforcement (RPA Art 7.7.2) :  $\tau < \bar{\tau}_u$

$$\bar{\tau}_u = 0.2 \times f_{c28} = 0.2 \times 25 = 5 \text{ MPa}$$

$$\tau = \frac{1.4 \times T}{e \times L} = \frac{1.4 \times 84.85 \times 10^{-2}}{0.20 \times 5.5} = 1.079 \text{ MPa}$$

$$\tau = 1.079 \text{ MPa} < \bar{\tau}_u = 5 \text{ MPa} \dots\dots\dots \text{CV}$$

Calculation of the horizontal reinforcement resistant to shear force :

The cross-section of the core reinforcements is given by the following relation (CBA93 Art A.5.1.2.3)

$$\frac{A_t}{b_0 \times S_t} \geq \frac{\gamma \times (\tau - 0.3 \times f_{t28} \times K)}{0.9 \times f_e}$$

$K = 0 \Rightarrow$  in case of cracking considered very harmful, in the event of re-concreting not indented in the return surface.

$K = 1 \Rightarrow$  in flexion, without re-concreting.

$K = 1 + 3\sigma_{cm} / f_{c28} \Rightarrow$  in flexion compound with N compressive force.

$K = 1 + 10\sigma_{tm} / f_{c28} \Rightarrow$  in flexion compound with N tractive effort traction.

$\sigma_{cm}$  ;  $\sigma_{tm}$  : being the constraint Traction moyenne and Compression obtained by dividing the normal design force by the cross-section of the concrete.

The minimum percentage of horizontal reinforcement for a strip of 1 m in width.

o According (RPA 99/2003 Art 7.7.4.3)

- Globalement in the section of the sails 0.15%.
- In area current 0,10%.

Therefore :  $K = 0$

$$\frac{A_t}{b_0 \times S_t} \geq \frac{\tau}{0.9 \times f_e}$$

Spacing :  $S_t < \min (30; 15. e)$

$$S_t < \min(30; 15 \times 20) = \min(30; 300) = 30 \text{ cm}$$

We take :  $S_t = 20 \text{ cm}$

$$A_t = \frac{\tau \times b_0 \times S_t}{0.8 \times 400} = \frac{1.08 \times 20 \times 20}{0.8 \times 400} = 1.35 \text{ cm}^2$$

$$A_{t \min} = 0,1\% \times e \times L = 0.0010 \times 20 \times 550 = 11 \text{ cm}^2$$

$$\text{For 1 ml : } A_{t \min} = \frac{11}{5.5} = 2.00 \text{ cm}^2/\text{ml}$$

$$A_t = \max(A_t ; A_{t \min}) = \max(1.35 ; 2.00) = 2.00 \text{ cm}^2/\text{ml}$$

$$\text{We take : } 2\text{HA}12 = 2.26 \text{ cm}^2$$

**Case n°2 and case n°3 :**

$$N_{\max} = 69.56 \text{ T} \qquad M_{\text{corr}} = 42.03 \text{ T.m}$$

$$N_{\max} = 296.74 \text{ T} \qquad M_{\text{corr}} = 45.46 \text{ T.m}$$

Case n°1

$$\sigma_1 = \frac{N}{B} + \frac{M}{I}y = \frac{69.56 \times 10^{-2}}{1.1} + \frac{42.03 \times 10^{-2}}{2.77} \times 2.75 = 1.049 \text{ MPa}$$

$$\sigma_2 = \frac{N}{B} - \frac{M}{I}y = \frac{69.56 \times 10^{-2}}{1.1} - \frac{42.03 \times 10^{-2}}{2.77} \times 2.75 = 0.2150 \text{ MPa}$$

Case n°3

$$\sigma_1 = \frac{N}{B} + \frac{M}{I}y = \frac{296.74 \times 10^{-2}}{1.1} + \frac{45.46 \times 10^{-2}}{2.77} \times 2.75 = 3.148 \text{ MPa}$$

$$\sigma_2 = \frac{N}{B} - \frac{M}{I}y = \frac{296.74 \times 10^{-2}}{1.1} - \frac{45.46 \times 10^{-2}}{2.77} \times 2.75 = 2.246 \text{ MPa}$$

Case n°2 :  $\sigma_1 \geq 0$  And  $\sigma_2 \geq 0$  So the section is Fully compressed, No tense area.

Case n°3 :  $\sigma_1 \geq 0$  And  $\sigma_2 \geq 0$  So the section is Fully compressed, No tense area.

The current area is armed with the minimum required by **RPA 99 V 2003** :

$$A_{\min} = 0,15\% . a . L$$

$$\text{For 1 ml : } A_{s \min} = \frac{A_{\min}}{L}$$

$$D \leq \frac{1. a}{10(\text{mm})}$$

$$S_t < \min (30 \text{ cm} ; 1.5. a)$$

**Tab V.9 : Calculation result.**

	$\sigma_1(\text{MPa})$	$\sigma_2(\text{MPa})$	D (mm)	$S_t(\text{cm})$	$A_{s \text{ min}}$	$A_{s \text{ adop}}(\text{cm}^2)$
<b>Case n°2</b>	1.049	0.215	12	20	3.00	5HA12 = 5.65
<b>Case n°3</b>	3.148	2.246	12	20	3.00	5HA12 = 5.65

Shear stress design :

$$\tau = 1.4 \frac{1.4}{b \times d} = 1.4 \frac{84.85 \times 10^{-2}}{0.2 \times 1.53} = 3.88 \text{ MPa}$$

$$\bar{\tau}_u = 0.2f_{c \ 28} = 0.2 \times 25 = 5 \text{ MPa}$$

$$\tau = 3.88 \text{ MPa} < \bar{\tau}_u = 5, \text{ MPa} \dots \dots \dots \text{CV}$$

### V.7.5. Diagram of the reinforcement of the sail

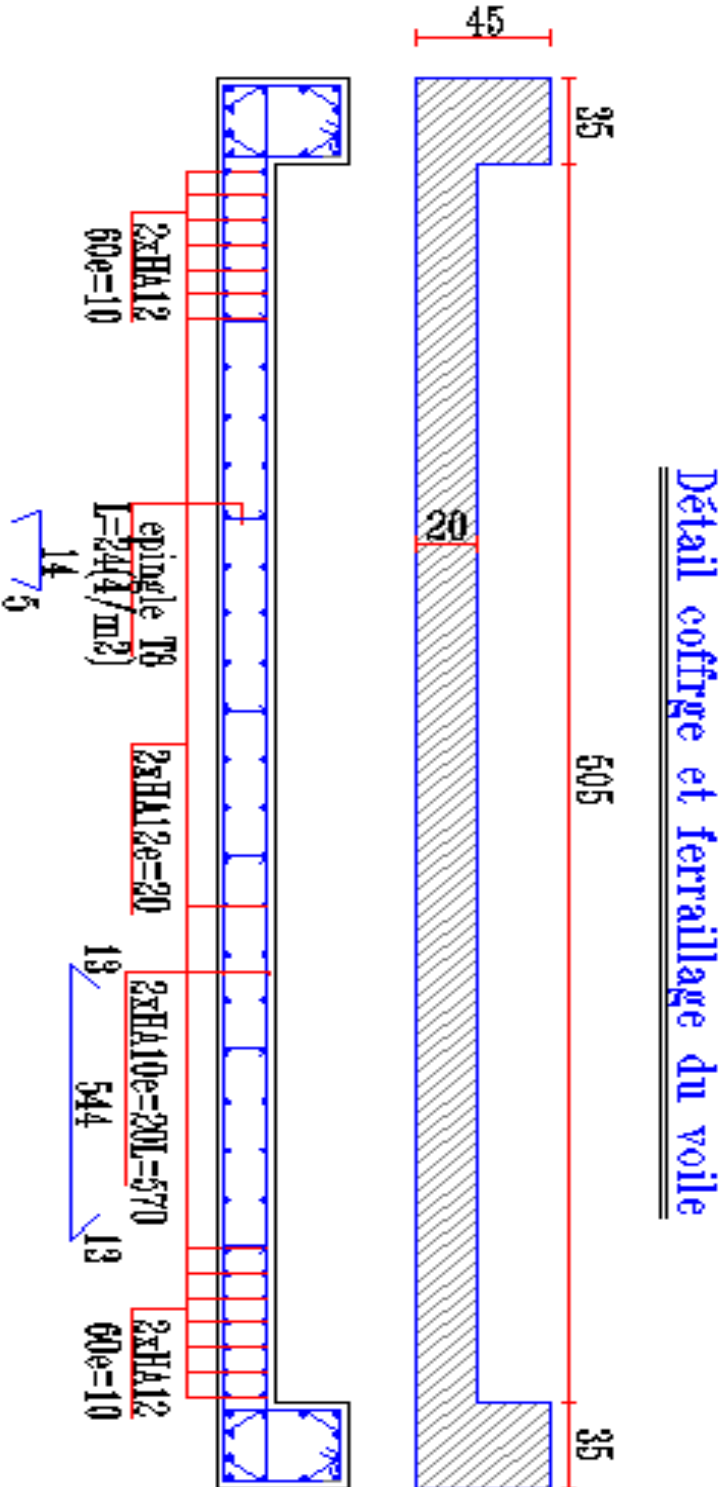

Figure V.24 :Diagram of the reinforcement of the sail

# CHAPTER VI

## **STUDY OF THE INFRASTRUCTURE**

## Study of the Infrastructure

### VI.1 Introduction :

Infrastructure is defined as the lower part of a structure resting on a foundation, which transmits all the loads supported by the structure, either directly (in the case of footings resting on the ground or raft foundations) or through other elements (as in the case of pile foundations, for instance). Therefore, they constitute the essential part of the structure.

There are several types of foundations, chosen based on the following conditions:

- ⇒ Bearing capacity of the soil.
- ⇒ Load to be transmitted to the soil.
- ⇒ Grid dimensions.
- ⇒ Anchor depth.
- ⇒ Distance between column axes.

The engineer must consider three essential concerns for the study of foundations:

- ⇒ The shape and location of the foundation.
- ⇒ The allowable stress of the soil must not be exceeded under any circumstances.
- ⇒ Settlement must be limited to prevent tilting or collapse of the structure.

### VI.2 Different types of foundations :

- ⇒ Shallow foundations (Isolated footing, Strip footing, Raft foundation).
- ⇒ Semi-deep foundations (Pile foundations).
- ⇒ Deep foundations (Piles).
- ⇒ Special foundations (Diaphragm walls and caissons).

In practice, there is a wide variety of foundations to choose from, considering factors such as soil heterogeneity, groundwater movements, diverse construction methods, and the influence of existing buildings on the underlying soil, all contributing to the complexity of foundation issues. The solution must satisfy two conditions:

⇒ The factor of safety against failure must be sufficient; foundation design involves failure analysis.

⇒ Settlements must be acceptable to avoid damage to the building. Variations in settlement can have varying degrees of severity depending on the nature of the construction. Additionally, settlement depends on the rigidity of the structure, which affects the distribution of forces at the foundation level.

### **VI.3 Calculation Combinations :**

The design of shallow foundations, according to the Algerian seismic regulation (RPA99/2003, Article 10.1.4.1), is performed under the following combinations:

⇒ Service ability Limit State (SLS) ( $G + Q$ ) for design purposes.

⇒ Ultimate Limit State (ULS) ( $1.35G + 1.5Q$ ) for reinforcement detailing.

⇒ Accidental conditions: ( $G + Q \pm E$ ) ; ( $0.8G \pm E$ ) for verification purposes.

### **VI.4 Soil Investigation :**

According to the soil report prepared by the Laboratory for Soil Analysis and Building Control (LHC EST), Hay El Match - Skikda Province, construction site

For shallow foundations with a width of anchored at a depth of  $D = 2\text{m}$ , the allowable stress of the soil is estimated to be 1 bars.

### **VI.5 Selection of Foundation Type :**

The choice of foundation type depends on :

⇒ Type of structure to be built.

⇒ Nature and homogeneity of the suitable soil.

⇒ Bearing capacity of the foundation soil.

⇒ Economic considerations.

⇒ Ease of construction.

⇒ Distance between column axes.

## VI.6 Calculation of the footing area :

We propose initially using strip footings. For this, we will proceed with a small verification:

The area of the footings must be less than 50% of the total area of the building:

$$(S_{\text{footings}}/S_{\text{building}} < 50\%)$$

### VI.6.1 Verification of the isolated footing :

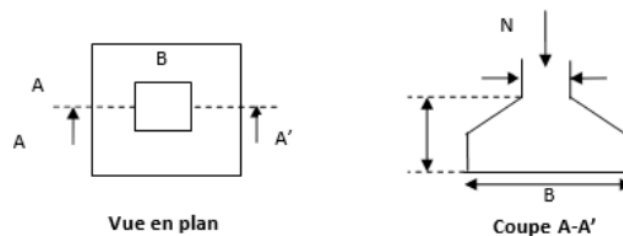

Figure VI.1 Isolated footing

In this project, we propose primarily using isolated footings. For this, we will proceed with an initial verification such as:

$$S \leq \frac{N_{ser}}{\bar{\sigma}_{sol}}$$

We will verify the most stressed footing:

$N$  : refers to the normal compressive force transmitted to the base.

$$N = 29865.2 \text{ KN}$$

$$\sigma_{sol} = 1 \text{ bar}$$

$S$  : represents the bearing area of the footing. It is calculated as  $S = A \times B$

$\sigma_{sol}$ : represents the allowable stress of the soil, denoted as  $\bar{\sigma}_{sol} = 0.80 \text{ bar}$

$$S = \frac{N_{ser}}{\sigma_{sol}} = \frac{29865.2}{1 \times 10^2} = 298.652 \text{ m}^2$$

$$S_b = 25.60 \times 21.10 = 540.16 \text{ m}^2$$

$$\frac{S}{S_b} \times 100 = \frac{298.652}{540.16} \times 100 = 55\%$$

## VI.7 Study of the raft foundation :

The raft foundation is a shallow foundation that functions like an inverted floor slab, with the slab resting on ribs. It ensures a good distribution of loads over the ground, making it an effective solution for preventing settlement.

The raft foundation is rigid in its horizontal plane, which allows for better distribution of the load on the foundation soil. In addition to being easy to form and quick to construct, it appears to be more suitable for mitigating potential issues that may arise from settlement over time.

A raft foundation is chosen in the following cases:

- ⇒ Poor soil conditions.
- ⇒ Significant loads transmitted to the soil.
- ⇒ Close spacing of columns (small column grids).

### Note:

There are 2 types of raft foundations (ribbed raft foundation; flat raft foundation)

⇒ Ribbed raft foundation is by far the most economical.

- 40 cm ≤ Slab thickness ≤ 1 m
- 50 cm ≤ Rib height ≤ 1.50 m

⇒ The flat raft foundation is not very economical.

- 70 cm ≤ Slab thickness ≤ 1.30 m

Thus, ribbed raft foundations are preferred over flat raft foundations.

### VI.7.1 Preliminary sizing of the raft slab :

The raft is considered infinitely rigid, so the following conditions must be satisfied:

#### VI.7.1.1 The lump sum condition:

$$\frac{L_{\max}}{35} \leq h \leq \frac{L_{\max}}{30}$$

With:

$L_{max}$ : The greatest span of the slab between supports.

$$L_{max} = 4.60 \text{ m.}$$

$$\frac{4.6}{35} = 13.14 \text{ cm} \leq h \leq \frac{4.6}{30} = 15.33 \text{ cm}$$

We adopt :  $h=15 \text{ cm}$

### VI.7.1.2 Shear strength condition:

The thickness of the raft will be determined based on the shear stress of the raft.

According to CBA93 (A.5.1.2.1) and (A.5.2.2)

$$\tau_u = \frac{T_{max}}{b \times d} \leq \bar{\tau} = \frac{0.07 \times f_{c28}}{\gamma_b}$$

With :

$T_{max}$ : Calculated value of the shear force at Ultimate Limit State (ULS).

$$b=1\text{m}$$

$$d=0,9*d$$

$$T_{max} = \frac{q_u \times L_{max}}{2} = \frac{N_u}{S} \times \frac{L_{max}}{2}$$

$$T_{max} = \frac{40931.1 \times 10^{-3}}{298.652} \times \frac{4.6}{2} = 0.315 \text{ MN} \Rightarrow 315.22 \text{ KN}$$

$$\bar{\tau} = \frac{0.07 \times f_{c28}}{\gamma_b} = \frac{0.07 \times 25}{1.5} = 1.17 \text{ Mpa}$$

$$d \geq \frac{T_{max}}{b \times \bar{\tau}} = \frac{315.22 \times 10^{-3}}{1 \times 1.17} = 0.269 \text{ m}$$

$$0.9 \times h \geq 0.269 \text{ m} \Rightarrow h \geq \frac{0.269}{0.9} = 0.298$$

We adopt :  $h=30 \text{ cm}$

## VI.7.2 Preliminary Sizing of the Rib :

The preliminary sizing requires the following checks:

### VI.7.2.1 Lump Sum Condition:

#### VI.7.2.1.1 Rib Height:

$$h_t \geq \frac{L_{\max}}{10}$$

$$h_t \geq \frac{460}{10} = 46 \text{ cm}$$

We adopt :  $h=50 \text{ cm}$

#### VI.7.2.1.2 Rib Width:

$$b_n \geq b_{\text{pot}}$$

$$b_n \geq 35$$

We adopt :  $b_0=40 \text{ cm}$

### VI.7.2.2 Elastic Length Condition:

To ensure linear stress distribution beneath the raft, the raft must be of rigid type. Therefore, the rib height must satisfy the condition:

$$L_{\max} \leq \frac{\pi}{2} \times L_e$$

$L_e$ : is the elastic length of the raft such that:

$$L_e \leq \sqrt[4]{\frac{4EI}{Kb}}$$

With :

I : Baseplate inertia

$$I = \frac{bh^3}{12}$$

- E: Elastic modulus of the soil taken as  $\Rightarrow E = 32164.20$  MPa.
- b: Width of the raft (1m strip).
- K: Soil stiffness coefficient,  $\Rightarrow K = 40$  MPa (medium density soil)

$$L_{\max} \leq \frac{\pi}{2} \times L_e = \frac{\pi}{2} \times \sqrt[4]{\frac{4EI}{Kb}}$$

$$ht^3 \geq \frac{2^2 \times 12 \times k \times b \times L_{\max}^4}{4 \times E \times \pi^4}$$

$$ht^3 \geq \sqrt[3]{\frac{16 \times 12 \times 40 \times 4.6}{4 \times 32164.20 \times 3.14^4}} = 0.650 \text{ cm}$$

We adopt :  $h_t = 70$  cm

Note: For reasons of economy, we will adopt a ribbed raft with:

$$h_{\text{raft}} = 30 \text{ cm} ; h_{\text{rib}} = 70 \text{ cm}$$

### VI.7.3 Overflow Calculation :

$$D = \max\left(\frac{h}{2} ; 30 \text{ cm}\right)$$

$$D = \max\left(\frac{30}{2} = 15 \text{ cm} ; 30 \text{ cm}\right)$$

We adopt :  $D=30$  cm

Therefore, the total area of the raft:

$$S_{\text{raft}} = S_{\text{building}} + (P \times D)$$

With :

S: Total surface area of the building.  $\Rightarrow S = 540.16 \text{ m}^2$

P: Perimeter length of the building.

$$\Rightarrow P = 2[(L_x + 2 \times D) + L_y] = 2 \times [(25.60 + 2 \times 30)] + 21.10 = 94.6 \text{ m}$$

$$S_{\text{raft}} = 540.16 + (94.6 \times 0.3) = 568.54 \text{ m}^2$$

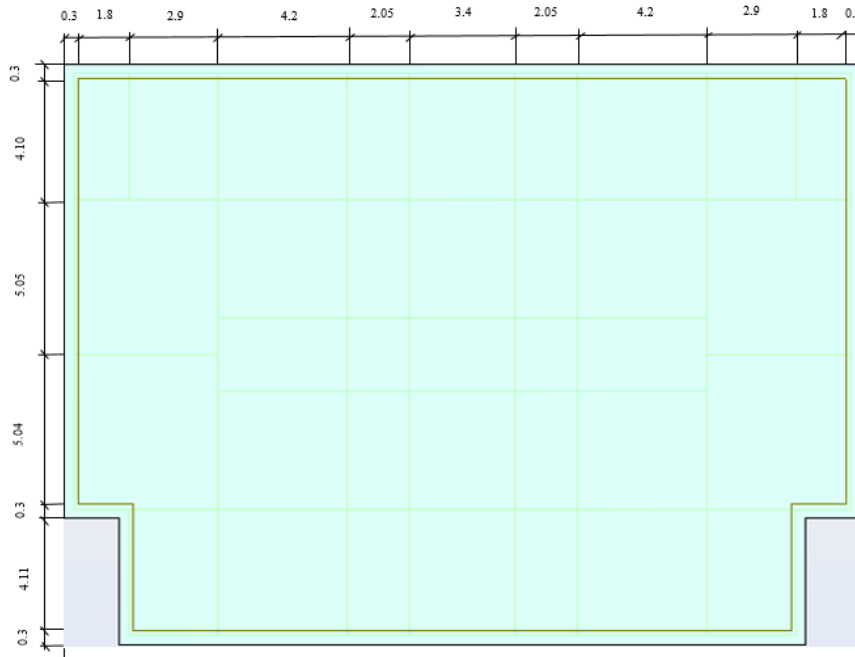

Figure VI.2 Raft surface

#### VI.7.4 Punching shear verification (CBA93 A.5.2.4.2) :

The punching shear occurs when a concrete block in the shape of a truncated cone at a 45-degree angle is expelled under the action of localized forces. It is necessary to verify the slab's resistance to punching shear due to these shear forces. This verification is carried out as follows:

$$Q_u \leq 0.045 \times \mu_c \times h_r \times \frac{f_{c28}}{\gamma_b}$$

With :

$Q_u$ : Design load with respect to the ultimate limit state of the most stressed column ( $b=35\text{cm}$ ;  $h=45\text{cm}$ ).

$\mu_c$ : Perimeter of the defined sheared contour.

$h_r$ : Total thickness of the raft slab.

$h_t$ : Total thickness of the rib.

$$\mu_c = 2 \times \left[ \left( b + 2 \times \frac{h_t}{2} \right) + \left( h + 2 \times \frac{h_t}{2} \right) \right]$$

$$\mu_c = 2 \times \left[ \left( 0.35 + 2 \times \frac{0.7}{2} \right) + \left( 0.45 + 2 \times \frac{0.7}{2} \right) \right] = 4.4 \text{ m}$$

$$Q_u \leq 0.045 \times 4.4 \times 0.3 \times \frac{25}{1.1} \times 10^3 = 1350 \text{ KN}$$

$$Q_u = 1106.6 \text{ KN} \leq 1350 \text{ KN} \dots \dots \text{ cv}$$

⇒ There is no risk of punching

### VI.7.5 Verification of non-lifting (pressure effect) :

It is necessary to justify the non-lifting of the building under the effect of hydrostatic pressure.

The following condition must be verified:

$$W_{\text{total}} \geq F_s \times \gamma_w \times Z \times S_{\text{raft}}$$

$$W_{\text{total}} = W_{\text{building}} + W_{\text{raft}}$$

$$W_{\text{building}} = 26303.2 \text{ KN}$$

$$W_{\text{raft}} = (S_{\text{raft}} \times h_r + S_{\text{rib}} \times (h_{\text{rib}} - h_{\text{raft}})) \times \rho_{\text{reinforced concrete}}$$

$$S_{\text{rib}} = S_{\text{rib } x} \times n + S_{\text{rib } y} \times n$$

$$S_{\text{rib } x} = b_n \times L_n = 0.4 \times 25.60 = 10.24 \text{ m}^2$$

$$S_{\text{rib } y} = b_n \times L_n = 0.4 \times 21.10 = 8.44 \text{ m}^2$$

$$S_{\text{rib}} = 10.24 \times 7 + 8.44 \times 10 = 156.08 \text{ m}^2$$

$$W_{\text{raft}} = (568.54 \times 0.3) + (156.08 \times (0.7 - 0.3)) \times 25 = 1731.36 \text{ m}^2$$

$$W_{\text{total}} = 26303.2 + 1731.36 = 28034.56 \text{ KN}$$

On the other hand:

F<sub>s</sub>: Safety coefficient with respect to uplift. ⇒ F<sub>s</sub> = 1.5

w: Density of water . ⇒ w = 10kn/m<sup>3</sup>

Z: Depth of the infrastructure . ⇒ Z = 2 m

$$W_{\text{total}} \geq F_s \times \gamma_w \times Z \times S_{\text{raft}}$$

$$28034.56 \text{ KN} \geq 1.5 \times 10 \times 2 \times 568.54 = 17056.2 \text{ KN} \dots \dots \text{ cv}$$

⇒ There is no risk of uprising

### VI.7.6 Geometric characteristics of the raft :

$$I_{gx} = \frac{L_x \times L_y^3}{12} \quad I_{gy} = \frac{L_y \times L_x^3}{12}$$

Tabl VI.1 Geometric characteristics of the raft

sign	Lx	Ly	S	Igx	Igy	Igx+Igy
1	2,9	4,1	11,89	16,656	8,33	24,989
2	4,2	4,1	17,22	24,122	25,31	49,436
3	4,7	5,05	23,735	50,442	43,69	94,134
4	4,2	3,95	16,59	21,570	24,39	45,958
5	2,05	3,95	8,0975	10,528	2,84	13,364
6	4,7	5,04	23,688	50,143	43,61	93,748
7	4,2	3,95	16,59	21,570	24,39	45,958
8	2,05	3,95	8,0975	10,53	2,84	13,36
9	4,2	2,1	8,82	3,24	12,97	16,21
10	2,05	2,1	4,305	1,58	1,51	3,09
11	2,9	4,11	11,919	16,78	8,35	25,13
12	4,2	4,11	17,262	24,30	25,38	49,67
13	3,4	2,1	7,14	2,62	6,88	9,50
14	3,4	4	13,6	18,13	13,10	31,23
15	2,9	4,1	11,89	16,66	8,33	24,99
16	4,2	4,1	17,22	24,12	25,31	49,44
17	4,7	5,05	23,735	50,44	43,69	94,13
18	4,2	3,95	16,59	21,57	24,39	45,96
19	2,05	3,95	8,0975	10,53	2,84	13,36
20	4,7	5,04	23,688	50,14	43,61	93,75
21	4,2	3,95	16,59	21,57	24,39	45,96
22	2,05	3,95	8,0975	10,53	2,84	13,36
23	4,2	2,1	8,82	3,24	12,97	16,21
24	2,05	2,1	4,305	1,58	1,51	3,09
25	2,9	4,11	11,919	16,78	8,35	25,13
26	4,2	4,11	17,262	24,30	25,38	49,67

$$D_x = X_{Gr} - X_i \quad \text{and} \quad D_y = Y_{Gr} - X_i$$

$$I_{rx} = I_{gx} + S_i \times D_{xi}^2 \quad \text{and} \quad I_{ry} = I_{gy} + S_i \times D_{yi}^2$$

Tabl VI.2 Inertia and Center of Gravity of the raft foundation.

sign	Xi	Yi	Si	Si*Xi	Si*Yi	Dx	Dy	Irx	Iry
1	3,25	17,57	57,103	185,5831	1003,2909	-2,57	-7,11	393,6213	2890,9256

2	6,80	17,57	119,476	812,4368	2099,1933	-6,80	-7,11	5548,6926	6056,5843
3	18,50	17,57	325,045	6013,3325	5711,0407	-18,50	-7,11	111297,0931	16452,2970
4	22,05	17,57	387,419	8542,5779	6806,9430	-22,05	-7,11	188385,4137	19581,6703
5	2,35	13,00	30,538	71,7649	396,8446	-2,35	-2,53	179,1759	198,3081
6	6,80	13,58	92,344	627,9392	1254,0315	-6,80	-3,12	4320,1293	939,6403
7	9,93	13,58	134,782	1337,7064	1830,3328	-9,93	-3,12	13298,3064	1332,2025
8	2,35	7,95	18,683	43,9039	148,5259	-2,35	2,52	113,7025	364,0220
9	6,80	7,36	50,048	340,3264	368,3533	-6,80	0,00	2317,4609	12,9654
10	9,93	7,36	73,048	725,0014	537,6333	-9,93	3,11	7197,2210	705,7652
11	6,80	10,47	71,162	483,9016	744,7103	-6,80	0	3307,3090	8,3532
12	4,82	9,93	47,839	230,5816	474,7971	-4,82	0,54	1135,7025	39,3248
13	3,25	3,38	10,969	35,6484	37,0195	-3,25	7,09	118,4814	558,2564
14	6,80	3,38	22,950	156,0600	77,4563	-6,80	7,09	1079,3413	1166,7542
15	12,25	10,47	128,196	1570,4041	1341,5738	-12,25	0,00	19254,1057	8,3329
16	12,25	7,36	90,160	1104,4600	663,5776	-12,25	3,11	13553,7574	894,5482
17	22,05	17,57	387,419	8542,5779	6806,9430	-22,05	-7,11	188414,2851	19600,9752
18	18,50	17,57	325,045	6013,3325	5711,0407	-18,50	-7,11	111268,2217	16432,9921
19	22,95	13,00	298,235	6844,4990	3875,5671	-22,95	-2,53	157091,7802	1911,8098
20	18,50	13,58	251,230	4647,7550	3411,7034	-18,50	-3,12	86033,6103	2481,3469
21	15,38	13,58	208,793	3210,1847	2835,4022	-15,38	-3,12	49378,1600	2050,3479
22	22,95	7,95	182,453	4187,2849	1450,4974	-22,95	2,52	96108,7163	1156,8889
23	18,50	7,36	136,160	2518,9600	1002,1376	-18,50	3,11	46604,0014	1325,6874
24	15,38	7,36	113,160	1739,8350	832,8576	-15,38	3,11	26751,5452	1092,4860
25	18,50	10,47	193,603	3581,6463	2026,0502	-18,50	0	66277,2337	8,3532
26	15,38	10,47	160,899	2473,8279	1683,8120	-15,38	0	38059,4031	25,3751
<b>Sum</b>			3916,755	66041,531	53131,334	<b>Sum</b>		1237486,470	97296,2131

#### VI.7.6.1 Center of gravity of the raft foundation masses :

$$X_{Gr} = \frac{\sum X_i S_i}{\sum S_i}; \quad Y_{Gr} = \frac{\sum Y_i S_i}{\sum S_i}$$

$$X_{Gr} = \frac{\sum X_i S_i}{\sum S_i} = \frac{66041.5313}{3916.755} = 16.86 \text{ m}$$

$$Y_{Gr} = \frac{\sum Y_i S_i}{\sum S_i} = \frac{53131.3348}{3916.755} = 13.56 \text{ m}$$

#### VI.7.6.2 Center of gravity of the building masses (superstructure) :

$$X_{Gb} = \frac{M_y}{F_z}; \quad Y_{Gb} = \frac{M_x}{F_z}$$

$$X_{Gb} = 12.65 \text{ m}; \quad Y_{Gb} = 10.72 \text{ m}$$

### VI.7.6.3 Determination of eccentricity :

$$e_x = |X_{Gb} - X_{Gr}| = 12.65 - 16.86 = 4.21\text{m}$$

$$e_y = |Y_{Gb} - Y_{Gr}| = 10.72 - 13.56 = 2.84\text{m}$$

### Conclusion:

The values of the center of masses of the superstructure and those relative to the raft are very close, therefore the effect of eccentricity is negligible, leading to a uniformly distributed soil reaction.

### VI.7.7 Determination of loads and surcharges :

$$N = N_{\text{raft}} + N_{\text{building}}$$

$$N = G_{\text{raft}} + G_{\text{rib}} + G_{\text{ground}} + G_{\text{building}} + Q$$

With :

$$G_{\text{raft}} = S_{\text{raft}} \times h \times \rho_{\text{reinforced concrete}} = 568.54 \times 0.3 \times 25 = 4264.05 \text{ KN}$$

$$h = h_{\text{rib}} - h_{\text{raft}} = 0.7 - 0.3 = 0.4 \text{ m}$$

$$G_{\text{rib}} = S_{\text{rib}} \times h \times \rho_{\text{rc}} = 156.08 \times 0.4 \times 25 = 1560.8 \text{ KN}$$

$$G_{\text{ground}} = \gamma_m [S_{\text{raft}} \times h_{\text{ground}} - (V_{\text{raft}} - V_{\text{rib}})] = 18 [568.54 \times 2 - (175.962 + 62.432)] = 16176.348 \text{ KN}$$

$$G_{\text{building}} = 25778.1 \text{ KN}$$

$$Q_{\text{building}} = 4087.2 \text{ KN}$$

$$N = G_{\text{raft}} + G_{\text{rib}} + G_{\text{ground}} + G_{\text{building}} + Q$$

$$N = 4264.05 + 1560.8 + 16176.348 + 25778.1 + 4087.2 = 51866.489 \text{ KN}$$

**VI.7.8 Check :****VI.7.9 Justification of foundation stability (A.5.7 RPA99/2003) :**

For the justification of foundation stability, reference should be made to the requirements for foundations and retaining structures.

Following A.10.1.5 of RPA99/2003: Verification of overturning stability: Regardless of the type of foundations (shallow or deep), it must be verified that the eccentricity of the resultant of gravitational vertical forces and seismic forces remains within the central half of the base of the foundation elements resisting overturning.

$$e = \frac{M}{N} \leq \frac{B}{4}$$

With :

e: The eccentricity of the resultant of vertical loads.

M: Moment due to seismic action (SLS).

N: Vertical load (SLS).

$$L_x = 25.60 \text{ m} ; L_y = 21.10 \text{ m}$$

$$X_{ccm} = 12.65 \text{ m} \quad Y_{ccm} = 11.25 \text{ m}$$

- **1st case according to X (L<sub>x</sub>=25.60m):**

$$X_{e1} = \frac{M_y}{N} = \frac{377795.0}{34129.25} = 11.06 \text{ m}$$

$$e_1 = 12.65 - 11.06 = 1.59 \text{ m} \leq \frac{25.6}{4} = 6.4 \text{ m}$$

- **2st case according to Y (L<sub>y</sub>=21.10m):**

$$Y_{e1} = \frac{M_x}{N} = \frac{317476.5}{34129.25} = 9.30 \text{ m}$$

$$e_2 = 11.25 - 9.30 = 1.95 \text{ m} \leq \frac{25.6}{4} = 5.27 \text{ m}$$

**VI.7.9.1 Verification of soil stress under vertical load :**

$$\sigma_{underraft} \leq 1.5 \times \overline{\sigma_{soil}}$$

$$\sigma_{\text{underraft}} = \frac{N}{S_{\text{raft}}} = 0.91 \text{ bar}$$

$$1.5 \times \overline{\sigma_{\text{soil}}} = 1.5 \times 1 = 1.5 \text{ bar}$$

$$0.91 \text{ bar} \leq 1.5 \text{ bar} \dots \text{cv}$$

### VI.7.9.2 Verification of compression under G+Q±E :

The constraints under the raft must satisfy the conditions:

$$\sigma_{\text{max}} = \frac{N}{S_{\text{raft}}} + \frac{M}{I_{xx}} X_G \leq 1.5 \times \overline{\sigma_{\text{soil}}}$$

$$\sigma_{\text{min}} = \frac{N}{S_{\text{raft}}} + \frac{M}{I_{yy}} Y_G \leq 1.5 \times \overline{\sigma_{\text{soil}}}$$

$$\sigma_{\text{moy}} = \frac{3 \times \sigma_{\text{max}} + \sigma_{\text{min}}}{4}$$

With :

$$N = 51866.489 \text{ KN}$$

$$I_{xx} = 1237486.47$$

$$I_{yy} = 9729621.31$$

$$X_{Gr} = 16.86 \text{ m}$$

$$Y_{Gr} = 13.56 \text{ m}$$

**According to X :**

$$\sigma_{\text{max}} = \frac{51866.498 \times 10^{-2}}{568.54} + \frac{51866.498 \times 10^{-2} \times 4.21}{1237486.47} \times 16.86 = 0.94 \text{ bar} \leq 1.5 \text{ bar. cv}$$

$$\sigma_{\text{min}} = \frac{51866.498 \times 10^{-2}}{568.54} - \frac{51866.498 \times 10^{-2} \times 4.21}{9729621.31} \times 16.86 = 0.90 \text{ bar} \leq 1.5 \text{ bar. cv}$$

$$\sigma_{\text{moy}} = \frac{3 \times (0.94 + 0.90)}{4} = 1.3 \leq 1.5 \text{ bar} \dots \dots \text{cv}$$

**According to Y :**

$$\sigma_{\max} = \frac{51866.498 \times 10^{-2}}{568.54} + \frac{51866.498 \times 10^{-2} \times 2.84}{1237486.47} \times 13.56 = 0.92 \text{ bar} \leq 1.5 \text{ bar. cv}$$

$$\sigma_{\min} = \frac{51866.498 \times 10^{-2}}{568.54} - \frac{51866.498 \times 10^{-2} \times 2.84}{9729621.31} \times 13.56 = 0.91 \text{ bar} \leq 1.5 \text{ bar. cv}$$

$$\sigma_{\text{moy}} = \frac{3 \times (0.92 + 0.91)}{4} = 1.3 \leq 1.5 \text{ bar ... cv}$$

⇒ The stability of the structure is ensured in both directions

### VI.7.10 Reinforcement of the raft :

The raft functions like an inverted floor whose supports are made up of the posts and the beams which are subjected to a uniform pressure coming from the own weight of the structure and the overloads. The panels constituting the raft are uniformly loaded and will be calculated as supported slabs on four sides and loaded by the stress of the ground, for this we use the method of BAEL91 appendix E3 to determine the unit moments  $\mu_x$ ,  $\mu_y$  which depend on the POISSON coefficient and the ratio :

$$\rho = \frac{L_x}{L_y}$$

⇒ In the sense of the small scope the moment is:  $M_x = \mu_x \times q \times l_x^2$

⇒ In the long-range direction the moment is:  $M_y = \mu_y \times q \times l_y^2$

Such as :

$\mu_x$  ;  $\mu_y$  ⇒ Are coefficients depending on  $\alpha = \frac{L_x}{L_y}$  and  $\nu$  (takes 0.2 at the SLS, 0 at the ULS)

For the calculation, we assume that the panels are partially embedded at the support levels from where we deduces the moments in span and the moments on supports. Cracking is considered detrimental, given that the raft can alternately be submerged and emerged in water. The calculation is done on a strip of width unit (1m).

#### VI.7.10.1 Evaluation of loads :

ULS :

$$q_u = \frac{N_{\text{ubuilding}} + 1.35N_{\text{raft}}}{S_{\text{raft}}} = \frac{40931.1 + 1.35 \times 4264.05}{568.54} = 82.118 \text{ KN}$$

**SLS :**

$$q_u = \frac{N_{\text{sbuilding}} + N_{\text{raft}}}{S_{\text{raft}}} = \frac{29865.2 + 4264.05}{568.54} = 60.029 \text{ KN}$$

⇒ We use the PIGEAUD method to determine the unit moments which depend on the Poisson coefficient and ratio:

$$\rho = \frac{3.85}{4.60} = 0.84$$

$$0.4 \leq \rho = 0.84 \leq 1$$

⇒ So the slab works in both directions

#### VI.7.10.2 Calculation of requests :

**ULS :  $\nu = 0$**

$$\rho = 0.84 \Rightarrow \begin{cases} \mu_x = 0.052 \\ \mu_y = 0.667 \end{cases}$$

$$M_x = \mu_x \times q \times l_x^2$$

$$M_x = 0.052 \times 82.11 \times 3.85^2 = 63.28 \text{ KN.m}$$

$$M_y = \mu_y \times M_x$$

$$M_y = 0.667 \times 63.28 = 42.20 \text{ KN.m}$$

**SLS :  $\nu = 0.2$**

$$\rho = 0.84 \Rightarrow \begin{cases} \mu_x = 0.058 \\ \mu_y = 0.764 \end{cases}$$

$$M_x = \mu_x \times q \times l_x^2$$

$$M_x = 0.058 \times 60.02 \times 3.85^2 = 52.40 \text{ KN.m}$$

$$M_y = \mu_y \times M_x$$

$$M_y = 0.764 \times 52.40 = 40.03 \text{ KN.m}$$

Therefore, the requests are:

In the span :  $M_t = 0.75 \times M_x = 0.75 \times M_y$

In the support :  $M_t = -0.5 \times M_x = -0.5 \times M_y$

The results are presented in the table:

**Tabl VI.3 Reinforcement moments of the raft slab**

	Span moment (KN.m)		Moment on support Fbc(MPa)	
	direction (x-x)	direction (Y-Y)	direction (x-x)	direction (Y-Y)
<b>ULS</b>	47.46	31.65	31.64	21.11
<b>SLS</b>	39.30	30.02	26.20	20.02

### VI.7.10.3 Calculation of reinforcements :

$$\mu = \frac{M_u}{b \times d^2 \times f_{bc}}$$

$$\alpha_u = 1.25 \times (1 - \sqrt{1 - 2\mu})$$

$$\beta_u = 0.8 \times \alpha_u$$

$$A_s = \beta_u \times b \times d \times \frac{f_{bc}}{\sigma_s}$$

We have :  $d = 0.9 \times h = 0.9 \times 30 = 27 \text{ cm}$

⇒ULS :

**Direction (XX) :**

**In span :**

$$\mu = \frac{47.46 \times 10^{-3}}{1 \times 0.27^2 \times 14.2} = 0.046$$

$$\mu = 0.046 \leq \mu_1 = 0.186 \Rightarrow \text{pivot A}$$

$$\mu = 0.046 \leq \mu_1 = 0.391 \Rightarrow A'_s = 0$$

$$\alpha_u = 1.25 \times (1 - \sqrt{1 - 2 \times 0.046}) = 0.059$$

$$\beta_u = 0.8 \times 0.059 = 0.047$$

$$A_s = 0.047 \times 1 \times 0.27 \times \frac{14.2}{348} = 5.18 \text{ cm}^2$$

**In support :**

$$\mu = \frac{31.64 \times 10^{-3}}{1 \times 0.27^2 \times 14.2} = 0.031$$

$$\mu = 0.031 \leq \mu_1 = 0.186 \Rightarrow \text{pivot A}$$

$$\mu = 0.031 \leq \mu_1 = 0.391 \Rightarrow A'_s = 0$$

$$\alpha_u = 1.25 \times (1 - \sqrt{1 - 2 \times 0.031}) = 0.039$$

$$\beta_u = 0.8 \times 0.039 = 0.0311$$

$$A_s = 0.0311 \times 1 \times 0.27 \times \frac{14.2}{348} = 3.42 \text{ cm}^2$$

**Direction (YY) :**

**In span :**

$$\mu = \frac{31.65 \times 10^{-3}}{1 \times 0.27^2 \times 14.2} = 0.031$$

$$\mu = 0.031 \leq \mu_1 = 0.186 \Rightarrow \text{pivot A}$$

$$\mu = 0.031 \leq \mu_1 = 0.391 \Rightarrow A'_s = 0$$

$$\alpha_u = 1.25 \times (1 - \sqrt{1 - 2 \times 0.031}) = 0.039$$

$$\beta_u = 0.8 \times 0.039 = 0.0311$$

$$A_s = 0.0311 \times 1 \times 0.27 \times \frac{14.2}{348} = 3.42 \text{ cm}^2$$

**In support :**

$$\mu = \frac{21.11 \times 10^{-3}}{1 \times 0.27^2 \times 14.2} = 0.020$$

$$\mu = 0.020 \leq \mu_1 = 0.186 \Rightarrow \text{pivot A}$$

$$\mu = 0.020 \leq \mu_1 = 0.391 \Rightarrow A'_s = 0$$

$$\alpha_u = 1.25 \times (1 - \sqrt{1 - 2 \times 0.020}) = 0.026$$

$$\beta_u = 0.8 \times 0.026 = 0.0207$$

$$A_s = 0.0207 \times 1 \times 0.27 \times \frac{14.2}{348} = 2.27 \text{ cm}^2$$

**Note:**

For high bond strength bars or wires of grade Fe E 400 or welded meshes with smooth wires of diameter greater than 6 mm (CBA99 art B.7.4):

$$A_{\min x} = 0.0008 \times b \times h \times \frac{3 - \rho}{2}$$

$$A_{\min y} = 0.0008 \times b \times h$$

**Direction (XX) :**

**In span :**

$$A_{\min x} = 0.0008 \times 1 \times 0.3 \times \frac{3 - 0.84}{2} = 2.60 \text{ cm}^2$$

**In support :**

$$A_{\min x} = 0.0008 \times 1 \times 0.3 \times \frac{3 - 0.84}{2} = 2.60 \text{ cm}^2$$

**Direction (YY) :**

**In span :**

$$A_{\min y} = 0.0008 \times 1 \times 0.3 = 2.40 \text{ cm}^2$$

**In support :**

$$A_{\min y} = 0.0008 \times 1 \times 0.3 = 2.40 \text{ cm}^2$$

**VI.7.10.4 Longitudinal reinforcement :**

**Direction (XX) :**

**In span :**

$$A_s = \max(A_s; A_{\min})$$

$$A_s = \max(5.18 \text{ cm}^2, 2.60 \text{ cm}^2) = 5.18 \text{ cm}^2$$

We adopt : **5HA12=5.65 cm<sup>2</sup>**

**In support :**

$$A_s = \max(A_s; A_{\min})$$

$$A_s = \max(3.42 \text{ cm}^2, 2.60 \text{ cm}^2) = 3.42 \text{ cm}^2$$

We adopt : **5HA12=5.65 cm<sup>2</sup>**

**Direction (YY) :**

**In span :**

$$A_s = \max(A_s; A_{\min})$$

$$A_s = \max(3.42 \text{ cm}^2, 2.40 \text{ cm}^2) = 3.42 \text{ cm}^2$$

We adopt : **5HA12=5.65 cm<sup>2</sup>**

**In support :**

$$A_s = \max(A_s; A_{\min})$$

$$A_s = \max(2.27 \text{ cm}^2, 2.40 \text{ cm}^2) = 2.40 \text{ cm}^2$$

We adopt : **5HA12=5.65 cm<sup>2</sup>**

**VI.7.10.5 Spacing of reinforcements :**

**In span :**

$$S_t \leq \min(3h; 33 \text{ cm})$$

We adopt : $S_t = 20$  cm

**In support :**

$$S_t \leq \min(3h; 33\text{cm})$$

We adopt : $S_t = 20$  cm

**VI.7.10.6 Transverse reinforcement :**

$$\tau = \frac{T_u}{b \times d} \leq \bar{\tau} = 0.07 \times \frac{f_{c28}}{\gamma_b}$$

$$\bar{\tau} = 0.07 \times \frac{25}{1.5} = 1.17 \text{ Mpa}$$

**Direction (XX) :**

$$T_{ux} = \frac{q_u \times L_x \times L_y}{2 \times L_x + L_y}$$

$$T_{ux} = \frac{82.11 \times 3.85 \times 4.60}{2 \times 3.85 + 4.60} = 118.24 \text{ KN}$$

$$\tau = \frac{118.24 \times 10^{-3}}{1 \times 0.27} = 0.44 \text{ Mpa}$$

$$\tau = 0.44 \text{ Mpa} \leq \bar{\tau} = 1.17 \text{ Mpa} \dots cv$$

**Direction (YY) :**

$$T_{uy} = \frac{q_u \times L_x}{3}$$

$$T_{uy} = \frac{82.11 \times 3.85}{3} = 105.38 \text{ KN}$$

$$\tau = \frac{105.38 \times 10^{-3}}{1 \times 0.27} = 0.39 \text{ Mpa}$$

$$\tau = 0.39 \text{ Mpa} \leq \bar{\tau} = 1.17 \text{ Mpa} \dots cv$$

**Therefore: Transverse reinforcement is not necessary**

**VI.7.10.7 Verification at the SLS :**

Cracking is detrimental, so the tensile stress of the reinforcements is limited, as is the case for elements exposed to weather conditions. It is necessary to check the stress in both the steel and the concrete.

**In concrete:**

$$\sigma_{bc} \leq \bar{\sigma}_{bc} = 0.06 \times f_{c28} = 15 \text{ Mpa}$$

**In steel :**

$$\sigma_s \leq \bar{\sigma}_s = \min \left( \frac{2}{3} f_e; 110 \sqrt{\eta f_{t28}} \right) = \min \left( \frac{2}{3} 400 ; 110 \sqrt{1.6 \times 2.1} \right) = 201.63 \text{ Mpa}$$

**Direction (XX) :**

**In span :**

**1-Calculation of the position of the neutral axis :**

$$b \times y^2 + 30 \times (A_s + A'_s) \times y - 30 \times (d \times A_s + d' + A''_s) = 0$$

$$A'_s = 0$$

$$100y^2 + 30 \times 5.65y - 30 \times 27 \times 5.65 = 0$$

$$100y^2 + 169.5y - 4576.5 = 0$$

$$\Delta = (169.5^2) + 4 \times (100) \times (4576.5) = 1859330.25$$

$$\sqrt{\Delta} = 1363.57$$

$$y_1 = -7.66$$

$$y_2 = 5.97$$

**2-Calculation of the moment of inertia :**

$$I = \frac{by^3}{3} + 15(A_s(d-y)^2 + A'_s \times (d' - y^2))$$

$$I = \frac{100 \times 5.97^3}{3} + 15(5.65 \times (27 - 5.97)^2) = 44574.1503 \text{ cm}^4$$

**3-Angular coefficient K :**

$$K = \frac{M_{ser}}{I} = \frac{39.30 \times 10^{-3}}{44574.1503 \times 10^{-8}} = 88.1676 \text{ MN/m}^3$$

**4-Checking the stress in the concrete :**

$$\sigma_{bc} = K \times y_{ser} = 88.1676 \times 0.0597 = 5.26 \text{ Mpa}$$

$$\sigma_{bc} = 5.26 \text{ Mpa} \leq \bar{\sigma}_{bc} = 15 \text{ Mpa} \dots \text{ cv}$$

**5-Checking the stress in the steel :**

$$\sigma_s = 15 K(d - y_{ser}) = 15 \times 88.1676 \times (0.27 - 0.0597) = 278.1246 \text{ Mpa}$$

$$\sigma_s = 278.1246 \text{ Mpa} \leq \bar{\sigma}_s = 201.63 \text{ Mpa} \dots \dots \text{ cv}$$

Tab. VI.4: Verification at the SLS

		$M_{ser}$	y(cm)	$I(m^4)$	$\sigma_{bc}(Mpa)$	Obs	$\sigma_s(Mpa)$	Obs
In span	XX	39,31	5.97	44574.15	5,26	cv	278,2	cnv
		30,03	5.97	44574.15	4,02	cv	212,5	cnv
In support	YY	26,20	5.97	44574.15	3,51	cv	185,4	cv
		20,02	5.97	44574.15	2,68	cv	141,7	cv

The tensile stress is not verified, so we must calculate the reinforcements using the SLS.

**Resizing:**

$$\mu_{ser} = \frac{30M_{ser}}{b \times d^2 \times \bar{\sigma}_s}$$

$$\mu_{ser} = \frac{30 \times 39.30 \times 10^{-3}}{1 \times 0.27^2 \times 201.63} = 0.080$$

$$\lambda = 1 + \mu$$

$$\cos\phi = \lambda^{-3/2}$$

$$\alpha = 1 + 2\sqrt{\lambda} \cos\left(240 + \frac{\phi}{3}\right)$$

$$\sigma_{bc} = \frac{\alpha \bar{\sigma}_s}{1 - \alpha \frac{\bar{\sigma}_s}{n}} A_s = \frac{\alpha \times b \times d \times \sigma_{bc}}{2 \times \bar{\sigma}_s}$$

Tab VI.5: The reinforcements at the SLS

		$M_{ser}$	$\mu_{ser}$	$\lambda$	$\phi$	$\alpha$	$\sigma_{bc}(Mpa)$	$A_s(cm^4)$	$A_s$ adopted	$S_t$
In span	XX	39.30	0080	1.080	21.65	0.206	3.49	4.81	5HA12	20
		30.03	0.061	1.061	18	0.173	2.81	3.88	5HA12	20

### VI.7.11 Study of overflow :

The cantilever of the raft is considered as a 50 cm long console, and the reinforcement calculation is carried out over a strip of 1m width.

Tab VI.6 Overflow characteristics

b(cm)	h(cm)	d(cm)	L(cm)	$q_u(Kn/m)$	$q_{ser}(Kn/m)$
100	30	28	30	82.12	60.02

#### VI.7.11.1 Reinforcement calculation :

$$M_{\max} = \frac{q l^2}{2}$$

$$M_{\max} = \frac{82.12 \times (0.30)^2}{2} = 3.61 \text{ KN.m}$$

$$\mu = \frac{M_{\max}}{b \times d \times f_{c28}}$$

$$\mu = \frac{3.61}{1 \times 0.28^2 \times 14.2} = 0.0036$$

$$\mu = 0.036 \leq \mu_1 = 0.186 \Rightarrow \text{pivot A}$$

$$\mu = 0.036 \leq \mu_1 = 0.391 \Rightarrow A'_s = 0$$

$$\alpha_u = 1.25 \times (1 - \sqrt{1 - 2 \times 0.036}) = 0.0048$$

$$\beta_u = 0.8 \times 0.0048 = 0.0035$$

$$A_s = 0.0035 \times 1 \times 0.27 \times \frac{14.2}{348} = 0.39 \text{ cm}^2$$

**VI.7.11.2 Condition of non-fragility :**

$$A_{\min} = 0.23 \times b \times d \times \frac{f_{t28}}{f_e}$$

$$A_{\min} = 0.23 \times 1 \times 0.27 \times \frac{2.1}{400} = 3.26 \text{ cm}^2$$

**VI.7.11.3 Longitudinal reinforcements :**

$$A_s = \max(A_s; A_{\min})$$

$$A_s = \max(0.39; 3.26) = 3.26 \text{ cm}^2$$

We adopt : **5HA12=5.65cm<sup>2</sup>**

**VI.7.11.4 Verification of the shear force :**

$$\tau = \frac{T_u}{b \times d} \leq \bar{\tau} = 2.5 \text{ Mpa}$$

$$\bar{\tau} = 0.07 \times \frac{25}{1.5} = 1.17 \text{ Mpa}$$

$$T_u = \frac{q l}{2} = \frac{82.12 \times 0.30}{2} = 12.32 \text{ KN}$$

$$\tau = \frac{12.32 \times 10^{-3}}{1 \times 0.27} = 0.05 \text{ Mpa}$$

$$\tau = 0.05 \leq \bar{\tau} = 2.5 \text{ Mpa} \dots \text{cv}$$

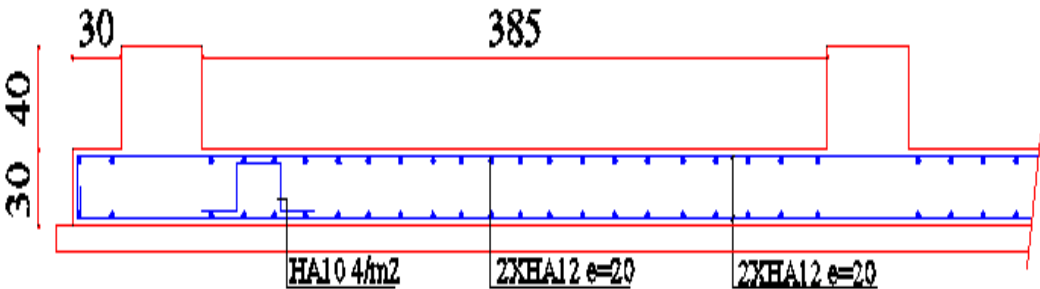

Figure VI.3 Reinforcement of the slab in x-x direction

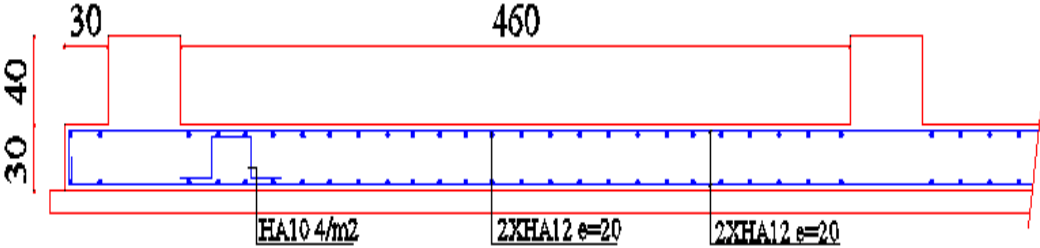

Figure VI.4 Reinforcement of the slab in Y-Y direction

**□.8. Reinforcement of the ribs :**

The ribs serve as supports for the slab of the slab, thus the transmission of loads Is carried out according to the breaklines.

**□.8.1. Rib loads :**

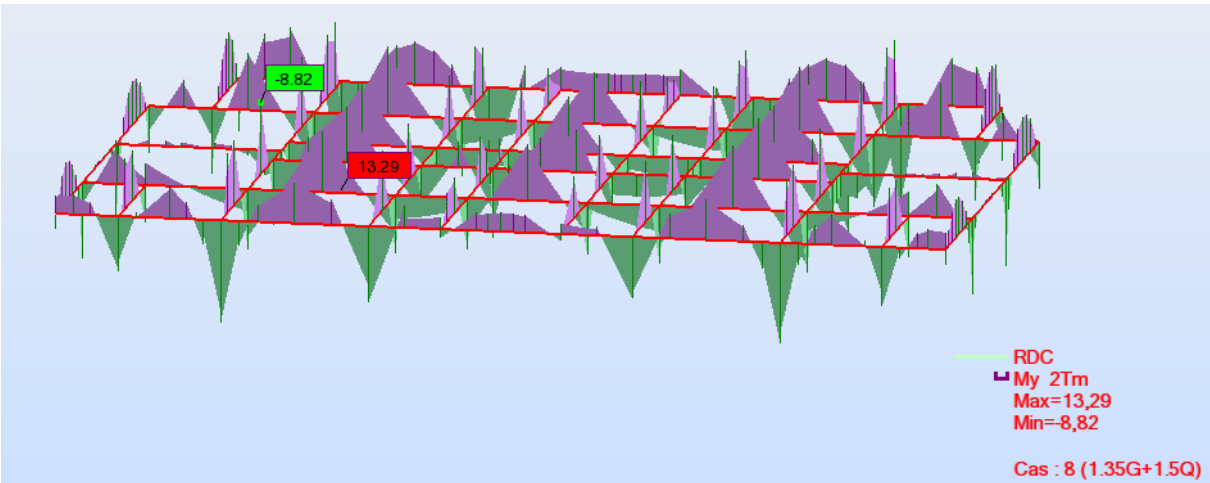

Figure VI: Rib loads in ULS

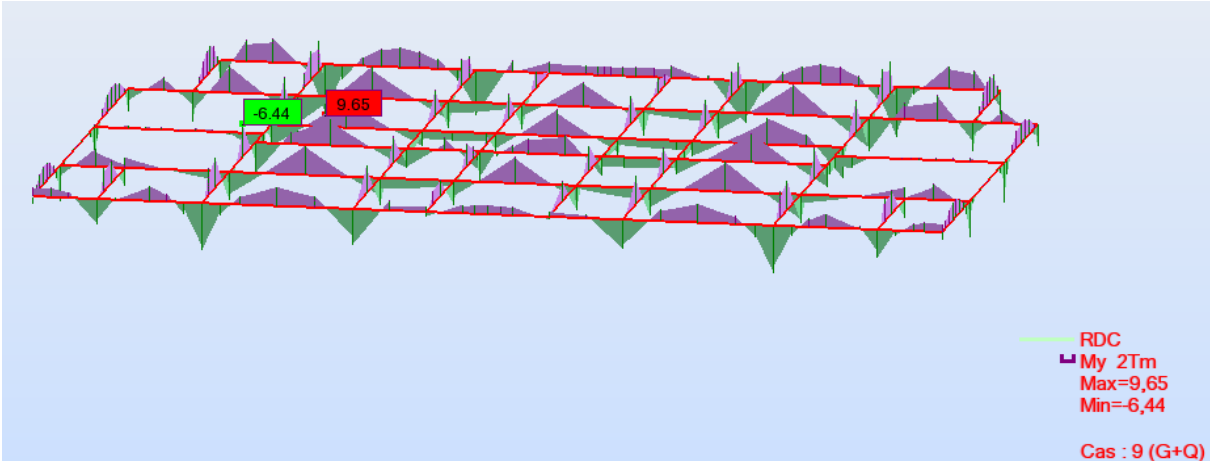

Figure VI: Rib loads in SLS

**Tableau VI.1 : Summary of requests**

Situation	Span	Support
-----------	------	---------

<b>ULS</b>	$M_{\text{span}} = -88.2 \text{ KN. m}$	$M_{\text{support}} = 132.9 \text{ KN. m}$
<b>SLS</b>	$M_{\text{span}} = -64.4 \text{ KN. m}$	$M_{\text{support}} = 96.5 \text{ KN. m}$

### □.8.2. Calculation of reinforcement :

➤ In span :

**U.L.S :**  $M_{\text{span}} = -88.2 \text{ Kn. m}$

$$d = 0.9 \times h = 0.9 \times 0.70 = 0.63 \text{ m}$$

$$\mu = \frac{M_{\text{span}}^u}{b \cdot d^2 \cdot f_{bc}} = \frac{88.2 \times 10^{-3}}{0.40 \times 0.63^2 \times 14.2} = 0.0391 < \mu_{\text{limit}} = 0.391 \rightarrow A' = 0$$

$$\mu = 0.0391 < 0.186 \rightarrow \text{pivot A}$$

$$\alpha_u = 1.25 \times (1 - \sqrt{1 - 2\mu}) = 1.25 \times (1 - \sqrt{1 - 2 \times 0.0391}) = 0.049$$

$$A_s = 0.8 \cdot \alpha_u \cdot b \cdot d \cdot \frac{f_{bc}}{\sigma_s} = \frac{0.8 \times 0.049 \times 0.40 \times 0.63 \times 14.2}{348} = 4.030 \times 10^{-4} \text{ m}^2$$

$$= 4.030 \text{ cm}^2 \quad \text{We take : 4HA14} = 6.16 \text{ cm}^2$$

➤ In support :

**U.L.S :**  $M_{\text{support}} = 132.9 \text{ Kn. m}$

$$\mu = \frac{M_{\text{support}}^u}{b \cdot d^2 \cdot f_{bc}} = \frac{132.9 \times 10^{-3}}{0.40 \times 0.63^2 \times 14.2} = 0.058 < \mu_{\text{limit}} = 0.391 \rightarrow A' = 0$$

$$\mu = 0.058 < 0.186 \rightarrow \text{pivot A}$$

$$\alpha_u = 1.25 \times (1 - \sqrt{1 - 2\mu}) = 1.25 \times (1 - \sqrt{1 - 2 \times 0.058}) = 0.0747$$

$$A_s = 0.8 \cdot \alpha_u \cdot b \cdot d \cdot \frac{f_{bc}}{\sigma_s} = \frac{0.8 \times 0.0747 \times 0.40 \times 0.63 \times 14.2}{348} = 6.144 \times 10^{-4} \text{ m}^2$$

$$= 6.144 \text{ cm}^2 \quad \text{We take : 4HA16} = 8.04 \text{ cm}^2$$

□.8.3. Verification required :

- Non-frailty condition : .... (CBA93 Art A.4.2)

It is necessary to check that:  $A_s \geq A_{s \min}$

$$A_{s \min} = \frac{0.23 \cdot b \cdot d \cdot f_{t28}}{f_e} = \frac{0.23 \times 0.40 \times 0.63 \times 2.1}{400} = 3.04 \times 10^{-4} \text{m}^2 = 3.04 \text{ cm}^2$$

$$A_{s \text{ span}} = 4.030 \text{ cm}^2 > A_{s \min} = 3.04 \text{ cm}^2 \dots\dots\dots \text{CV}$$

$$A_{s \text{ support}} = 6.144 \text{ cm}^2 > A_{s \min} = 3.04 \text{ cm}^2 \dots\dots\dots \text{CV}$$

So : we take :  $A_{s \text{ span}} = 4\text{HA}14 = 6.16 \text{ cm}^2$

And :  $A_{s \text{ support}} = 6\text{HA}14 = 9.24 \text{ cm}^2$

- Verification of longitudinal reinforcement according to the (RPA 99/V2003 Art 7.5.2.1) :

→ The minimum total percentage of longitudinal steels along the entire length of the beam is 0.5% in any section.

$$A_{\min \text{ RPA}} = 0.5\% \text{ b h} = 0.005 \times 40 \times 40 = 14 \text{ cm}^2$$

$$A_s = 4\text{HA}14 + 6\text{HA}14 = 15.40 \text{ cm}^2$$

$$A_s = 15.40 \text{ cm}^2 > A_{\min} = 14 \text{ cm}^2 \dots\dots\dots \text{CV}$$

→ The maximum total percentage of longitudinal steels is :

❖ Current area :

$$A_{s \max \text{ RPA}} = 4\% \text{ b h} = 0.04 \times 40 \times 70 = 112 \text{ cm}^2$$

$$A_{s \text{ span}} = 4\text{HA}14 + 6\text{HA}14 = 15.40 \text{ cm}^2$$

$$A_{s \text{ span}} = 15.40 \text{ cm}^2 < A_{\max} = 112 \text{ cm}^2 \dots\dots\dots \text{CV}$$

❖ Overlay area :

$$A_{s \max RPA} = 6\% b h = 0.06 \times 40 \times 70 = 168 \text{ cm}^2$$

$$A_s = 4HA14 + 6HA14 = 15.40 \text{ cm}^2$$

$$A_{s \text{ span}} = 15.40 \text{ cm}^2 < A_{\max} = 168 \text{ cm}^2 \dots\dots\dots CV$$

→ The minimum length of cover for Zone IIa is :

$$L_{\text{collection}} = 40\emptyset = 40 \times 1.4 = 56 \text{ cm} \quad \text{We take : 60 cm}$$

- Verification S.L.S :

The following should be checked :

**For a concret :**

$$\sigma_{bc} \leq \bar{\sigma}_s = 0.6 \times f_{c28} = 15 \text{ Mpa}$$

**For steel :**

Cracking is detrimental so the tensile stress of the reinforcement is limited, this is the case for elements exposed to the weather.

$$\sigma_s \leq \bar{\sigma}_s = \min\left\{\frac{2}{3} \times f_e; 110\sqrt{\eta \times f_{t28}}\right\}$$

$$\sigma_s = 201.63 \text{ Mpa}$$

$$\sigma_s = 15 \times k \times (d - y)$$

The results are summarized in the table :

Tableau □ : verification of the rib of the slab at the SLS in the X-X direction.

	$M_{\text{ser}}$	y (cm)	I (cm <sup>4</sup> )	K	$\sigma_{bc}$	Obc	$\sigma_s$	Obc
In span	64.4	14.91	257883.534	24.97	3.72	CV	180.121	CV
In support	96.5	16.71	357979.44	26.95	4.78	CV	182.96	CV

- Verification of the shear condition : (CBA93 Art A.5.1)

### Minimally damaging cracking

It must be checked that :  $\tau_u < \bar{\tau}_u$

$$T_u = 24.60 \text{ T. m} \quad \Leftrightarrow 246.00 \text{ Kn. m}$$

$$\tau_u = \frac{T_u}{b \cdot d} = \frac{246.00 \times 10^{-3}}{0.40 \times 0.63} = 0.976 \text{ MN. m}$$

$$\bar{\tau}_u = \min \left\{ 0.15 \frac{f_{c28}}{\gamma_b} ; 5 \text{ MPa} \right\} = \min \left\{ \frac{0.15 \times 25}{1.5} = 2.5 \text{ MPa} ; 4 \text{ MPa} \right\}$$

$$\bar{\tau}_u = 2.5 \text{ MPA}$$

$$0.976 \text{ MPA} < 2.5 \text{ MPA} \dots\dots\dots \text{CV}$$

1) Transverse reinforcement :

Diameter : You have to check :  $\emptyset_{tr} \leq \min \left\{ \frac{h}{35} ; \frac{b}{10} ; \emptyset_1 \right\}$

$$\emptyset_{tr} \leq \min \left\{ \frac{70}{35} ; \frac{40}{10} ; 1.4 \right\}$$

$$\emptyset_{tr} \leq \min \{ 2 ; 4 ; 1.4 \} = 1.4 \text{ cm} = 14 \text{ mm} \quad \rightarrow \quad \text{We take : } \emptyset_{tr} = 8 \text{ mm}$$

Spacing :

**Nodal area :**

$$S_t \leq \min \left\{ \frac{h}{4} ; 10\emptyset_1 ; 30\text{cm} \right\}$$

$$S_t \leq \min \left\{ \frac{70}{4} = 17.5 \text{ cm} ; 10 \times 1.4 = 14 \text{ cm} ; 30\text{cm} \right\} = 14 \text{ cm}$$

We take :  $S_t = 10 \text{ cm}$

**Current area :**

$$S_t \leq \frac{h}{2} = \frac{70}{2} = 35 \text{ cm}$$

We take :  $S_t = 20 \text{ cm}$

The cross-section of the transverse reinforcement :

**Nodal area :**

$$A_t \geq 0.3\% S b$$

$$A_t \geq 0.003 \times 10 \times 40 = 1.2 \text{ cm}^2$$

**Current area :**

$$A_t \geq 0.3\% S b$$

$$A_t \geq 0.003 \times 20 \times 40 = 2.4 \text{ cm}^2$$

We take :  $A_t = 4T10 = 3.14 \text{ cm}^2$

$$A_{t \text{ adopt}} = 3.14 \text{ cm}^2 > A_{t \text{ calc}} = 1.2 \text{ cm}^2 \dots\dots\dots CV$$

$$A_{t \text{ adopt}} = 3.14 \text{ cm}^2 > A_{t \text{ calc}} = 2.4 \text{ cm}^2 \dots\dots\dots CV$$

2) Reinforcement of skin :

Given the importance of the height of the ribs, it is necessary to put skin reinforcement in order to prevent cracking of the concrete.

According to CBA93 (Art A.7.3), leur section est d'au moins  $3 \text{ cm}^2$  per metre of height.

$$A_p = 3 \times h = 3 \times 0.70 = 2.1 \text{ cm}^2$$

We take :  $2HA12 = 2.26 \text{ cm}^2$

□.8.4. Rib reinforcement diagram :

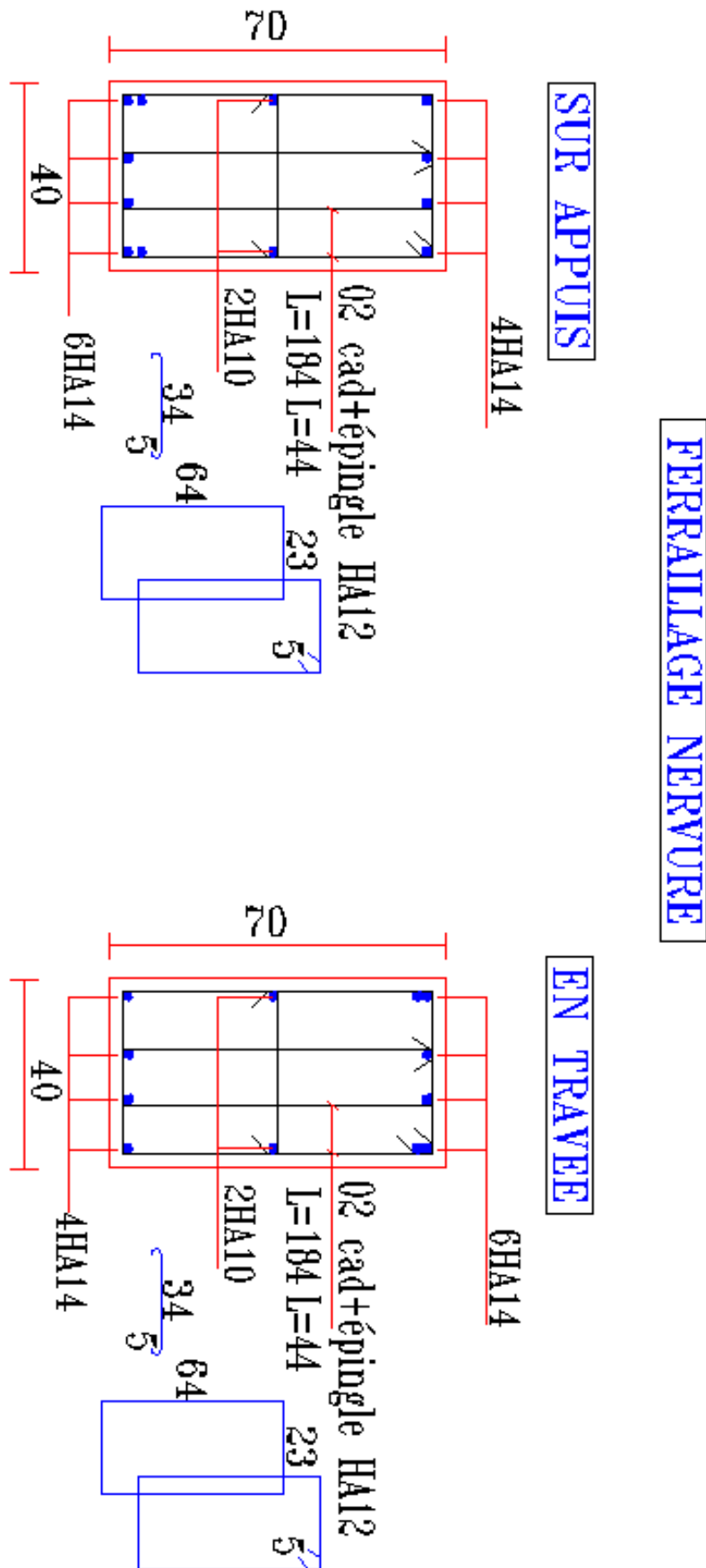

Figure VI: VI8.4. Rib reinforcement diagram :

## **General conclusion**

Civil engineering is a field that satisfies the needs of modern life and in this project allowed us on one side to assimilate the different techniques and This page acquired during the past two of design and can the calculation software and knowledge and governing the principles of design and calculation of structures in the building sector.

According to the modeling part using the ROBOT2010 software, we did analysis of the structure and proposed suitable solutions to have a good behavior of the structure in medium seismic zone, and stability and security of the work without forgetting about the economic part.

This project has carried out work that consists of designing and studying a building for residential and commercial use (G+5). For this project, we mainly acted on

Two plans :

- ❖ On the one hand (stability) the bracing and arrangement of the sails; We have found that the arrangement of the sails is an important factor in ensuring stability and safety structures.
- ❖ And on the other hand (economy) the estimation of the quantities of concrete and steel required. In Indeed, the pre-dimensioning resulted in non-economic column sections.

We did this study in order to achieve two objectives :

- Good stability structure.
- Economic structure.

And the end we can say this project for us a first experience, But a basis for the accumulation of experience, the acquisition of intuition and the development of the inventive thinking of the engineer.

## **REGULATION :**

- **RPA99V2003**: Algerian seismic regulations.
- **DTR B.C.2.2** : Permanent Loads and operating Load.
- **CBA93** : rules for desing and calculation of reinforced concret structures.
- **BAEL91** : reinforced concrete and live loads.

## **FINAL DISSERTATIONS :**

- Study of residential building UG + G + 14

University from 20 August 55 Skikda (Class of 2019)

- Etude d'un Bâtiment R+6 en béton armé à usage multiples contreventé par un système de voiles porteurs.

University from 20 August 55 Skikda (Class of 2022)

- Study of building with base + five story Analyse with real accelerograph (Earthquake of El Harrouch Skikda 2020).

## **COURS :**

- Cour Béton Armé Dr S. BOUZIANE.
- Exercises stairs td M. MENDJEL

## **BOOK :**

- BAEL 91 modifie 99, DTU associes, jean pierre mougine deuxième Edition PARIS...2000

## **SOFTWARE AND PROGRAMS :**

- ROBOT structural analysis software version 2010. (Structural analysis).
- AUTO CAD 2014. (Drawing).
- Word 2013. (Text processing).
- Excel 2013.

- Reinforcement tables

Section en cm<sup>2</sup> de 1 à 20 armatures de diamètre Ø en mm

Ø	5	6	8	10	12	14	16	20	25	32	40
1	0,20	0,28	0,50	0,79	1,13	1,54	2,01	3,14	4,91	8,04	12,57
2	0,39	0,57	1,01	1,57	2,26	3,08	4,02	6,28	9,82	16,08	25,13
3	0,59	0,85	1,51	2,36	3,39	4,62	6,03	9,42	14,73	24,13	37,70
4	0,79	1,13	2,01	3,14	4,52	6,16	8,04	12,57	19,64	32,17	50,27
5	0,98	1,41	2,51	3,93	5,65	7,70	10,05	15,71	24,54	40,21	62,83
6	1,18	1,70	3,02	4,71	6,79	9,24	12,06	18,85	29,45	48,25	75,40
7	1,37	1,98	3,52	5,50	7,92	10,78	14,07	21,99	34,36	56,30	87,96
8	1,57	2,26	4,02	6,28	9,05	12,32	16,08	25,13	39,27	64,34	100,5
9	1,77	2,54	4,52	7,07	10,18	13,85	18,10	28,27	44,18	72,38	113,1
10	1,96	2,83	5,03	7,85	11,31	15,39	20,11	31,42	49,09	80,42	125,7
11	2,16	3,11	5,53	8,64	12,44	16,93	22,12	34,56	54,00	88,47	138,2
12	2,36	3,39	6,03	9,42	13,57	18,47	24,13	37,70	58,91	96,51	150,8
13	2,55	3,68	6,53	10,21	14,70	20,01	26,14	40,84	63,81	104,6	163,4
14	2,75	3,96	7,04	11,00	15,83	21,55	28,15	43,98	68,72	112,6	175,9
15	2,95	4,24	7,54	11,78	16,96	23,09	30,16	47,12	73,63	120,6	188,5
16	3,14	4,52	8,04	12,57	18,10	24,63	32,17	50,27	78,54	128,7	201,1
17	3,34	4,81	8,55	13,35	19,23	26,17	34,18	53,41	83,45	136,7	213,6
18	3,53	5,09	9,05	14,14	20,36	27,71	36,19	56,55	88,36	144,8	226,2
19	3,73	5,37	9,55	14,92	21,49	29,25	38,20	59,69	92,27	152,8	238,8
20	3,93	5,65	10,05	15,71	22,62	30,79	40,21	62,83	98,17	160,8	251,3

Section en cm<sup>2</sup> de 1 à 20 armatures de diamètre  $\phi$  en mm.

- Values of  $\alpha_l$  and  $\mu_l$  depending on the grade of the steels

Nuance $f_e$ (MPa)	$\frac{f_e}{\gamma_s}$ (MPa)	$\epsilon_{se}$	$\alpha_l$	$\mu_l$
Fe E 215	189	0,935	0,789	0,429
Fe E 235	204	1,022	0,774	0,425
Fe E 400	348	1,739	0,668	0,391
Fe E 500	435	2,174	0,617	0,371

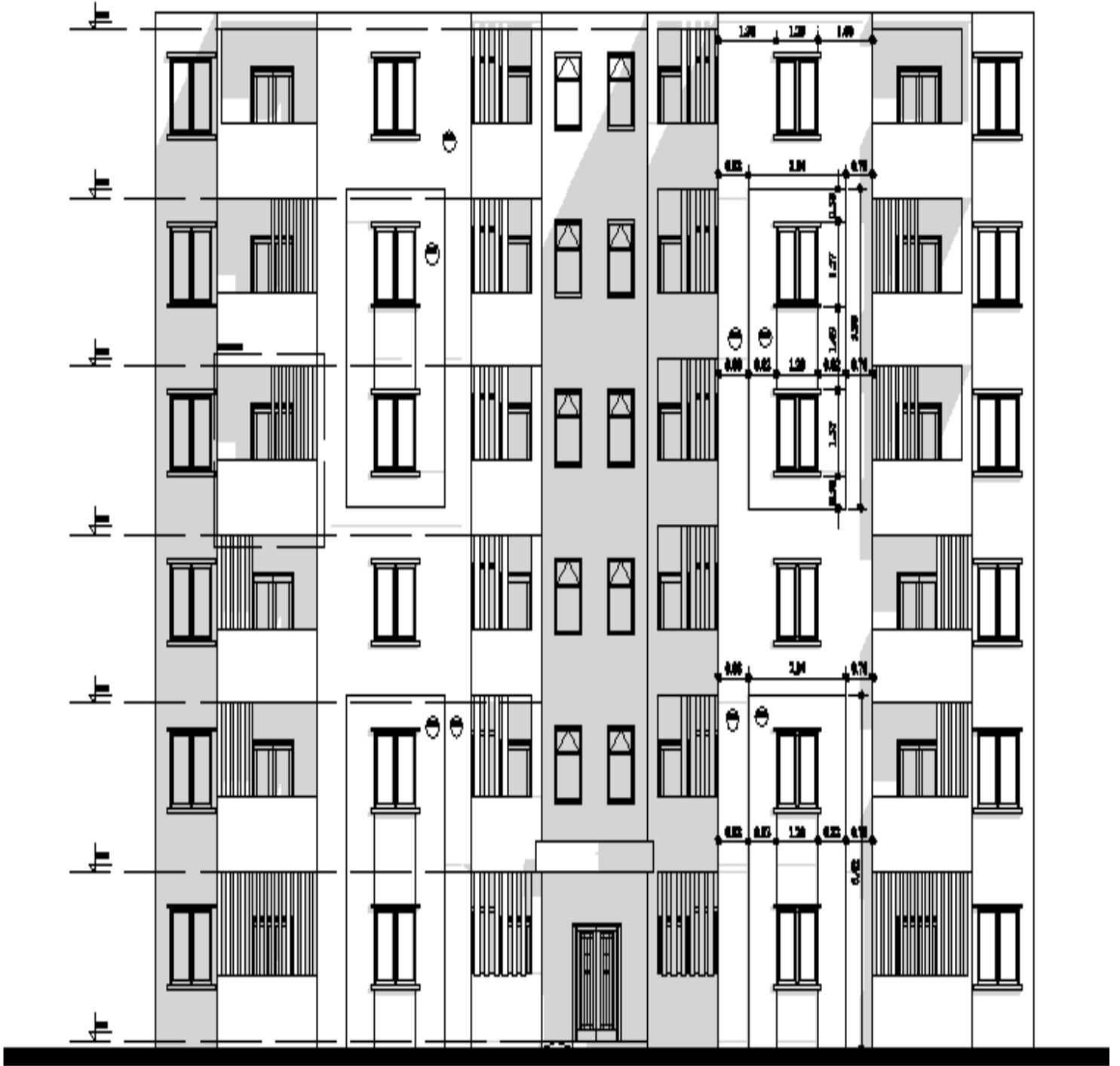

FACADE PRINCIPALE

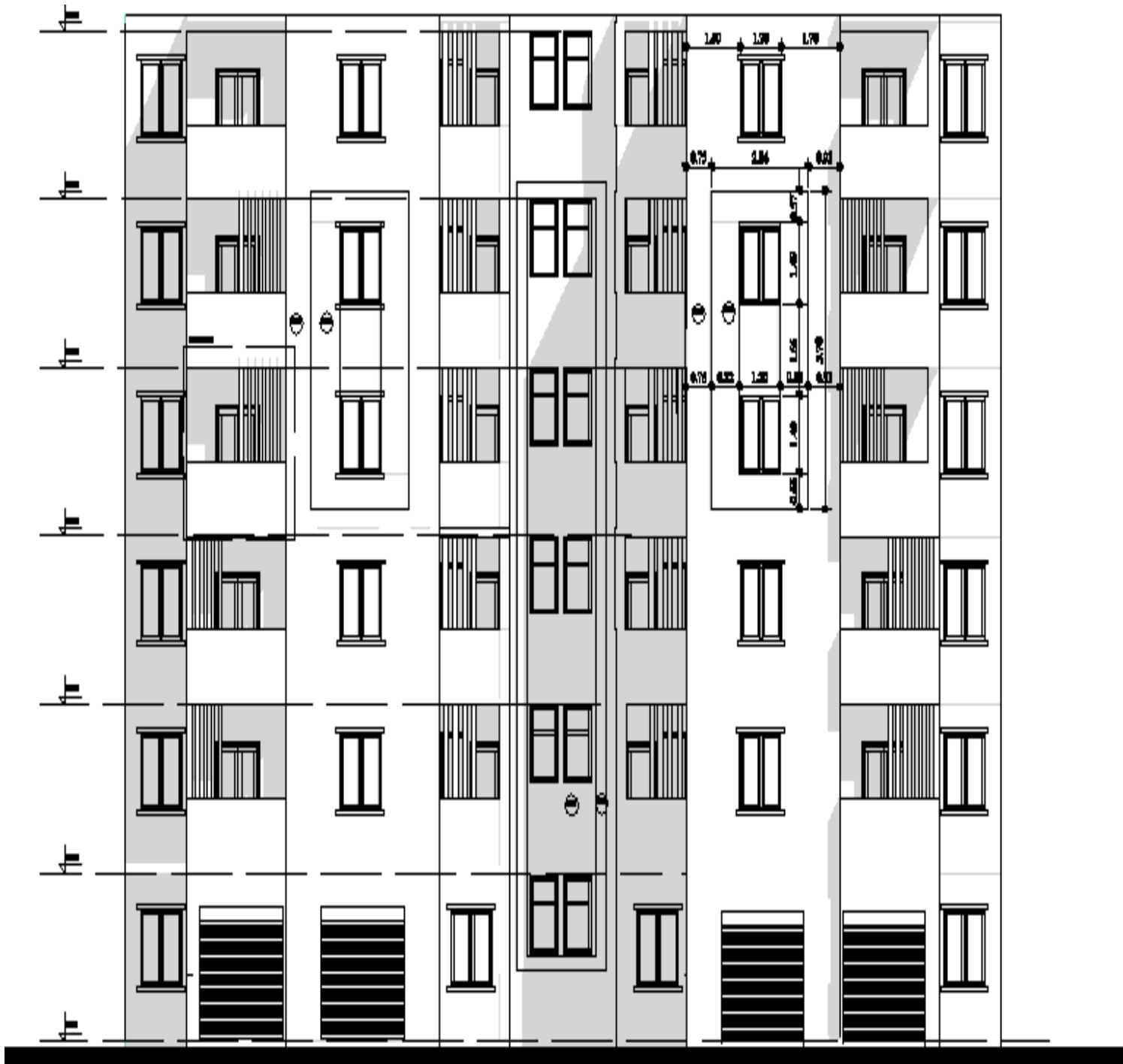

FACADE PROSTERIEUR

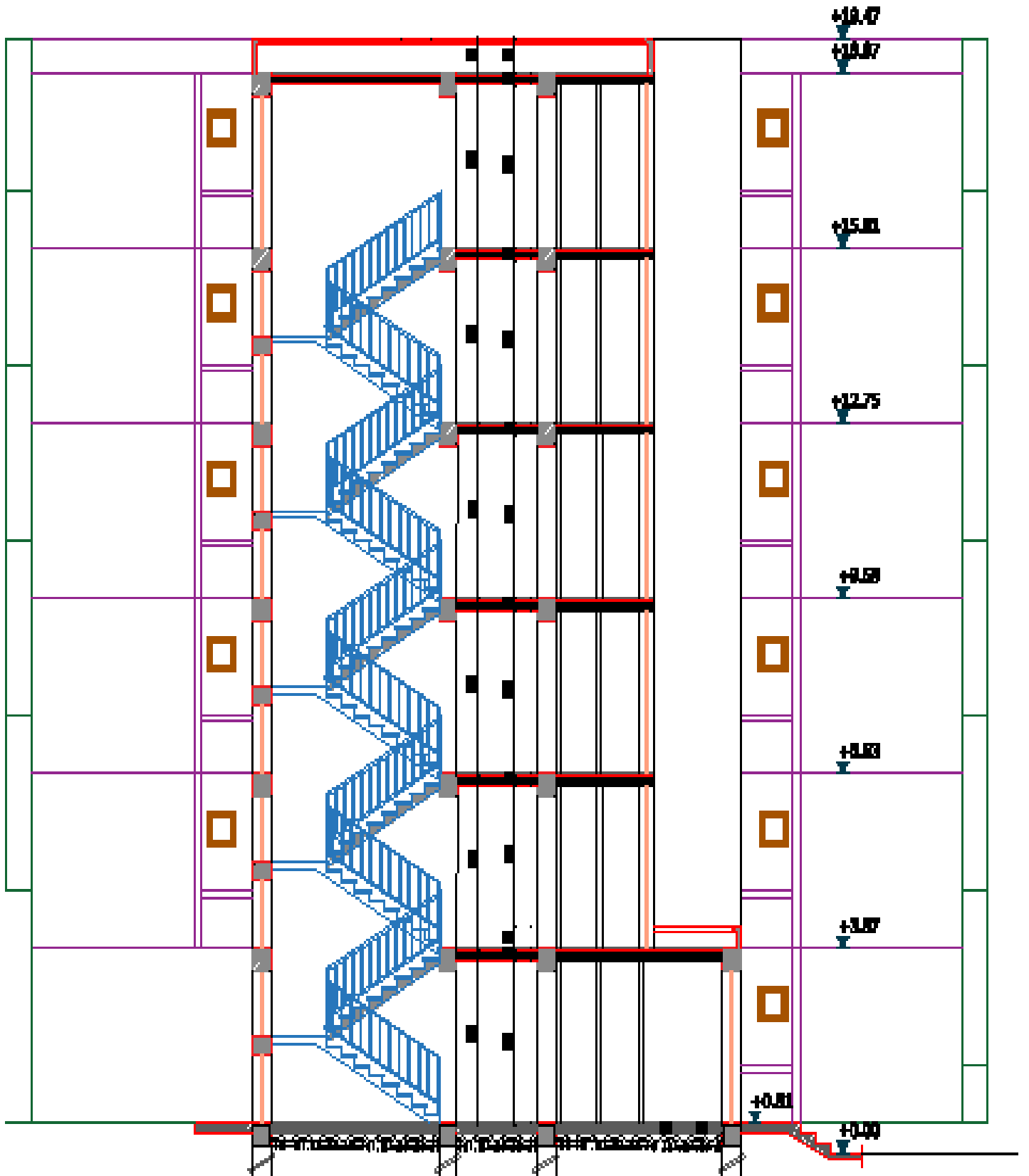

COUPS A-A

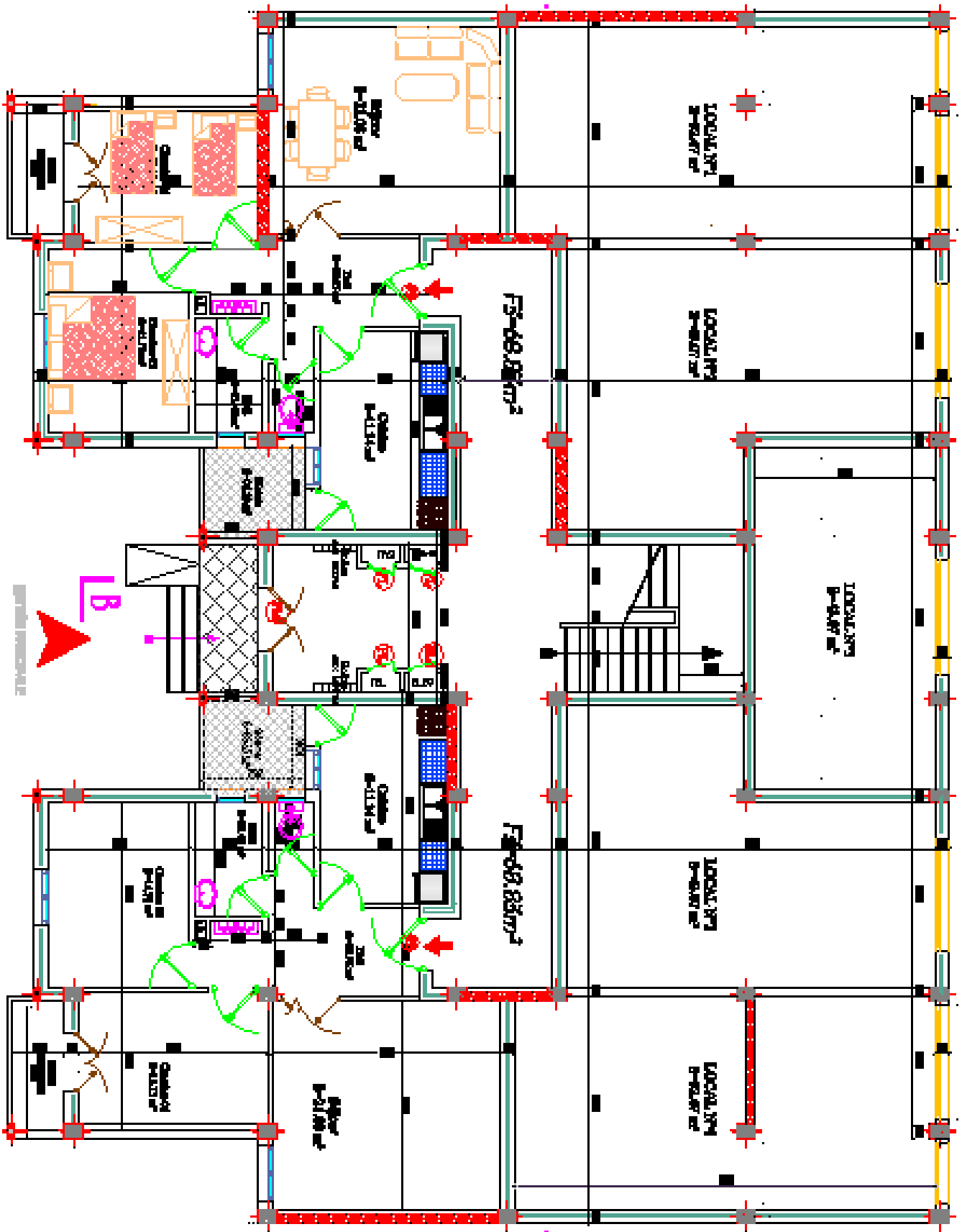

PLAN GROUND FLOOR





PLAN OF GROUND