

See discussions, stats, and author profiles for this publication at: <https://www.researchgate.net/publication/368950857>

Multi-objective Optimal Power Flow and Emission Index Based Firefly Algorithm

Article in *Periodica Polytechnica Electrical Engineering and Computer Science* · March 2023

DOI: 10.3311/PPee.20922

CITATIONS

3

READS

207

1 author:



Nabil Mezhoud

Université 20 août 1955-Skikda

19 PUBLICATIONS 32 CITATIONS

SEE PROFILE

Multi-objective Optimal Power Flow and Emission Index Based Firefly Algorithm

Nabil Mezhoud^{1*}

¹ Electrical Engineering Department, Faculty of Technology, University 20 August 1955 - Skikda, P. O. B. 26, Route El Hadaiek, Skikda 21000, Algeria

* Corresponding author, e-mail: n.mezhoud@univ-skikda.dz

Received: 31 July 2022, Accepted: 19 December 2022, Published online: 01 March 2023

Abstract

The economic operation of electric energy generating systems is one of predominant problems in energy systems. In this work one evolutionary optimization method, based on the meta-inference behavior called the Firefly Algorithm (FFA) is applied to solve such as the multipurpose optimum power flow (OPF) and emission index (EI) problems. Our main goal is to improve the objective function necessary to achieve the best balance between production and its energy consumption, which is presented as a non-linear function, taking into account some constraints of equality and inequality. The goal is to reduce the total cost of generations, active losses, and emission index. The FFA approach was examined and tested on a standard IEEE-30 bus system. The validations of obtained results were compared with some well-known and recently published references. The efficiency and credibility of the proposed method has been proven by the obtained results.

Keywords

emission index, firefly algorithm, power networks, optimal power flow

1 Introduction

Power plants Coal-fired contribute a large quantity of polluting gases to the atmosphere, as they produce large amounts of Carbon oxides CO_2 , and some toxic and dangerous gases such as Sulfur oxides SO_x , and Nitrogen oxides, NO_x [1].

Since Carpenter first discussed the OPF problem in 1962, and then formulated it by Dummel and Tenney in 1968 [2], the OPF problem has a long history in its development of more than 60 years. The major reason of an OPF is to determine the optimal working state of a power system and the equivalent settings for economic operation of control variables [3].

In the past, various deterministic optimization methods have been applied, and some of them are implemented into practice to solve the OPF and EI problems such as Quadratic programming method (QP) [4], Newton and Qassi-newton methods [5, 6], Linear and non-linear programming methods [7–9], and nonlinear internal point methods (IPM) [10].

Several approaches of optimization have been formulated in the last two decades for solving the OPF and EI problems such as Incremental and improved

artificial bee colony (IABC) [11–13], Bacterial foraging algorithms (BFA) [14], Artificial neural networks (ANN) [15], Harmony search (HS) [16], Cuckoo search algorithm (CSA) [17], Evolution programming (EP) [18], Differential evaluation (DE) [19], Genetic algorithms (GA) [20, 21], Gravitational search algorithms (GSA) [22], Particle swarm optimization (PSO) [23], Hybrid PSO GSA [24, 25], Moth Swarm Algorithm (MSA) [26], Wind driven optimization method (WDO) [27], Crow Search Algorithm [28], Teaching-learning-studying-based optimization (TLBO) [29, 30], Firefly Algorithm (FFA) [31], Sine-cosine algorithm (SCA) [32], Modified imperialist competitive algorithm (MICA) [33], Electromagnetism-like mechanism method (ELM) [34], and more recently Grey wolf optimizer (GWO) [35–38].

The key contributions of this paper are as follows:

- This work proposes an already developed FFA algorithm to find the OPF and EI problems.
- An expanded set of variables is used in the suggested OPF formulations.
- To show the efficiency of the proposed method Four single-objective functions such as total generations

cost optimization without and with valve point effect, active power losses optimization, and the gas emission optimization, two bi-objective functions and one of triple objective functions problems are considered in this article considering optimum results of OPF and EI problems.

- The proposed FFA approach is tested and illustrated by numerical examples based on IEEE 30 bus test system.
- Results of the FFA algorithm are compared with simulated results of various and current literature research. So, these compressions prove supremacy of the FFA algorithm in terms of convergence ratio and optimal results based on select OPF and EI problems.
- Analysis statistical showed that FFA algorithm is a robust and reliable optimization method to solve OPF and emission index problems.

2 Problem formulation

The OPF and EI are nonlinear optimization problems, represented by a predefined objective function f , subject to a set of equality and inequality constraints. Generally, the OPF problems can be expressed as follows [39].

$$\text{Min } f(x, u) \quad (1)$$

Subject to

$$h(x, u) = 0 \quad (2)$$

$$g(x, u) \leq 0 \quad (3)$$

$$x_{\min} \leq x \leq x_{\max} \text{ and } u_{\min} \leq u \leq u_{\max}, \quad (4)$$

where $f(x, u)$ is the objective function. The $h(x, u)$ and $g(x, u)$ are, respectively, the equality and inequality constraints. The x and u are the state and control variables respectively. Hence, x can be expressed by Eq. (5):

$$x^t = \{P_{G_1}, |V_{L_1}|, \dots, |V_{L_{n_L}}|, Q_{G_1}, \dots, Q_{G_{n_g}}, S_1, \dots, S_{n_{br}}\}, \quad (5)$$

where P_G , Q_G , V_L and S_K are the generating active power at slack bus, reactive power generated by all generators, magnitude voltage of all load buses and apparent power flow in all branches, respectively. The n_g , n_L and n_{br} are, respectively, the number total of generators, the number total of load buses and the number total of branches. The set control parameters are represented in terms of the decision vector u in Eq. (6):

$$u^t = \{P_{G_2}, \dots, P_{G_{n_g}}, |V_{G_1}|, \dots, |V_{G_{n_g}}|, Q_{1_{com}}, \dots, Q_{n_{com}}, T_1, \dots, T_{n_t}\}, \quad (6)$$

where P_G are the active power generation excluding the slack generator, V_G are the generators magnitudes voltages, T is tap settings transformers, and Q_{com} are the reactive power compensation by shunt compensators, n_{com} and n_t are the number total of compensators and the number total of transformers, respectively.

$$\begin{cases} P_{Gk} = P_k + P_{dk} \\ Q_{Gk} - Q_{comk} = Q_k + Q_{dk} \end{cases} \quad (7)$$

Where P_{Gk} and Q_{Gk} are the scheduled active and reactive power generations at bus k , respectively. P_k , Q_k are the active and reactive power injections at bus k , P_{dk} and Q_{dk} are the active and reactive power loads and the reactive power compensation at bus k . The inequality constraints $g(x, u)$ are represented by the system operational and security limits, listed in Eqs. (8)–(14):

$$P_{gk}^{\min} \leq P_{gk} \leq P_{gk}^{\max} \text{ where } k = 1, \dots, n_g \quad (8)$$

$$Q_{gk}^{\min} \leq Q_{gk} \leq Q_{gk}^{\max} \text{ where } k = 1, \dots, n_g \quad (9)$$

$$V_k^{\min} \leq V_k \leq V_k^{\max} \text{ where } k = 1, \dots, n_b \quad (10)$$

$$\theta_k^{\min} \leq \theta_{gk} \leq \theta_{gk}^{\max} \text{ where } k = 1, \dots, n_b \quad (11)$$

$$T_k^{\min} \leq T_k \leq T_k^{\max} \text{ where } k = 1, \dots, n_T \quad (12)$$

$$Q_{comk}^{\min} \leq Q_{comk} \leq Q_{comk}^{\max} \text{ where } k = 1, \dots, n_{com} \quad (13)$$

$$S_{ki} \leq S_{ki}^{\max} \text{ where } k = 1, \dots, n_b. \quad (14)$$

Where, T , Q_{com} , n_T , n_{com} and S_{ki}^{\max} are the transformers tap settings, the reactive power compensation, the number total of transformers, the number total of compensator and the maximum apparent power between buses k and j .

2.1 Cost optimization

2.1.1 Cost without valve point effect

The cost function of quadratic cost equation for all generators as given in Eq. (15):

$$f_1 = \min \sum_{k=1}^{n_g} C(P_{gk}) = \min \sum_{k=1}^{n_g} a_k + b_k P_{gk} + c_k P_{gk}^2 \quad (15)$$

P_{Gk} and n_G are the active power output generated by the i^{th} generator and the total number of generators. The a_k , b_k and c_k are the coefficients of cost of generator k .

2.1.2 Cost with valve point effect

Typically, when the valve point effect (VPE) is considered, the function is represented in Eq. (16):

$$f_2 = \min \sum_{k=1}^{n_g} [a_k + b_k P_{gk} + c_k P_{gk}^2] + |d_k \sin(e_k (P_{gk}^{\min} - P_{gk}))|, \quad (16)$$

where d_k and e_k are the cost coefficients of unit with valve-point effect.

2.2 Active power loss optimization

The active power loss function f_3 in MW can be expressed by Eq. (17):

$$f_3 = \sum_{k=1}^{n_b} G_{kj} [V_k^2 + V_j^2 - 2V_k V_j \cos \theta_{kj}], \quad (17)$$

where V_k and V_j are the amplitudes voltages at buses k and j , respectively, G_{ki} and θ_{ki} are the conductance of line kj and the angles voltages between buses k and j .

2.3 Gas emission optimization

The emission function is the sum of exponential and quadratic functions of real power generating. Using a quadratic equation, emission is calculated in ton/h as given in Eq. (18):

$$f_4 = \min \sum_{k=1}^{n_g} 10^{-2} (\alpha_k + \beta_k P_{gk} + \gamma_k P_{gk}^2) + \zeta_k \exp(\lambda_k P_{gk}), \quad (18)$$

where f_4 is the emission function in ton/h, $\alpha_k, \beta_k, \gamma_k, \zeta_k$ and λ_k are the coefficients of emission of the generator k .

3 Firefly algorithm

The Firefly Algorithm (FFA) is a meta-heuristic algorithm was inspired by the flashing light of fireflies and developed by Xin-She Yang [40]. All the fireflies are considered unisexual, and their attraction is directly proportional to the intensity of their flash. Therefore, if a firefly particle had the choice of moving toward either of two fireflies, it will be more attracted toward the firefly with higher brightness and moves in that direction. If there are no fireflies nearby, the firefly will move in a random direction [41, 42].

A firefly is set of control variables of the problem considered. Brightness of the firefly is calculated by evaluating the objective function to be optimized [43]. The brightness of flash is associated with the fitness function. As a firefly's attractiveness is proportional to the light intensity seen by adjacent fireflies, the attractiveness β of a firefly can be defined as a function of the Cartesian distance r between the fireflies [43–46]:

$$\beta = \beta_0 \exp(-\gamma r^2), \quad (19)$$

where β_0 is the attractiveness at $r = 0$ and the absorption coefficient γ is taken as 0.9. The movement of a firefly i is

attracted to another more attractive (brighter) firefly j is determined by Eq. (20):

$$X_i^{(t+1)} = X_i^t + \beta_0 \exp(-\gamma r_{ij}^2) (X_j^t - X_i^t) + \alpha \epsilon. \quad (20)$$

The randomization coefficient α is ranges from 0 to 1 and ϵ is the vector of random numbers taken from Gaussian distribution ranges from 0 to 0.5 [47]. At the end of all generations, the firefly with the highest brightness, i.e., the best fitness value is concluded as the optimal solution to the problem [48]. The Cartesian distance is used to calculate the distance between fireflies i and j as given in Eq. (21) [49–51].

$$r_{ij} = \|X_i - X_j\| = \sqrt{\sum_{k=1}^d (X_i^k - X_j^k)^2} \quad (21)$$

Fireflies moves randomly and try to attract towards brighter firefly. FFA improves problems solution iteration by iteration and the iteration has to be stopped either the problem is converged, or iteration reached its maximum value. Stopping of iteration is important to provide solution for time complexity.

4 Results and discussion

The five generators system, IEEE-30 bus is used during this work. This system consists, 30 buses, 6 generators units and 41 branches, 37 of them are the transmissions lines and 4 are the tap changing transformers. The bus 1 is chosen like as a slack bus, the buses containing generators are taken the PV buses, the remaining buses are the PQ buses or loads buses. It is assumed that 9 capacitors compensation is available at buses 10, 12, 15, 17, 20, 21, 23, 24 and 29. The network data, the coefficients of cost and emission of five generators are referred in [52]. The single line diagram test system IEEE 30 bus is shown in Fig. 1. The total loads

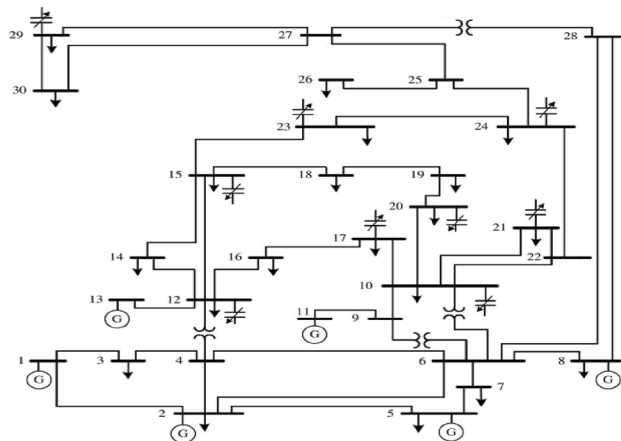

Fig. 1 Single line diagram of IEEE-30 bus system

of active and reactive powers are, respectively, 283.4 MW and 126.2 MVar, with 24 control variables. The basis apparent power used in this paper is 100 MVA.

The simulation results of load flow problem are summarized in Table 1. In this work, the minimum and maximum magnitudes voltages are, respectively, set to 0.95 and 1.1. The attractiveness and Randomizing coefficients are taken as 0.9 and 0.4, respectively.

4.1 Case 1: Cost optimization

4.1.1 Cost without valve point effect

In this case, the cost is resulted in 802.49 \$/h, which is 5.918% less than the initial case (load flow).

Table 1 Single objective results of test system

Control variables	Basis	Optimal values		
		Case 1		Case 2
		w/o valve	with valve	
P_{G2} (MW)	40.000	48.467	25.821	44.481
P_{G5} (MW)	0.000	21.482	15.285	50.000
P_{G8} (MW)	0.000	22.901	11.790	34.802
P_{G11} (MW)	0.000	12.427	17.513	21.263
P_{G13} (MW)	0.000	12.041	12.000	39.997
V_1 (pu)	1.060	1.071	1.071	1.004
V_2 (pu)	1.045	1.051	1.044	0.993
V_5 (pu)	1.050	1.011	1.009	0.969
V_8 (pu)	1.070	1.019	1.001	0.975
V_{11} (pu)	1.090	1.030	0.993	1.029
V_{13} (pu)	1.090	1.054	1.053	1.031
Q_{com10} (MVar)	0.000	4.674	2.680	0.767
Q_{com12} (MVar)	0.000	0.432	4.428	1.123
Q_{com15} (MVar)	0.000	3.133	4.133	2.304
Q_{com17} (MVar)	0.000	0.043	3.114	0.454
Q_{com20} (MVar)	0.000	1.656	2.725	2.944
Q_{com21} (MVar)	0.000	3.127	1.047	1.952
Q_{com23} (MVar)	0.000	0.047	0.054	1.904
Q_{com24} (MVar)	0.000	1.746	4.039	4.647
Q_{com29} (MVar)	0.000	2.729	1.825	3.123
T_{6-9}	0.978	0.923	1.003	1.030
T_{6-10}	0.969	0.930	0.952	0.926
T_{4-12}	0.966	1.079	0.916	0.923
T_{27-28}	0.9320	0.9895	0.945	0.973
Cost (\$/h)	874.22	802.49	951.8	907.87
Losses (MW)	17.560	9.432	12.094	4.723
Emission (ton/h)	4.100	-	-	-
Slack (MW)	260.96	175.51	213.08	97.57
CPU time (s)	19.820	78.67	93.99	81.94

4.1.2 Cost with valve point effect

In this case, the cost is resulted in 835.57 \$/h, which is careful 4.421% less than the initial case. The convergence algorithm of case 1 is introduced in Fig. 2. The optimal control variables of case 1 are presented summarizes in Table 1.

4.2 Case 2: Active power loss optimization

The control variables of case 2 are introduced in Table 1. Fig. 3 shows the trend for convergence characteristics of active losses. The power loss is significantly reduced in 4.723 MW which is 73.103% less than the initial case.

4.3 Case 3: Gas emission optimization

In this case, the emission reduction yielded 0.218 ton/h which is 98.747% less than the initial case. The optimal control variables for case 3 are detailed in Table 2. Fig. 4 shows the convergence algorithm of emission obtained in case 3.

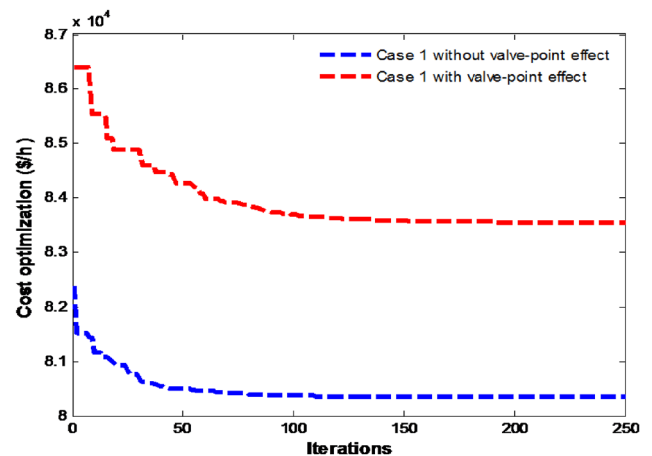

Fig. 2 Convergences of algorithm for case 1

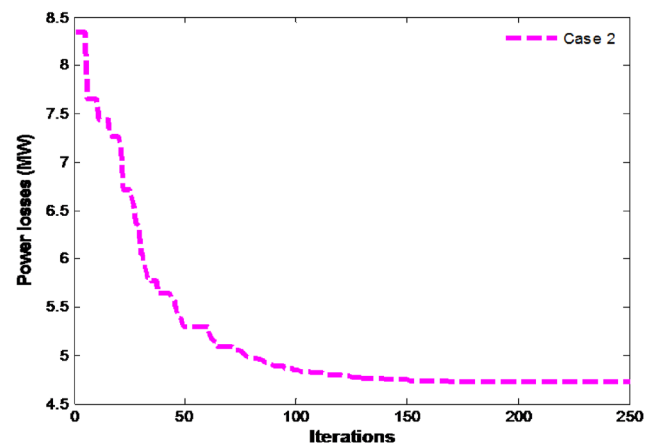

Fig. 3 Convergences of algorithm for case 2

Table 2 Results of cases 3 and 4

Control variables	Optimal values		
	Case 3	Case 4	
		w/o valve	with valve
P_{G2} (MW)	71.475	55.219	69.186
P_{G5} (MW)	46.922	32.335	29.976
P_{G8} (MW)	34.054	30.103	17.552
P_{G11} (MW)	24.683	21.129	17.088
P_{G13} (MW)	33.415	19.273	21.805
V_1 (pu)	1.022	1.062	1.0752
V_2 (pu)	1.011	1.048	1.060
V_5 (pu)	1.032	1.019	1.027
V_8 (pu)	0.973	1.029	1.038
V_{11} (pu)	0.999	1.051	0.996
V_{13} (pu)	1.070	1.071	1.080
Q_{com10} (MVar)	0.316	0.886	4.525
Q_{com12} (MVar)	1.251	3.873	0.008
Q_{com15} (MVar)	2.316	3.994	1.054
Q_{com17} (MVar)	2.070	0.541	0.154
Q_{com20} (MVar)	4.628	0.764	4.439
Q_{com21} (MVar)	3.480	4.864	4.388
Q_{com23} (MVar)	3.096	2.650	0.035
Q_{com24} (MVar)	2.884	3.043	0.268
Q_{com29} (MVar)	4.583	0.928	0.525
T_{6-9}	1.068	1.000	1.029
T_{6-10}	0.918	0.934	0.936
T_{4-12}	0.984	0.997	1.026
T_{27-28}	0.917	0.958	0.987
Cost (\$/h)	0.220	822.930	824.53
Losses (MW)	5.3674	6.279	7.1175
Emission (ton/h)	0.2189	-	-
Slack (MW)	78.215	-	-
CPU time (s)	86.859	131.618	134.908

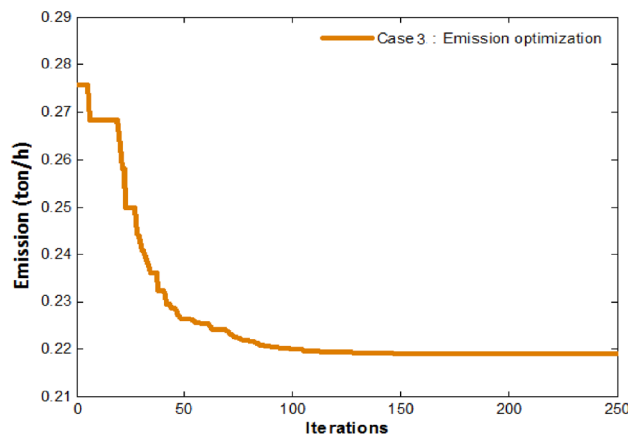

Fig. 4 Convergence of algorithm for case 3

4.4 Case 4: Cost and active loss optimization

The control variables of case 4 are clarifier detailed in Table 2. The cost has resulted in 822.23 \$/h and 824.53 \$/h without and with VPE, respectively, which is 5.947% and 5.684% less than the initial case. The power losses are reduced in 6.279 MW and 7.117 MW without and with VPE, respectively, which is careful 64.242% and 59.47% less than the initial case. The convergence algorithm of case 4 is shown in Fig. 5.

4.5. Case 5: Cost and gas emission optimization

The control variables of case 5 are presented in detail in Table 3. The cost has resulted in 801.59 \$/h and 837.97 \$/h, without and with VPE, respectively, which is 8.312% and 4.147% inferior to the initial case. The emission is reduced in 0.312 ton/h and 0.448 ton/h without and with VPE, respectively, which is careful 92.39% and 89.073% less than the initial case. Fig. 6 shows the convergence of case 5.

4.6. Case 6: Cost, active loss and gas emission

The control variables of case 6 are presented in detail in Table 3. The costs are resulted in 826.49 \$/h and 862.29 \$/h without and with VPE, respectively, which is considered 8.312% and 4.147% lower than the initial case. The power losses are reduced in 6.159 MW and 7.117 MW without and with VPE, respectively, which is careful 8.312% and 4.147% lower than the initial case. The emission is reduced in 0.206 ton/h and 0.254 ton/h without and with VPE, respectively, which is careful 93.804% and 94.975% lower than the initial case. The convergence algorithm of case 6 is shown in Fig. 7.

For the test system, IEEE 30 bus, there are 24 control variables (5 generators excluding slack bus, 6 generators

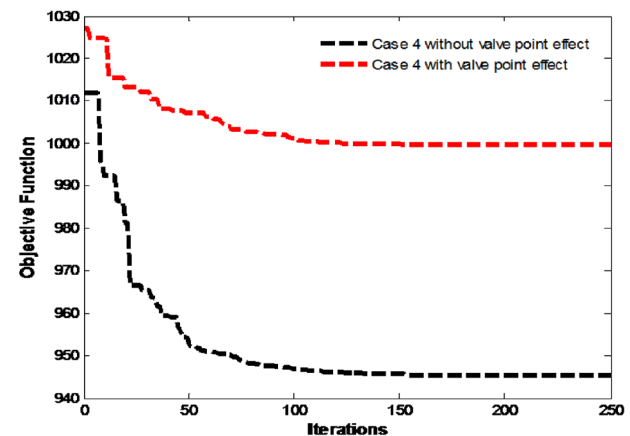

Fig. 5 Convergence of algorithm for case 4

Table 3 Multi-objective results of test system

Control variables	Optimal values			
	Case 5		Case 6	
	w/o valve	w/ valve	w/o valve	w/ valve
P_{G2} (MW)	48.476	41.679	51.311	48.360
P_{G5} (MW)	21.156	17.980	30.525	29.251
P_{G8} (MW)	19.541	18.115	35.000	34.156
P_{G11} (MW)	12.815	11.818	21.348	24.549
P_{G13} (MW)	12.636	12.000	24.170	18.250
V_1 (pu)	1.088	1.100	1.067	1.088
V_2 (pu)	1.066	1.082	1.053	1.073
V_5 (pu)	1.029	1.064	1.023	1.048
V_8 (pu)	1.036	1.047	1.036	1.056
V_{11} (pu)	1.066	1.082	0.986	1.068
V_{13} (pu)	1.033	1.057	1.039	1.034
Q_{com10} (MVar)	2.540	3.341	1.718	2.799
Q_{com12} (MVar)	0.914	0.175	1.000	2.997
Q_{com15} (MVar)	4.814	0.018	0.478	1.119
Q_{com17} (MVar)	4.006	0.178	3.543	1.005
Q_{com20} (MVar)	1.633	1.984	1.030	4.527
Q_{com21} (MVar)	1.957	2.180	0.386	3.868
Q_{com23} (MVar)	0.801	4.171	2.456	3.127
Q_{com24} (MVar)	2.848	4.238	1.033	3.480
Q_{com29} (MVar)	0.024	4.713	4.315	4.949
T_{6-9}	1.018	0.927	0.963	1.047
T_{6-10}	0.929	0.947	1.054	0.985
T_{4-12}	0.976	0.939	1.077	0.992
T_{27-28}	0.927	0.982	0.998	1.001
Objective function	801.59	837.97	946.59	980.75
Cost (\$/h)	801.59	837.97	826.49	862.29
loss (MW)	9.292	11.339	6.159	6.073
Emission (ton/h)	0.312	0.448	0.206	0.254
Slack (MW)	173.28	191.86	127.20	134.90
CPU time (s)	80.72	107.28	80.46	87.66

magnitude voltages, 4 transformers taps and 9 reactive powers compensators) were optimized.

Tables 4, 5 and 6 show a comparison between the obtained and literature results for cases 3, 4, 5 and 6.

5 Conclusions

In this paper, the FFA approach is implemented and applied successfully for solving the multi-objective optimal power

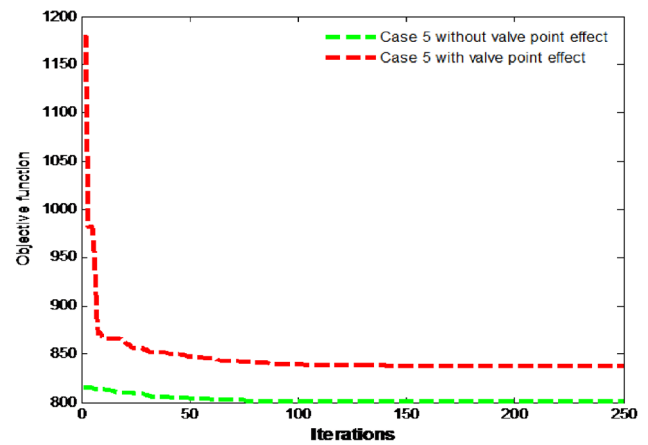

Fig. 6 Convergence of algorithm for case 5

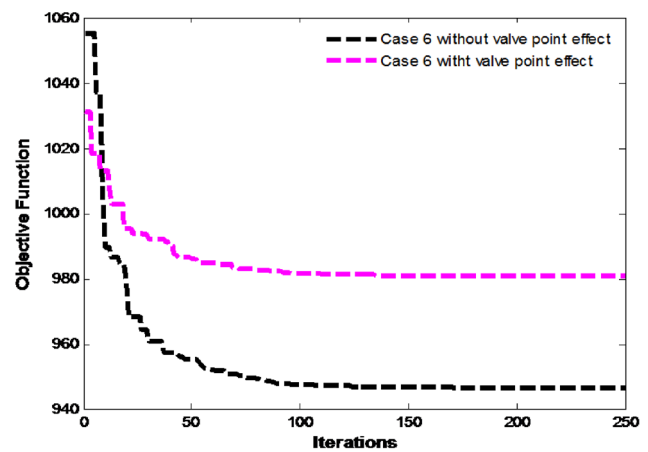

Fig. 7 Convergence of algorithm for case 6

flow. In terms of solution excellence, this algorithm is highly efficient in dealing with the multimodal global optimization problems and the comparison results confirm the advantage of the proposed approach over some of other methods used to solve the optimal power flow. Thus, the FFA may be recommended as a promising approach for solving some more complex engineering problems.

The versatility of optimization is illustrated by different tests systems by changing the parameters of FFA approach such as number of population size, randomization parameter and absorption coefficient. The robustness of proposed FFA algorithm is examined in terms of best, average, and worse function. The results of simulation demonstrated the efficiency and robustness of proposed method.

Table 4 Comparison of obtained results for cases 3 and 4

Methods	Ref.	Cost (\$/h)	Losses (MW)	Emission (ton/h)
Case 3				
Proposed	-	954.3807	5.1640	0.2189
GA	[35]	936.6200	9.7000	0.2117
MSA	[26]	944.5003	3.2858	0.2048
MPSO	[26]	879.9464	7.0467	0.2324
PSGWO	[33]	944.5120	3.2358	0.2048
MDE	[26]	927.8066	4.8539	0.2092
MFO	[26]	945.4553	3.4295	0.2048
FPA	[26]	948.9490	4.4920	0.2052
ABC	[12]	944.4391	3.2470	0.2048
IABC	[13]	-	-	0.1943
MOGWO	[25]	945.3785	3.5519	0.2049
CSA	[28]	950.9308	3.5708	0.2010
Case 4				
Proposed	-	822.93	6.279	-
MSA	[26]	859.191	4.540	-
PSO	[23]	878.873	7.810	-
DE	[21]	828.5900	5.6900	-
MICA	[33]	848.054	4.560	-
GWO	[35]	820.850	6.130	-
EGA	[21]	822.8700	5.6130	-
TLBO	[30]	828.5300	5.2883	-
IABC	[12]	854.9136	4.9820	0.2280
MPSO	[25]	859.5841	4.5409	0.2287
PSOGSA	[24]	822.4063	5.4681	-
MDE	[26]	868.7138	4.3891	0.2252
MFO	[26]	858.5812	4.5772	0.2294
FPA	[26]	855.2706	4.7981	0.2295
MOGW	[36]	847.9695	4.5886	0.2229

Table 5 Comparison of obtained results for case 5

Methods	Ref.	Cost (\$/h)	Losses (MW)	Emission (ton/h)
Case 5				
Proposed	-	801.590	9.292	0.312
GA	[20]	820.166	-	0.271
MICA	[33]	865.066	-	0.222
ABC	[24]	820.1666	6.7244	0.2712
PSO	[23]	822.0920	-	0.2680
MOGWO	[35]	866.9852	5.3740	0.2229

Table 6 Comparison of obtained results for case 6

Methods	Ref.	Cost (\$/h)	Losses (MW)	Emission (ton/h)
Case 6				
Proposed	-	826.490	6.159	0.227
GA	[20]	793.605	8.450	0.187
IABC	[12]	851.611	4.873	0.223
ABC	[12]	854.916	4.982	0.228
DE	[19]	867.980	5.563	0.266

References

[1] Talaq, J. H., El-Hawary, F., El-Hawary, M. E. "A Summary of Environmental/Economic Dispatch Algorithms", IEEE Transactions on Power Systems, 9(3), pp. 1508–1516, 1994. <https://doi.org/10.1109/59.336110>

[2] Dommel, H. W., Tinney, W. F. "Optimal Power Flow Solutions", IEEE Transactions on Power Apparatus and Systems, PAS-87(10), pp. 1866–1876, 1968. <https://doi.org/10.1109/TPAS.1968.292150>

[3] Lai, L. L., Ma, J. T., Yokoyama, R., Zhao, M. "Improved Genetic Algorithms for Optimal Power Flow under both Normal Contingent Operation States", International Journal of Electrical Power & Energy Systems, 19(5), pp. 287–292, 1997. [https://doi.org/10.1016/s0142-0615\(96\)00051-8](https://doi.org/10.1016/s0142-0615(96)00051-8)

[4] Nicholson, H., Sterling, M. J. H. "Optimum Dispatch of Active and Reactive Generation by Quadratic Programming", IEEE Transactions on Power Apparatus and Systems, PAS-92(2), pp. 644–654, 1973. <https://doi.org/10.1109/TPAS.1973.293768>

[5] Santos Jr., A., da Costa, G. R. M. "Optimal-Power-Flow Solution by Newton's Method Applied to an Augmented Lagrangian Function", IEE Proceedings - Generation, Transmission and Distribution, 142(1), pp. 33–36, 1995. <https://doi.org/10.1049/ip-gtd:19951586>

[6] Giras, T. C., Talukdar, S. N. "Quasi-Newton Method for Optimal Power Flows", International Journal of Electrical Power & Energy Systems, 3(2), pp. 59–64, 1981. [https://doi.org/10.1016/0142-0615\(81\)90010-7](https://doi.org/10.1016/0142-0615(81)90010-7)

[7] Stott, B., Hobson, E. "Power System Security Control Calculations Using Linear Programming, Part I", IEEE Transactions on Power Apparatus and Systems, PAS-97(5), pp. 1713–1720, 1978. <https://doi.org/10.1109/TPAS.1978.354664>

[8] Stott, B., Hobson, E. "Power System Security Control Calculations Using Linear Programming, Part II", IEEE Transactions on Power Apparatus and Systems, PAS-97(5), pp. 1721–1731, 1978. <https://doi.org/10.1109/TPAS.1978.354665>

- [9] Sasson, A. M. "Nonlinear Programming Solutions for Load-Flow, Minimum-Loss, and Economic Dispatching Problems", *IEEE Transactions on Power Apparatus and Systems*, PAS-88(4), pp. 399–409, 1969.
<https://doi.org/10.1109/TPAS.1969.292460>
- [10] Capitanescu, F., Glavic, M., Ernst, D., Wehenkel, L. "Interior-point Based Algorithms for the Solution of Optimal Power Flow Problems", *Electric Power Systems Research*, 77(5–6), pp. 508–517, 2007.
<https://doi.org/10.1016/j.epsr.2006.05.003>
- [11] Aydın, D., Özyön, S. "Solution to Non-convex Economic Dispatch Problem with Valve Point Effects by Incremental Artificial Bee Colony with Local Search", *Applied Soft Computing*, 13(5), pp. 2456–2466, 2013.
<http://doi.org/10.1016/j.asoc.2012.12.002>
- [12] He, X., Wang, W., Jiang, J., Xu, L. "An Improved Artificial Bee Colony Algorithm and Its Application to Multi-Objective Optimal Power Flow", *Energies*, 8(4), pp. 2412–2437, 2015.
<https://doi.org/10.3390/en8042412>
- [13] Rezaei Adaryani, M., Karami, A. "Artificial Bee Colony Algorithm for Solving Multi-objective Optimal Power Flow Problem", *International Journal of Electrical Power & Energy Systems*, 53, pp. 219–223, 2013.
<https://doi.org/10.1016/j.ijepes.2013.04.021>
- [14] Zakaria, Z., Rahman, T. K. A., Hassan, E. E. "Economic Load Dispatch via an Improved Bacterial Foraging Optimization", In: 2014 IEEE 8th International Power Engineering and Optimization Conference (PEOCO2014), Langkawi, Malaysia, 2014, pp. 380–385. ISBN 978-1-4799-2422-6
<https://doi.org/10.1109/PEOCO.2014.6814458>
- [15] Kirschen, D., Hookings, A., Kemhadjian, H., Kemhadjian, H., Ghassemlooy, Z., Gibson, A. "Book Reviews: Intelligent System Applications in Power Engineering: Evolutionary Programming and Neural Networks, Mathematical Modeling for Industry and Engineering, Microlithography: Science and Technology, Microlithography Fundamentals in Semiconductor Devices and Fabrication Technology, Introduction to Digital Mobile Communication, Theory of Nonuniform Waveguides: The Cross-Section Method", *The International Journal of Electrical Engineering & Education*, 36(3), pp. 274–278, 1999.
<https://doi.org/10.7227/IJEEE.36.3.9>
- [16] Khazali, A. H., Kalantar, M. "Optimal Reactive Power Dispatch Based on Harmony Search Algorithm", *International Journal of Electrical Power & Energy Systems*, 33(3), pp. 684–692, 2011.
<https://doi.org/10.1016/j.ijepes.2010.11.018>
- [17] Abd-Elazim, S. M., Ali, E. S. "Optimal Power System Stabilizers design via Cuckoo Search algorithm", *International Journal of Electrical Power & Energy Systems*, 75, pp. 99–107, 2016.
<https://doi.org/10.1016/j.ijepes.2015.08.018>
- [18] Yuryevich, J., Wong, K. P. "Evolutionary Programming based Optimal Power Flow Algorithm", *IEEE Transactions on Power Systems*, 14(4), pp. 1245–1250, 1999.
<https://doi.org/10.1109/59.801880>
- [19] Abou El Ela, A. A., Abido, M. A., Spea, S. R. "Optimal Power Flow using Differential Evolution Algorithm", *Electric Power Systems Research*, 80(7), pp. 878–885, 2010.
<https://doi.org/10.1016/J.EPSR.2009.12.018>
- [20] Yaşar, C., Özyön, S. "A New Hybrid Approach for Nonconvex Economic Dispatch Problem with Valve-Point Effect", *Energy*, 36(10), pp. 5838–5845, 2011.
<https://doi.org/10.1016/j.energy.2011.08.041>
- [21] Kumari, M. S., Maheswarapu, S. "Enhanced Genetic Algorithm Based Computation Technique for Multi-objective Optimal Power Flow Solution", *International Journal of Electrical Power & Energy Systems*, 32(6), pp. 736–742, 2010.
<https://doi.org/10.1016/j.ijepes.2010.01.010>
- [22] Bhowmik, A. R., Chakraborty, A. K. "Solution of Optimal Power Flow Using Nondominated Sorting Multi Objective Gravitational Search Algorithm", *International Journal of Electrical Power & Energy Systems*, 62, pp. 323–334, 2014.
<https://doi.org/10.1016/j.ijepes.2014.04.053>
- [23] Abido, M. A. "Optimal Power Flow Using Particle Swarm Optimization", *International Journal of Electrical Power & Energy Systems*, 24(7), pp. 563–571, 2002.
[https://doi.org/10.1016/S0142-0615\(01\)00067-9](https://doi.org/10.1016/S0142-0615(01)00067-9)
- [24] Mishra, S. K., Mishra, S. K. "A Comparative Study of Solution of Economic Load Dispatch Problem in Power Systems in the Environmental Perspective", *Procedia Computer Science*, 48, pp. 96–100, 2015.
<https://doi.org/10.1016/j.procs.2015.04.156>
- [25] Edwin Selva Rex, C. R., Beno, M. M., Annrose, J. "Optimal Power Flow-Based Combined Economic and Emission Dispatch Problem Using Hybrid PSGWO Algorithm", *Journal of Circuits, Systems, and Computers*, 28(9), 1950154, 2019.
<https://doi.org/10.1142/S0218126619501548>
- [26] Mohamed, A.-A. A., Mohamed, Y. S., El-Gaafary, A. A. M., Hemeida, A. M. "Optimal Power Flow Using Moth Swarm Algorithm", *Electric Power Systems Research*, 142, pp. 190–206, 2017.
<https://doi.org/10.1016/j.epsr.2016.09.025>
- [27] Mezhoud, N., Ayachi, B., Bahri, A. "Wind Driven Optimization Approach based Multi-objective Optimal Power Flow and Emission Index Optimization", *International Research Journal of Multidisciplinary Technovation*, 4(2), pp. 21–41, 2022.
<https://doi.org/10.54392/irjmt2223>
- [28] Fathy, A., Abdelaziz, A. "Single-objective Optimal Power Flow for Electric Power Systems Based on Crow Search Algorithm", *Archives of Electrical Engineering*, 67(1), pp. 123–138, 2018.
<https://doi.org/10.24425/118996>
- [29] Akbari, E., Ghasemi, M., Gil, M., Rahimnejad, A., Andrew Gadsden, S. "Optimal Power Flow via Teaching-Learning-Studying-Based Optimization Algorithm", *Electric Power Components and Systems*, 49(6–7), pp. 584–601, 2021.
<https://doi.org/10.1080/15325008.2021.1971331>
- [30] Mandal, B., Kumar Roy, P. "Multi-objective Optimal Power Flow Using Quasi-oppositional Teaching Learning Based Optimization", *Applied Soft Computing*, 21, pp. 590–606, 2014.
<https://doi.org/10.1016/j.asoc.2014.04.010>

- [31] Padaiyatchi, S. S. "Hybrid DE/FFA Algorithm Applied for Different Optimal Reactive Power Dispatch Problems", *Australian Journal of Electrical and Electronics Engineering*, 17(3), pp. 203–210, 2020.
<https://doi.org/10.1080/1448837X.2020.1817233>
- [32] Attia, A.-F., El Sehiemy, R. A., Hasanien, H. M. "Optimal Power Flow solution in Power Systems using a Novel Sine-Cosine Algorithm", *International Journal of Electrical Power & Energy Systems*, 99, pp. 331–343, 2018.
<https://doi.org/10.1016/j.ijepes.2018.01.024>
- [33] Ghasemi, M., Ghavidel, S., Ghanbarian, M. M., Gharibzadeh, M., Azizi Vahed, A. "Multi-objective Optimal Power Flow Considering the Cost, Emission, Voltage Deviation and Power Losses using Multi-Objective Modified Imperialist Competitive Algorithm", *Energy*, 78, pp. 276–289, 2014.
<https://doi.org/10.1016/j.energy.2014.10.007>
- [34] El-Hana Bouchekara, H. R., Abido, M. A., Chaib, A. E. "Optimal Power Flow Using an Improved Electromagnetism-like Mechanism Method", *Electric Power Components and Systems*, 44(4), pp. 434–449, 2016.
<https://doi.org/10.1080/15325008.2015.1115919>
- [35] Pradhan, M., Roy, P. K., Pal, T. "Grey Wolf Optimization Applied to Economic Load Dispatch Problems", *International Journal of Electrical Power & Energy System*, 83, pp. 325–334, 2016.
<https://doi.org/10.1016/j.ijepes.2016.04.034>
- [36] El-Fergany, A. A., Hasanien, H. M. "Single and Multi-objective Optimal Power Flow Using Grey Wolf Optimizer and Differential Evolution Algorithms", *Electric Power Components and Systems*, 43(13), pp. 1548–1559, 2015.
<https://doi.org/10.1080/15325008.2015.1041625>
- [37] Mohamed, A.-A. A., El-Gaafary, A. A. M., Mohamed, Y. S., Hemeida, A. M. "Multi-Objective Modified Grey Wolf Optimizer for Optimal Power Flow", In: 2016 Eighteenth International Middle East Power Systems Conference (MEPCON), Cairo, Egypt, 2016, pp. 982–990. ISBN 978-1-4673-9064-4
<https://doi.org/10.1109/MEPCON.2016.7837016>
- [38] Dilip, L., Bhesdadiya, R., Trivedi, I., Jangir, P. "Optimal Power Flow Problem Solution using Multi-objective Grey Wolf Optimizer Algorithm", In: Hu, Y. C., Tiwari, S., Mishra, K., Trivedi, M. (eds.) *Intelligent Communication and Computational Technologies*, Springer, 2018, pp. 191–201. ISBN 978-981-10-5522-5
https://doi.org/10.1007/978-981-10-5523-2_18
- [39] Mezhoud, N., Leulmi, S., Boukadoum, A. "AC-DC Optimal Power Flow Incorporating Shunt FACTS Devices Using HVDC Model and Particle Swarm Optimization Method", *International Review of Electrical Engineering (IREE)*, 9(2), pp. 382–392, 2014.
- [40] Yang, X.-S. "Firefly Algorithms for Multimodal Optimization", In: Watanabe, O., Zeugmann, T. (eds.) *Stochastic Algorithms: Foundations and Applications*, Springer, 2009, pp. 169–178, 2009. ISBN 978-3-642-04943-9
https://doi.org/10.1007/978-3-642-04944-6_14
- [41] Radosavljević, J. "Metaheuristic Optimization in Power Engineering", *The Institution of Engineering and Technology*, 2018. ISBN 978-1-78561-546-7
<https://doi.org/10.1049/PBPO131E>
- [42] Balachennaiah, P., Suryakalavathi, M., Nagendra, P. "Firefly Algorithms based Solution to Minimize the Real Power Loss in a Power System", *Ain Shams Engineering Journal*, 9(1), pp. 89–100, 2018.
<https://doi.org/10.1016/j.asej.2015.10.005>
- [43] Ravi, C. N., Reddy, D. B. G. "Optimal Power Flow Solutions Using Firefly Algorithm", [pdf] *International Journal of Current Engineering and Scientific Research*, 5(4), pp. 240–246, 2018. Available at: <http://troindia.in/journal/ijcesr/vol5iss4/240-246.pdf> [Accessed: 19 November 2021]
- [44] Lastomo, D., Widodo, Setiadi, H. "Optimal Power Flow using Fuzzy-Firefly Algorithm", In: 2018 5th International Conference on Electrical Engineering, Computer Science and Informatics (EECSI), Malang, Indonesia, 2018, pp. 210–215. ISBN 978-1-5386-8403-0
<https://doi.org/10.1109/EECSI.2018.8752903>
- [45] Herbadji, O., Bouktir, T. "Optimal Power Flow Using Firefly Algorithm with Consideration of FACTS Devices "UPFC"", *International Journal on Electrical Engineering and Informatics*, 7(1), pp. 12–28, 2015.
<https://doi.org/10.15676/ijeei.2015.7.1.2>
- [46] Lenin, K. "Active Power Loss Reduction by Firefly Algorithm", *International Journal of Research - Granthaalayah*, 6(3), pp. 155–165, 2018.
<https://doi.org/10.29121/granthaalayah.v6.i3.2018.1509>
- [47] Sugirtha, M. G., Latha, P. "Firefly Algorithm Based Multi-Objective Optimal Power Flow in the Presence of Wind Power", *Asian Journal of Information Technology*, 15(4), pp. 703–711, 2016.
<https://doi.org/10.36478/ajit.2016.703.711>
- [48] Jun, C. S., Abd Halim, S., Rosli, H. M., Kamari, N. A. M. "Power Loss Minimization using Optimal Power Flow based on Firefly Algorithm", *International Journal of Advanced Computer Science and Applications (IJACSA)*, 12(9), pp. 358–364, 2021.
<https://doi.org/10.14569/IJACSA.2021.0120940>
- [49] Karboune, K., Chaib, I., Arif, S., Choucha, A. "Optimal Power Flow Using firefly-algorithm", *International Journal of Development*, 10(1), pp. 41–49, 2021.
<https://doi.org/10.21608/IDJ.2021.216606>
- [50] Khan, A., Hizam, H., Abdul-Wahab, N. I., Othman, M. L. "Solution of Optimal Power Flow Using Non-Dominated Sorting Multi Objective Based Hybrid Firefly and Particle Swarm Optimization Algorithm", *Energies*, 13(16), 4265, 2020.
<https://doi.org/10.3390/en13164265>
- [51] Govindaraj, T., Tamildurai, V. "Firefly Algorithm for Optimal Power Flow Considering Control Variables", *International Journal of Innovative Research in Electrical, Electronics, Instrumentation and Control Engineering*, 2(2), pp. 1116–1121, 2014.
- [52] Lee, K. Y., El-Sharkawi, M. A. "Modern Heuristic Optimization Techniques: Theory and Applications to Power Systems", John Wiley & Sons, 2008. ISBN 9780471457114
<https://doi.org/10.1002/9780470225868>